

Press Pac[®] 2100[®]

PRESS PAC[®] 2100 SERIES
HYDRAULIC ACTUATION / OIL COOLED PRESS DRIVES

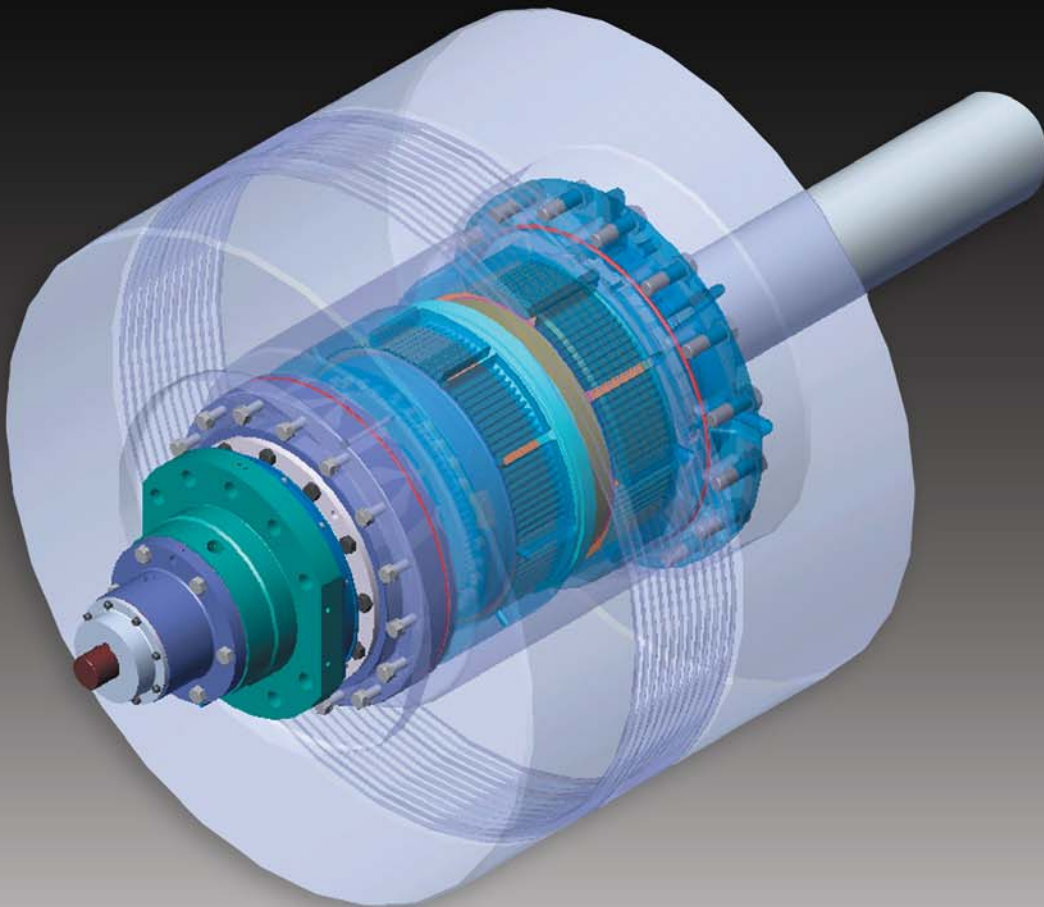

High Performance Press Drives For Metal Forming Presses



Press Pac® 2100 Series Integral Press Drive Systems

The original Press Pac® Oil Shear Press Drives were introduced in 1968. Since that time, our press drive systems are proven in the toughest of applications where reliability and performance of these systems are necessary to meet today's production requirements.

Since 1968, Midwest Brake has converted thousands of geared stamping presses to the Press Pac® drive system. Most presses are simply and easily converted to Press Pac® with only minor modification to the existing press parts.

Superior performance and ease of installation make the Press Pac® 2100 Series the preferred press drive for the metal forming industry, automotive stamping and contract stamping facilities world wide. Press Pac® 2100 Series will increase machine uptime and reliability, provide reduced maintenance requirements and will decrease repair costs over the life of your equipment.

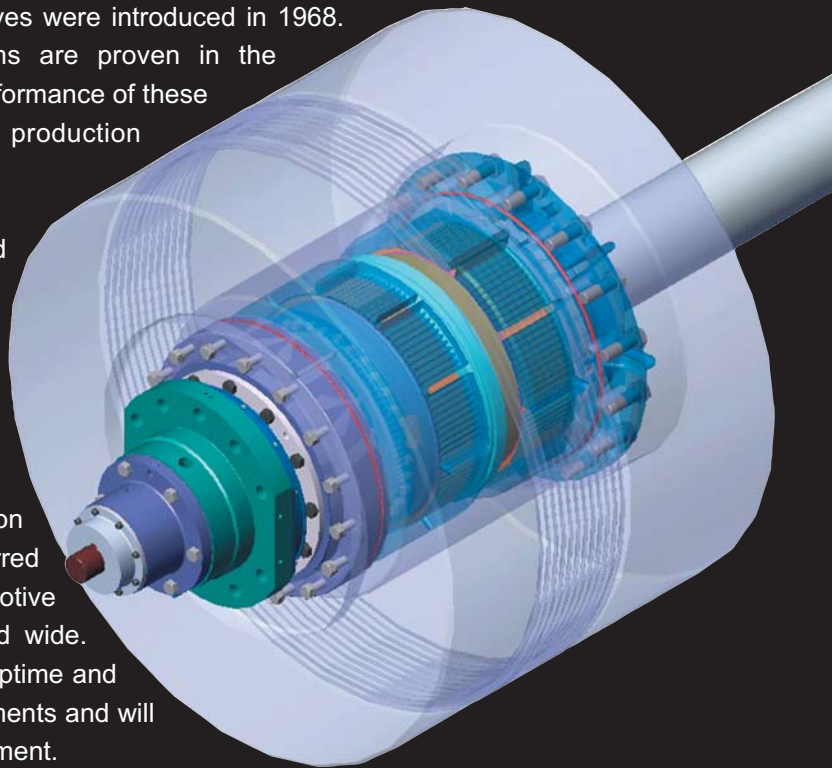

Press Pac® 2100 Series – Proven and Reliable

Press Pac® 2100 Series is the 3rd generation of Press Pac® technology that includes advanced hydraulic actuation and oil cooling technology.

Commercially introduced in 1991 after five years of field testing, our drive systems are the most rugged, durable press drives available on the market today. No other press drive matches the performance, durability and reduced life cycle cost of the Press Pac®.

Press Pac® Applications

- Stamping Presses
- Forging Presses & Upsetters
- Headers
- Press Brakes
- N.C. Turret Punch Press
- Metal Forming Equipment

Press Pac® Benefits

- Increased Production Rates
- Increased Reliability & Machine Uptime
- Reduced Life Cycle Costs
- Simple Installation
- Minimal Maintenance Requirements

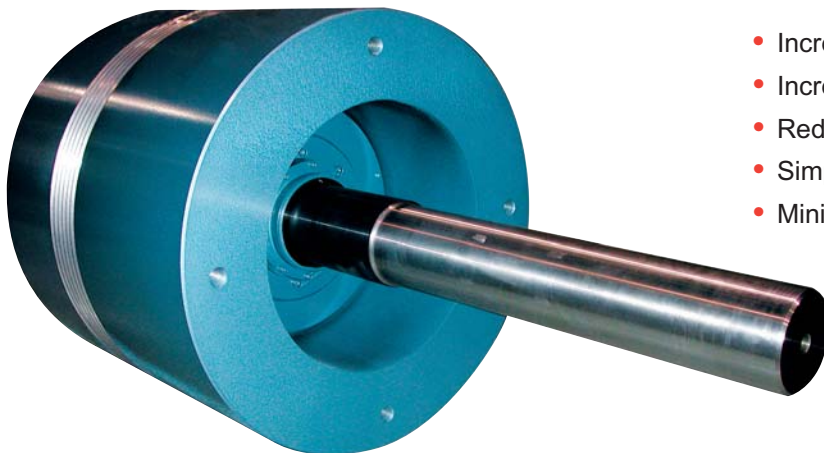

Oil Shear Drives For Metal Forming Equipment

Complete Drive System Engineering

The Press Pac® Oil Shear Press Drive System is a turnkey system that is ideally suited for retrofit applications on existing equipment. The 2100 Series is an integral drive unit with clutch/brake mounted internal of the flywheel on the drive shaft.

Custom mounting brackets and adaptors are designed to fit the footprint of the old clutch/brake and eliminates costly modifications and onsite machining of the press. The unit is easily adaptable to fit most geared press drive arrangements and mounting configurations.

The Press Pac® 2100 turnkey system includes the clutch/brake components, mounting brackets, design engineering and the installation support needed to retrofit the original clutch/brake system quickly and easily.

Press Pac® Drive Package

- Complete Drive System Engineering
- New Flywheel
- New Flywheel Bearings
- New Drive Shaft
- New Oil Shear Clutch/Brake
- New Clutch/Brake Housing
- New Mounting Brackets
- New Rotary Union
- New Hydraulic Tank/Circulating Oil System
- Field Service Technician Check Out

Circulating Oil System

Included with the conversion package, the circulating oil system and controls package comes completely assembled and tested at the factory before shipment. This system includes an oil tank with the pump motor, valves, dual press safety valve, heat exchanger, and temperature switch mounted to the tank.

The circulating oil system's main function is to control the clutch engagement pressure and to circulate cooling oil through the Press Pac® clutch/brake. The system is easily adjusted to precisely control clutch engagement pressure and stopping times. The efficiency and low inertia of the Press Pac® drive system, combined with the hydraulic actuation provides split second response time to start and stop the press. Smooth, noise free, cushioned engagement of the oil shear clutch/brake will extend life of your press parts and gear train.



Press Pac® 2100 Series Integral Press Drive System
With Flywheel, Mounting Bracket & Drive Shaft

Midwest Brake® Oil Shear Press Drive History

- | | |
|------|--|
| 1962 | 1st Retrofit of a Stamping Press with an Oil Shear Press Drive |
| 1968 | Press Pac® 1600 Series – Commercial Introduction Oil Shear Press Drive Pneumatically Actuated/Oil Cooled |
| 1986 | Press Pac® 2000 – Field Test Oil Shear Press Drive Hydraulically Actuated/Oil Cooled |
| 1991 | Press Pac® 2100 Series – Commercial Introduction Oil Shear Press Drive Hydraulically Actuated/Oil Cooled |
| 1994 | 500th Stamping Press – Retrofit |
| 1997 | Press Pac® 3200 Series – Commercial Introduction Oil Shear Clutch/Brake – OEM Design Hydraulically Actuated/Oil Cooled |
| 2002 | Over 4000 Stamping Press & Welding Press Drives Successfully Installed Worldwide |

Press Pac® 2100 Series Integral Press Drive Systems

Press Pac® 2100 Series Integral Drive System

The Press Pac® 2100 Series Integral Press Drive System is a hydraulically actuated / oil cooled, multiple disc, combination clutch/brake for metal forming presses.

- Hydraulic Actuation / Oil Cooling
- 10 Standard Clutch/Brake Models
- Torque Range 10,000 Lbs-ft thru 150,000 Lbs-ft
- Presses Up to 4000 Tons
- Soft Start / Soft Stop Control Package



Press Pac® 2100 Series Benefits

Increased Production Rate

A single stroke rate of up to 90% of the continuous strokes per minute can be achieved with Press Pac® 2100. Increased thermal capacity allows for more strokes per minute, more parts per hour and a substantial cost savings can easily be realized through the advanced oil shear technology.

Increased Press Speed

The speed of the press can generally be increased up to 25% without a gear change. The thermal capacity of the Press Pac® 2100 allows for a simple sheave change to increase the speed of your press, which increases more strokes per minute and ultimately more throughput.

Longer Clutch/Brake Life

The advanced circulating oil system delivers cool oil to lubricate friction discs. Oil shear technology, the viscous shearing of oil between alternating discs, transfers torque and drive inertia resulting in less wear on the friction disc surfaces.

Maintenance Free

Press Pac® provides millions of strokes with little to no maintenance or repair requirements and thus, will lower your annual maintenance cost.

Smooth, Quiet Engagement

Noise free, cushioned engagement of oil shear technology decreases gear train wear and extends the life of press parts.

Excellent Start / Stop Capability

Precise, repeatable clutch engagement and improved stopping times are easily achieved through simple set up and adjustments to the control system. Reduced stopping times can provide faster press cycle times and improve machine productivity.



Reduced Life Cycle Costs

Achieve up to 10 years of high volume production without any press downtime or costly repairs. Press Pac®, when compared to standard dry friction clutch/brakes, eliminates costly downtime to replace damaged parts, packings and worn out brake linings and presents a substantial cost savings of the life of your machine.

Oil Shear Drives For Metal Forming Equipment

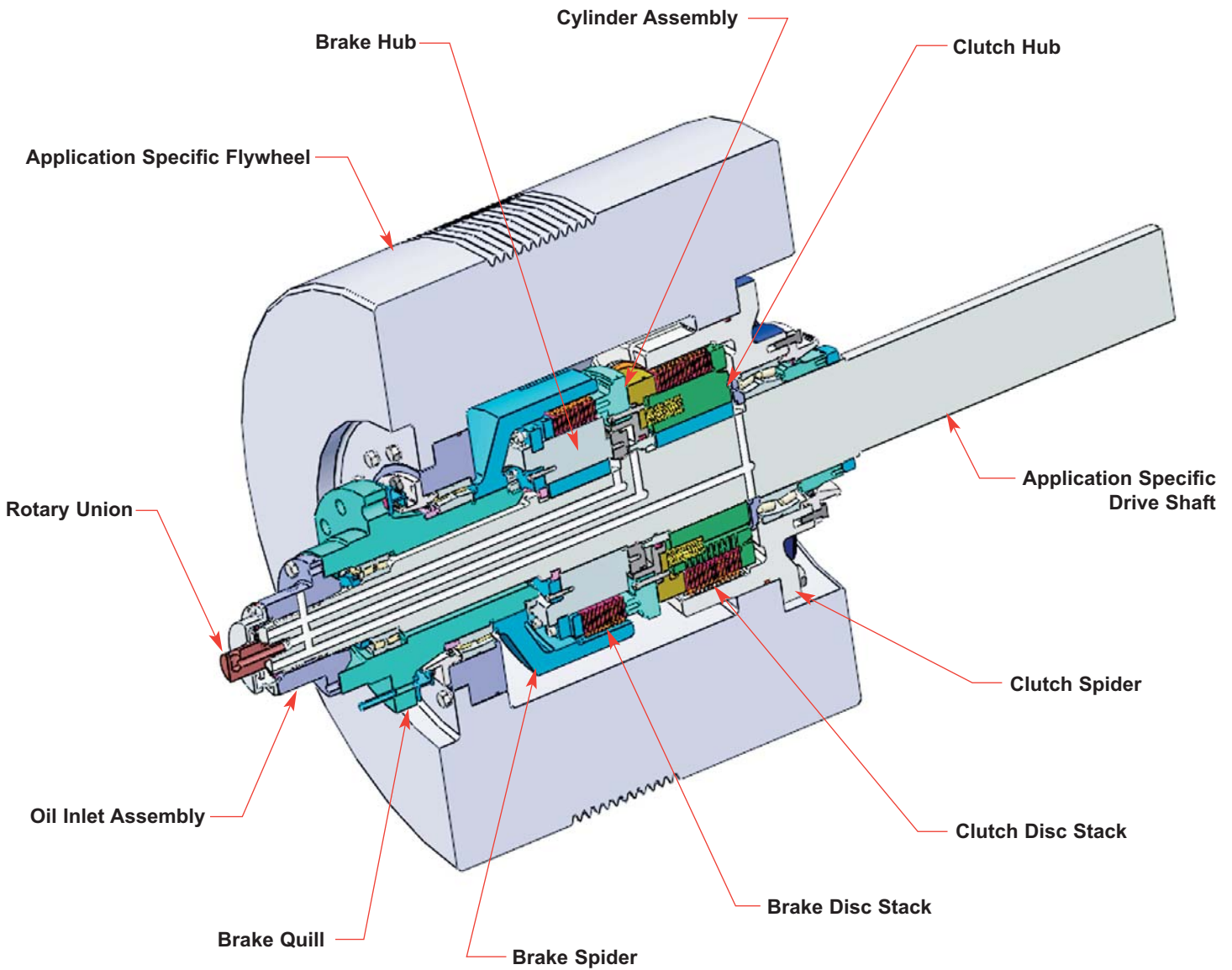

Circulating Oil System

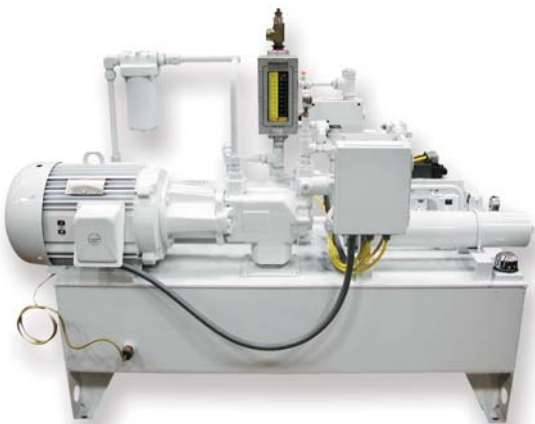

Press Pac® 2100 Specifications

MODEL NUMBER	CLUTCH TORQUE		BRAKE TORQUE	
	Lb-ft	Nm	Lb-ft	Nm
Integral Mounted				
2111	10,000	13,589	5,000	6,795
2121	20,000	27,178	10,000	13,589
2131	30,000	40,767	15,000	20,384
2141	40,000	54,356	20,000	27,178
2145	45,489	61,675	29,376	39,829
2161	60,000	81,534	30,000	40,767
2165	65,707	89,087	41,966	56,898
2181	80,000	108,466	53,038	71,910
2191	105,000	135,890	70,555	95,660
2195	150,000	203,830	106,358	144,202

Press Pac® 2100 Series Integral Press Drive Systems

Operation

Press Pac® 2100 Series Integral Press Drive Systems are designed specifically for use on stamping presses and metal forming equipment. The 2100 Series is an integral drive unit where the clutch/brake is mounted internal of the flywheel (5), on the drive shaft (8).

The unit is controlled by a central, single tank with a single hydraulic pump, dual press safety valve, heat exchanger, valves, temperature switch, flow meter, accumulators and filtering system. It controls the operation of the clutch engagement system and the clutch cooling system.

The bearing carrier (1) and the clutch spider (6) are bolted to the flywheel (5) and rotate continuously with the flywheel. The steel wear discs for the clutch (4) are driven by splines that are integral with the clutch spider (6); thus the steel wear discs are driven continuously at the same speed as the flywheel.

The steel wear discs for the brake (3) are identical to the steel wear discs for the clutch (4). They are restrained from rotation by splines on the brake spider (2), which is keyed to the quill (22). The quill is attached to a mounting bracket which is attached to the press crown (Not shown in diagram).

Clutch Engagement

The rest of the clutch/brake parts start and stop as the clutch is engaged and disengaged. When the clutch operating valve is energized, pressure is applied through the rotary union (18) into the drive shaft porting where it reaches the actuation chamber (9). The resultant force is applied to the cylinder assembly (11) causing it to move to the right. The piston (12) remains stationary relative to the drive shaft (8).

The initial movement of the cylinder assembly (11) compresses the brake springs (7) and releases the clamping force on the brake disc stack (3). Further travel of the cylinder assembly (11) applies a clamping force to the clutch disc stack (4). The current unit on page 6 is shown with clutch engaged. The clutch/brake is mechanically interlocked, which eliminates any possibility of clutch/brake overlap which decreases disc stack wear.

Brake Engagement

When the clutch operating valve is de-energized, oil is released from the actuation chamber (9). With decreasing clutch pressure, brake spring (7) force causes the cylinder assembly (11) to move to the left. This initial movement releases the clamping force on the clutch disc stack (4). Further travel of the cylinder assembly (11) applies a clamping force to the brake disc stack (3).



Oil Cooling

The drive cavity (14) is formed by the inside surface of the flywheel rim, the bearing carrier (1) and the clutch spider (6). The drive cavity is completely filled with hydraulic oil. Press Pac® units use a Type F Automatic Transmission Fluid.

Oil is supplied to the drive cavity (14) from an oil pump mounted on the circulating oil system. Oil is supplied to the unit through the cooling oil in port (20) on the oil inlet assembly (17). An oil manifold with a valve arrangement located on the oil tank, controls the flow of oil to the unit. The oil is directed through the cooling oil ports (15) and flushes the brake disc stack (3) and clutch disc stack (4) by means of drilled holes in the clutch hub (10) and brake hub (13).

The brake and clutch disc stacks are continually flushed with cool oil. The oil is circulated through the entire unit, cooling and lubricating the internal parts, bearings and seals.

Grooving and porting (not shown on the drawing) of the brake hub (13) and the pressure plate, also ensure proper oil movement through the disc stacks. Oil is returned from the drive cavity to the oil tank through the port in the quill (22) shown as cooling oil out (21).

This port is located on top of the quill (22). An extension pipe is attached to the oil return port, at a height above the inside surface of the flywheel rim. This ensures the drive cavity is always full of oil and avoids introducing back pressure into the drive cavity.

Oil Shear Drives For Metal Forming Equipment

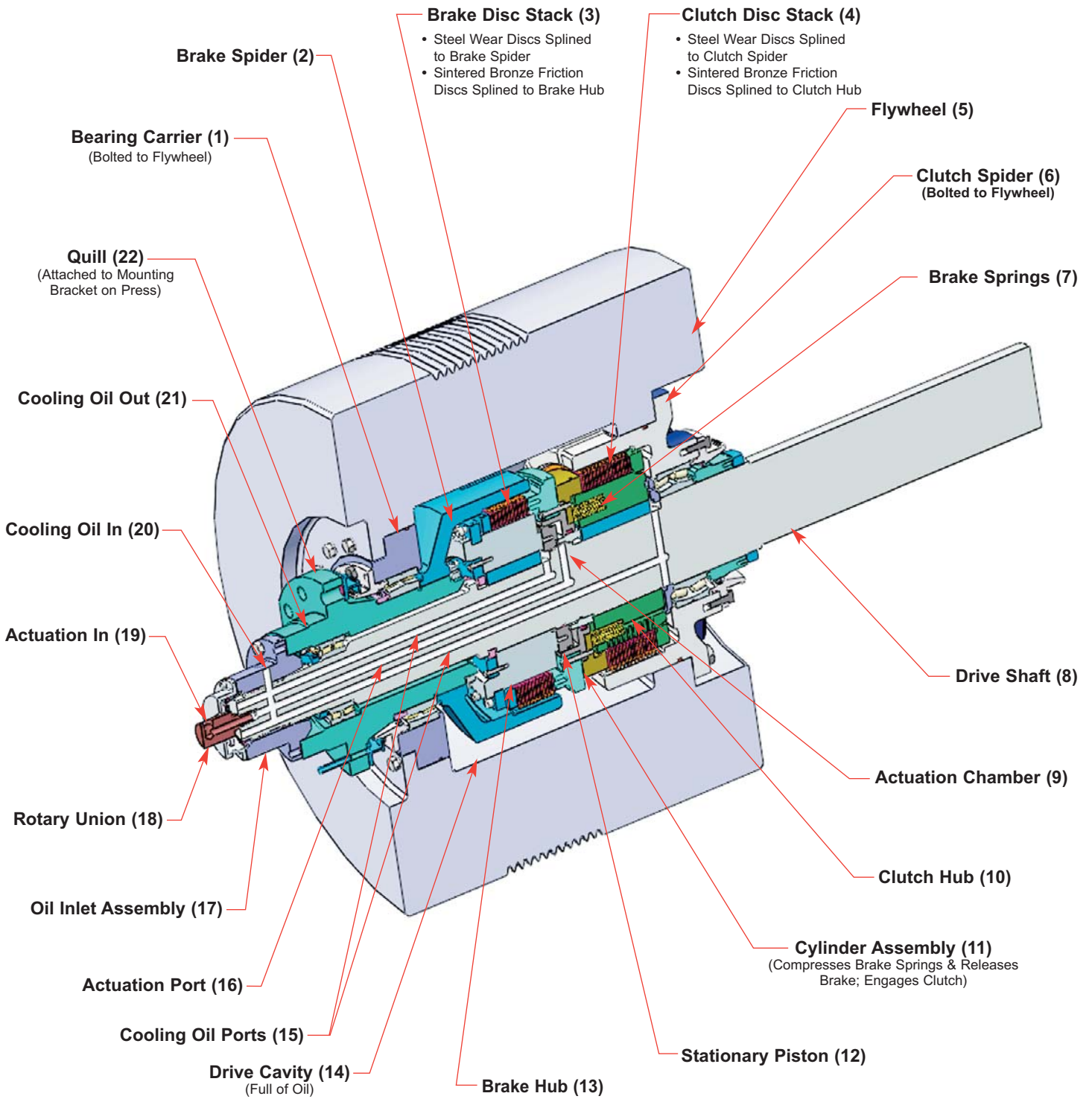

Press Pac® 2100 Series Integral Press Drive Systems

Installation

Press Pac® 2100 Series Integral Press Drive System is a turnkey package designed to mount as one integral unit for fast, easy installation. The Press Pac® unit comes fully assembled, tested and ready for installation.

Measurement of Press

A Midwest Brake® engineer will visit your facility to perform an analysis of your machine and the production process performed. At that time, the existing drive will be removed from the crown of the press so the existing press drive components can be measured.

Disassembly of certain drive components is necessary to design the conversion to the Press Pac®. These requirements are easily reviewed with a Midwest Brake® representative in preparation for measurement of the press.

Minimal Modifications To The Press

The Press Pac® 2100 Integral Press Drive System is custom designed and manufactured to minimize any modifications to the press crown. Most presses are easily and simply converted to Press Pac® with little to no modifications of your press.

After measurement of the press, our engineers design the mounting brackets, drive shaft and flywheel to fit in the same footprint of the old clutch/brake.

This minimizes any machining or modifications to the press and results in a quick, simple installation of the unit. Midwest Brake® will provide a detailed, step by step installation drawing upon shipment of the unit.

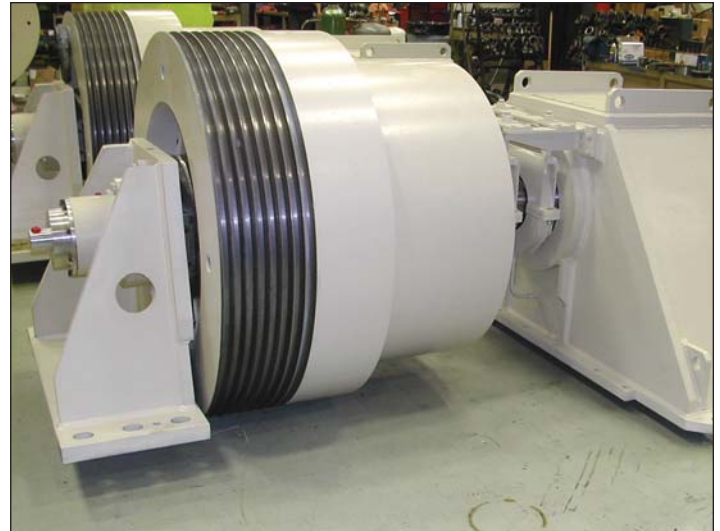

Press Pac® Drive Package Includes

- Complete Drive System Engineering
- Flywheel
- Flywheel Bearings
- Drive Shaft
- Oil Shear Clutch/Brake
- Clutch/Brake Housing
- Mounting Brackets
- Rotary Union
- Hydraulic Tank Circulating Oil System
- Field Service Technician Check Out



Tier 1 Automotive Stamping Plant
Presses Retrofitted With Press Pac® Hydraulic Clutch/Brakes



Oil Shear Drives For Metal Forming Equipment

Minimal Modifications & Simple System Integration

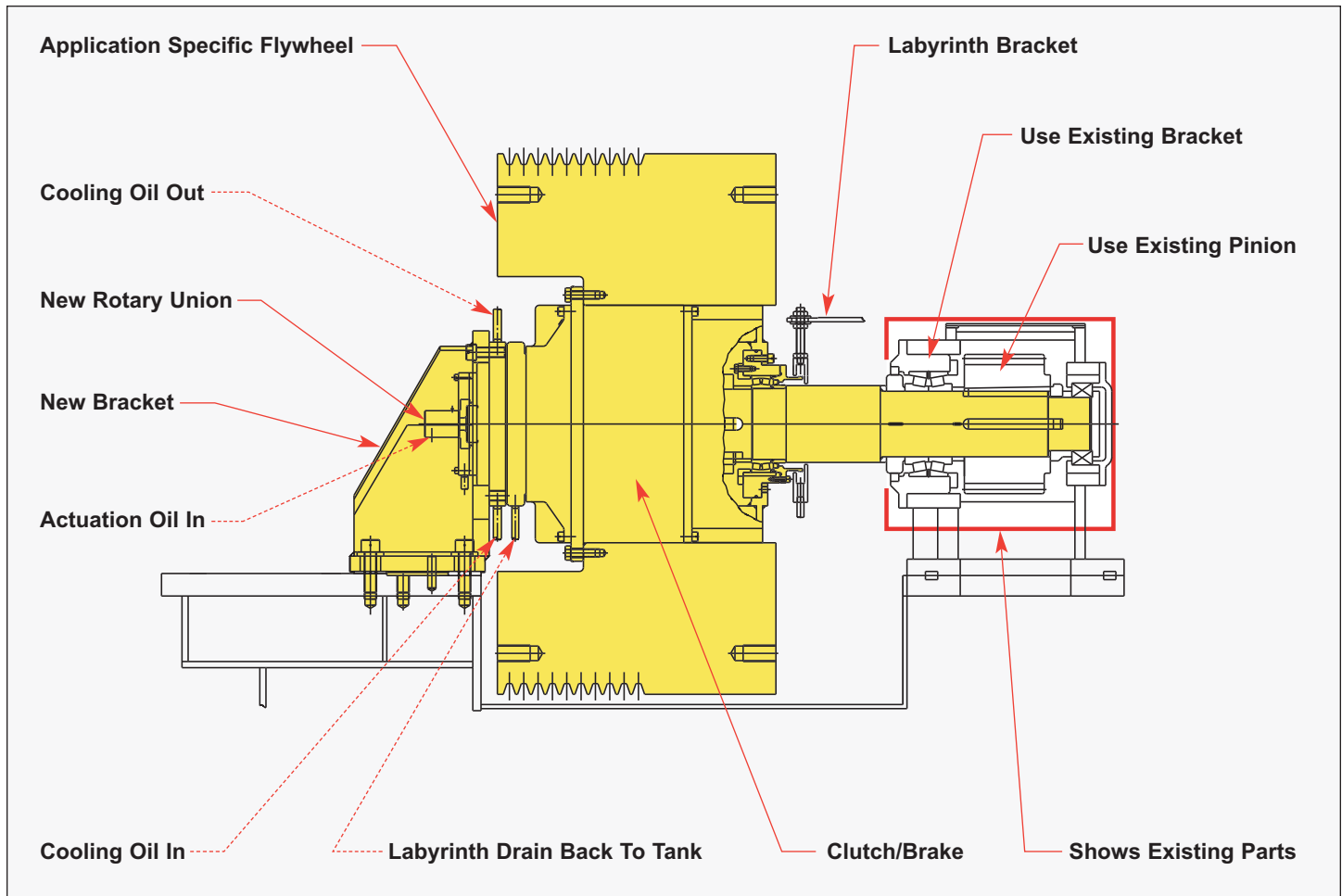

Design Features

Flywheel Design

The flywheel is designed to ideally have the same OD, ID and rim thickness of the original press flywheel. Flywheel grooves are measured and designed with the same groove pattern as the original press flywheel. The existing belt configuration duplicated. The new flywheel includes integral flywheel bearings which are self lubricated.

Motor

The main motor and the motor bracket locations do not need to be altered or moved, in most cases.

Pinion & Pinion Assembly

The pinion, pinion assembly, pinion saddles and mounting configuration are measured so the new drive shaft will mount in exactly the same position with little modification. (Pinion bore will need slight machining upon installation). The existing bearing specifications are designed into the conversion package to minimize design changes.

Standard Parts

Standard Oil Shear Clutch/Brake

The Oil Shear Clutch/Brake is a standard design that is encased in the custom designed flywheel. These parts are standard, off the shelf parts in stock and ready for shipment if needed.

Hydraulic Tank

The hydraulic tank provides the actuation pressure and cooling oil flow to the unit. The tank is a standard design utilizing standard, off the shelf components.

Press Pac® 2100 Series Integral Press Drive Systems

Hydraulic Actuation

The Press Pac® 2100 Series Integral Press Drive System uses hydraulic actuation to engage the clutch. The main circulating oil system uses a single pump mounted on a single tank where oil is pumped from the tank through the rotary union into the shaft bore. The fluid is delivered to the actuation chamber where the cylinder assembly is engaged.

Approximately 700 PSI of pressure is applied to the cylinder assembly. The cylinder assembly is used to compress the brake springs, releasing the brake. Since the clutch/brake is mechanically interlocked, the brake releases as the clutch engages. A mechanically interlocked clutch/brake eliminates overlap and prevents heat build up in the unit. Within the cylinder and piston arrangement, high temperature rated Viton Poly-Pac seals are used to provide long seal life and provide consistent, reliable operating pressure.



Advantages of Hydraulic Actuation

Smooth, Quick Stops & Starts

The Press Pac® 2100 Series unit operates at over 700 PSI actuation pressure. The higher pressure, when compared with air clutches which operate at a much lower air pressure, allows for a more compact, lower inertia design. The Press Pac® design incorporates a lower inertia, compact piston design that is more responsive and provides quicker stops and starts that can be easily adjusted to meet production requirements.

Closed Loop System – No Contamination

The hydraulic actuation system is a closed loop system that does not rely on an outside air source. In typical production environments using dry friction press drives, dirty, wet air is introduced to the clutch/brake using a pneumatic system. This leads to the contamination and corrosion of the piston assembly, which can lead to premature failure of the seals, thus limiting the life of your clutch/brake resulting in costly repairs. Further, the Press Pac® closed loop system will not expel air or contaminants into the manufacturing environment.

Quiet Operation - Low Noise

The Press Pac® hydraulic system is inherently quiet in operation. Pneumatic style, dry friction clutch/brakes tend to create noise upon engagement of the clutch and the brake. The engagement of the dry friction surfaces creates squealing and high frequency chatter that are not operator friendly. Additionally, exhaust from the cylinder of pneumatic units creates noise. The Press Pac® hydraulically applied brakes eliminates this condition by providing noise free operation.

No Air Pollution

Many modern facilities have eliminated the use of pneumatic, dry friction clutch/brakes due to the dust, lubrication oil and pollution that is expelled into the manufacturing environment. Small airborne wear particles are expelled from the pneumatic, dry friction clutch/brakes during every engagement. This dirt and dust contaminates the equipment and lowers air quality in the facility. The Press Pac®, utilizing the closed loop hydraulic system, eliminates this condition and provides pollution free operation.

Precise Control

Hydraulic actuation allows for precise control and adjustment of clutch and brake engagement. Fluid is essentially non-compressible and is easily controlled by the valve arrangement to deliver consistent pressure over time. The pressure can be adjusted to improve clutch engagement times or to soften clutch engagement. Likewise, the brake engagement can be controlled easily through introducing back pressure into the brake. This is easily adjusted to decrease stopping times and can be finely tuned to soften brake engagement.

Precise Inching/Jogging

The Press Pac® is a low inertia, compact design with excellent thermal capacity. Precise inching and jogging can be achieved due to the increased cooling capacity and easily controlled hydraulic actuation. The unit is able to easily handle this operation where other units may overheat.

Oil Shear Drives For Metal Forming Equipment

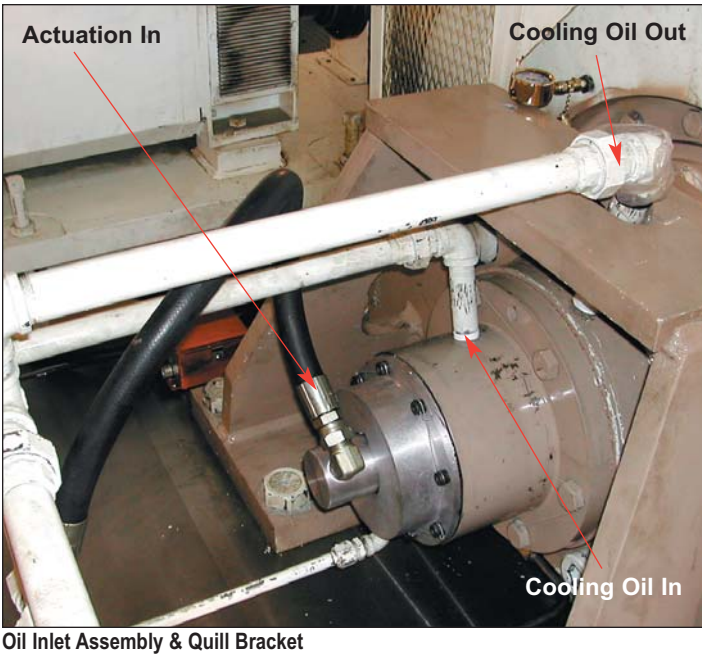
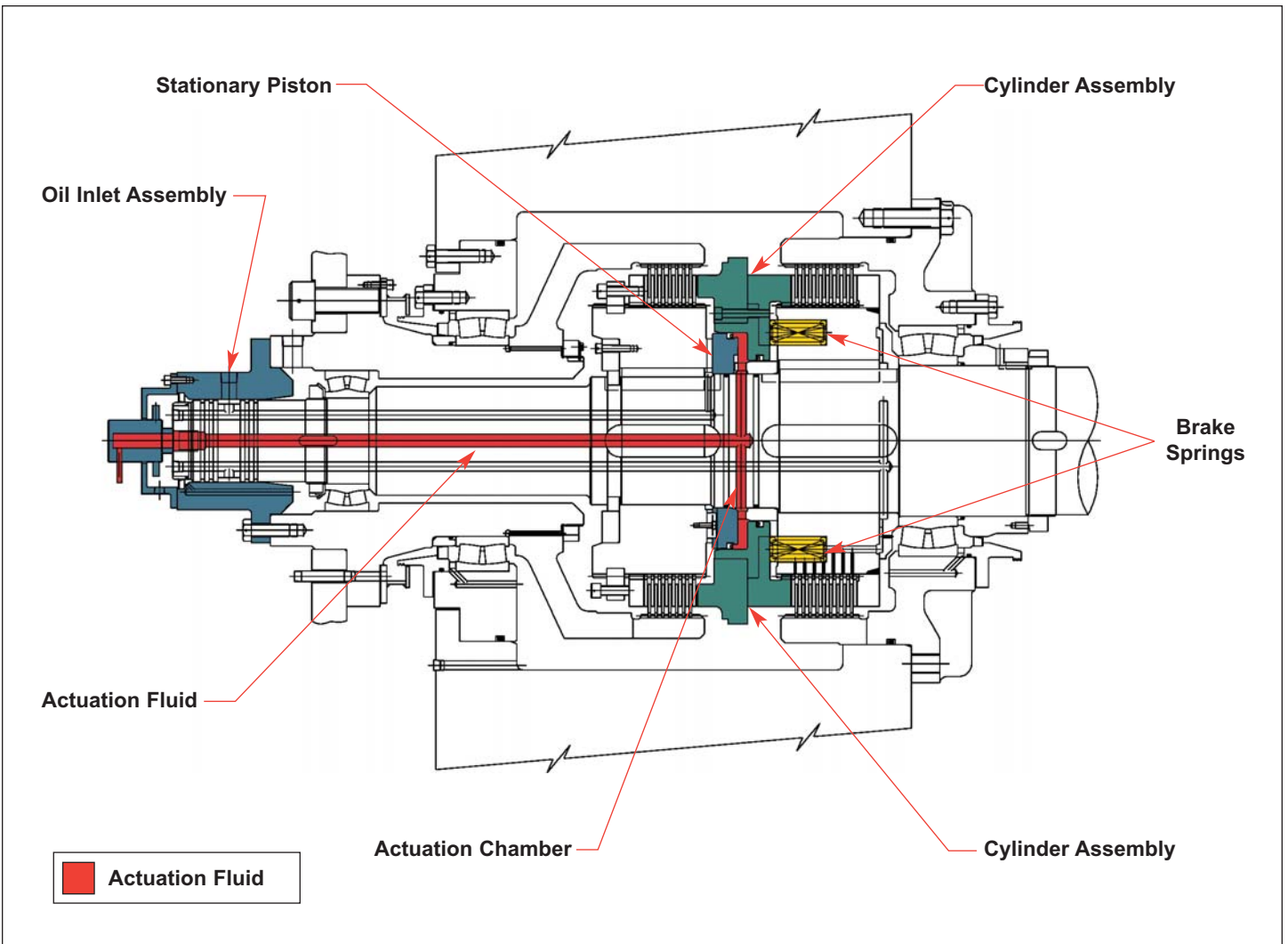

Press Pac® 2100 Series Integral Press Drive Systems

Oil Cooling

The Press Pac®'s main design feature is to extend the life of the unit and increase the MTBF (Mean Time Between Failure) of the equipment. The main reasons for longer life of the unit are:

Patented Reverse Cooling Oil Flow

The Press Pac® unit has a patented "Reverse Oil Flow" which forces cooling oil through the shaft bore and flushes the brake discs and the clutch discs with cool oil. The oil is forced through the unit at a high rate and returns it to the tank to where it is cooled and recycled.

Friction Disc Lubrication – Forced Lube

The patented "Reverse Oil Flow" forces cooling oil directly into the clutch and brake disc assemblies through shaft bore porting and forces the oil back to the tank to be cooled. This forces oil in between the friction disc and the wear plates and provides cooling and separation between these discs. The friction discs have a special groove pattern that increases cooling flow through the disc stacks.

Clutch & Brake Stacks – Flushed Heat Dissipation

The clutch and brake disc stacks are constantly flushed with fresh, cool oil allowing for maximum heat dissipation from the shaft bore porting. The unit is completely full of oil and the constant flushing of the disc stacks leads to long life of the sintered bronze friction discs.

Flywheel Bearings – Continually Lubricated

The flywheel bearings are an integral part of the drive unit and are lubricated by the circulating cooling throughout the unit. This extends bearing life and extends the life of the Press Pac® unit.



Hydraulic and Pneumatic Systems Inspection

Shaft Seals – Continually Lubricated

The shaft seals are continually lubricated which allows them to seal properly. Seal "weepage" is inherent in seal design. The lip of the oil seal must run dry to seal causing the seal to wear. Once the seal starts to weep, the lip is lubricated and wear is greatly diminished. Midwest Brake® utilizes labyrinth style brackets to capture seal "weepage" and return to tank.

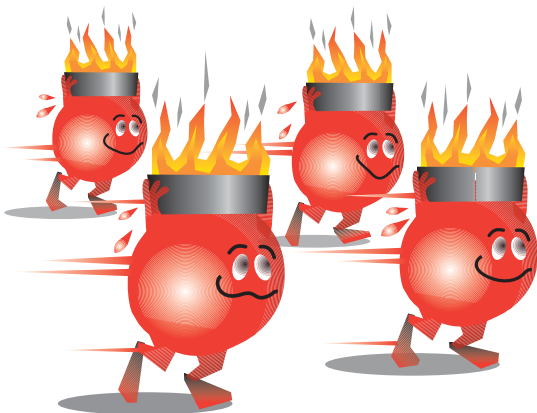

Oil Shear Drives For Metal Forming Equipment

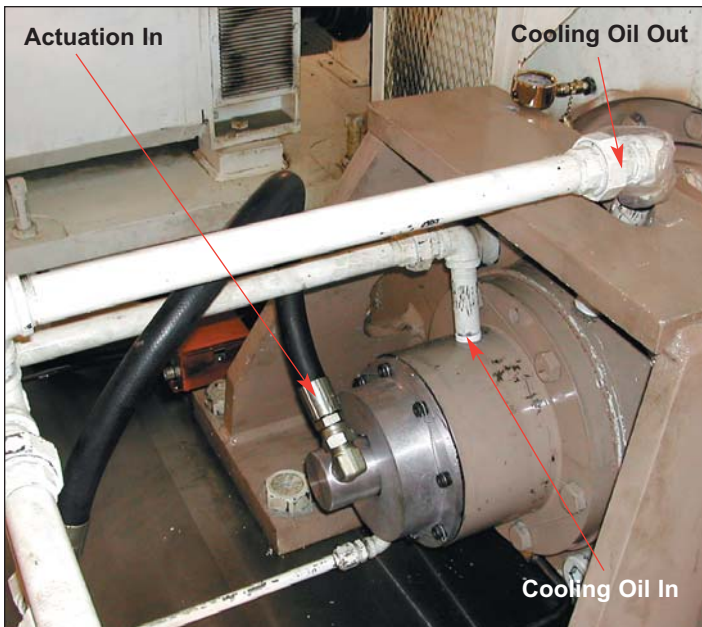
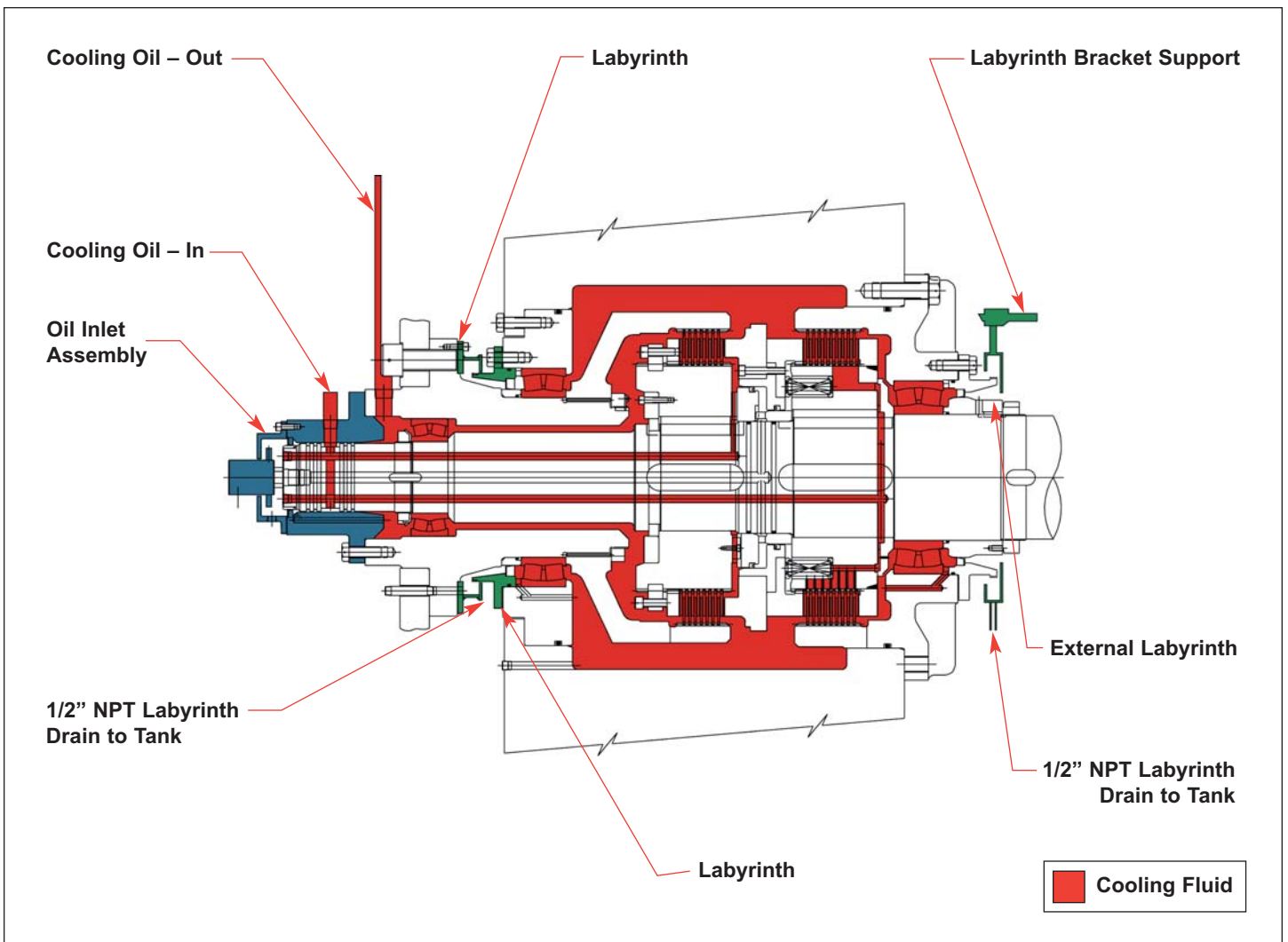

Oil Inlet Assembly & Quill Bracket

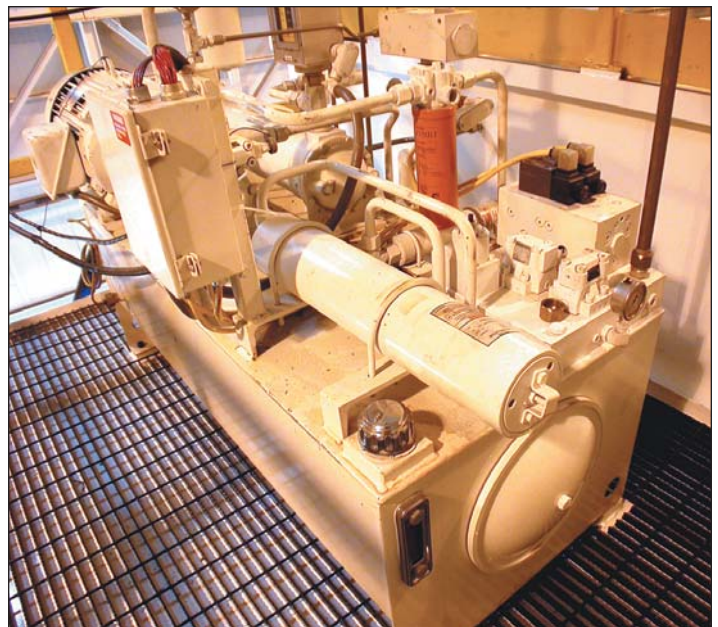

Circulating Oil System

Press Pac® 2100 Series Integral Press Drive Systems

Circulating Oil System

Midwest Brake® offers a complete controls package for precise control of the Press Pac® 2100 unit. This closed loop system includes a single tank with a single hydraulic pump, dual press safety valve, heat exchanger, valves, gauges, accumulators, temperature switch and oil filtering system. All the control components and gauges are mounted on a central tank for simple inspection and adjustment.

Superior Heat Dissipation

Superior heat dissipation is an inherent feature in the oil shear design. The heat generated during engagement and disengagement of the disc stacks is dissipated in several ways.

First, since the flywheel is rotating continuously during press operation, heat is carried away through the housing and flywheel.

Second, oil is circulated from the tank through the drive cavity, through the friction discs and returned to the tank where the oil is cooled through a heat exchanger.

Continuous oil flow through the unit keeps the temperature uniform through the whole system and eliminates “hot spots” where overheating might occur. Normal operating temperature of the unit is approximately 140°F - 180°F.

Over Temperature Switch

An over temperature switch monitors the oil temperature on the oil return line after the oil flows through the unit and returns to tank. Set at 210°F, the over temperature switch is interlocked with the main motor and will shut down the unit in the event of overheating, preventing damage to critical internal parts.

Flow Switch

A flow switch monitors the supply of oil to the unit. If the flow rate drops to a critical level, a signal is sent to shut down the unit to prevent overheating of the clutch/brake and prevent damage to critical components of the unit.

Filtering System

The system uses a 10 micron filtering system for both the actuation oil line and the cooling oil line. The high pressure filter is used to eliminate contaminants from reaching the dual press safety valve and the clutch/brake piston seals. The low pressure filter prevents contaminants from reaching the drive cavity and damaging critical internal components.



Hydraulic Actuation System

The hydraulic actuation system provides precise control and adjustment of the clutch/brake for fine tuning starting and stopping time performance. Precise, repeatable clutch engagement and improved stopping times can be achieved through simple adjustments in control system. Faster cycle times and improved machine productivity can be achieved. This system is included on our standard circulating oil system.

Item 1	Check Valve
Item 2	Orifice Manifold
Item 3	Orifice
Item 4	Gauge
Item 5	Check Valve
Item 6	Accumulator
Item 7	Seat Valve
Item 8	Back Pressure Valve
Item 9	Gauge
Item 10	Flow Switch (Cooling Oil)
Item 11	Heat Exchanger (Oil To Water)
Item 12	Relief Valve (Cooling Oil)
Item 13	Relief Valve Spring
Item 14	Low Pressure Filter
Item 15	Low Pressure Filter Element
Item 16	Relief Valve
Item 17	Vane Pump
Item 18	Strainer
Item 19	TEFC Pump Motor
Item 20	Level Switch
Item 21	Oil Tank
Item 22	Temperature Switch
Item 23	Ball Valve
Item 24	Pilot Check Valve
Item 25	High Pressure Filter
Item 26	High Pressure Filter Element
Item 27	Accumulator
Item 28	Orifice
Item 29	Dual Press Safety Valve
Item 30	Manifold

Oil Shear Drives For Metal Forming Equipment

Soft Start / Soft Stop Valve Package

A soft start / soft stop valve package is offered as an option if enhanced control of the clutch/brake is required. This valve package allows for the clutch to be finely tuned for a soft engagement, then apply full pressure for the working portion of the stroke.

Likewise, it will provide a reduced brake torque, then apply full braking torque for smooth, quick stops that can be easily adjusted to meet your operating requirements. In the case of an emergency stop condition, the system is set to provide

full brake torque in order to stop the press safely and quickly.

The soft start / soft stop valve package provides superior performance for press builders or stampers who want to extend the life of press parts through the cushioned engagement of hydraulically controlled clutch/brakes. This is an optional package that should be specified during the inquiry process

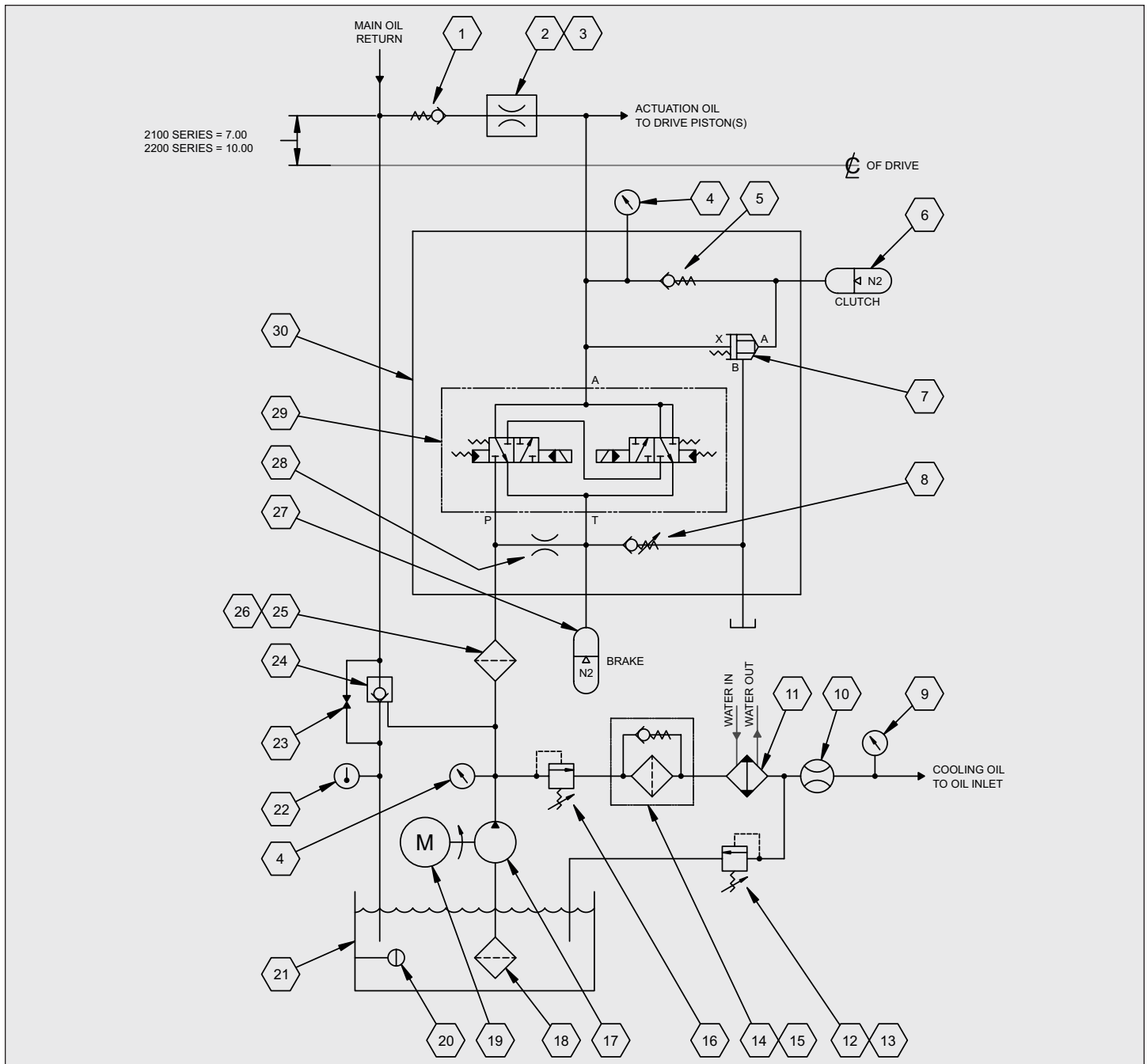

Press Pac® 2100 Series Integral Press Drive Systems

Oil Shear Principle

Press Pac® 2100 Series Integral Press Drive transmits torque through the shearing of oil molecules between alternating sintered bronze friction discs and steel wear discs. The viscous shearing of the oil (automatic transmission fluid) dissipates the heat generated from the operation of the Press Pac® and is carried away by the continuous circulation of the oil.

The oil shear principle is the primary reason oil shear clutch/brakes offer extremely long service life and superior reliability.

Press Pac® drive systems incorporate a true oil shear into the design where the friction discs are continuously flooded with oil to lubricate and cool friction disc surfaces. A true oil shear actually cuts across the film of oil molecules that is maintained between the alternating disc surfaces.

The oil itself acts as efficient power transmission medium, which relieves the mechanical friction surfaces of much of the work. The oil effectively absorbs and dissipates heat while lubricating the clutch/brake.

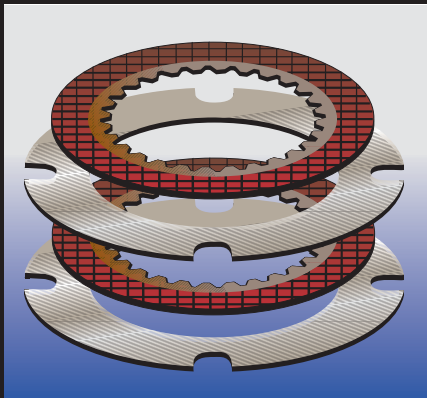

The Press Pac® Clutch/Brake contains a stack of alternating discs. Press Pac® utilizes advanced composite sintered bronze friction discs and steel disc wear plates.

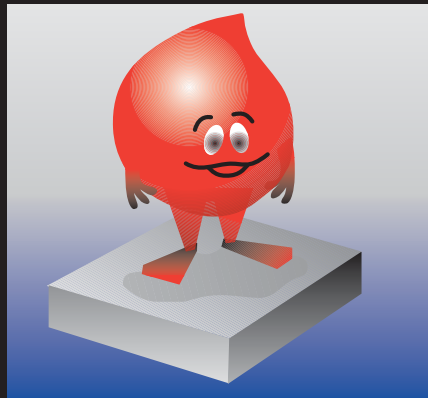

Operation of the Press Pac® Clutch/Brake begins with the oil film which is made up of multiple oil molecules. Molecules of oil are attracted to one another, giving oil defined viscosity.

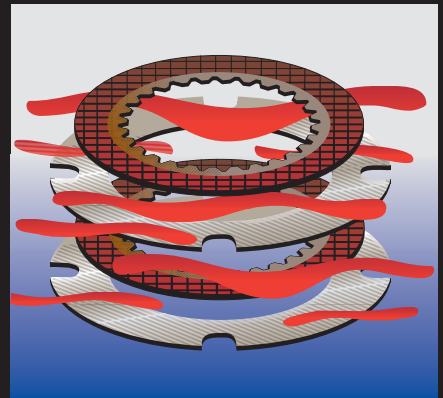

The Press Pac® Clutch/Brake maintains a film of oil between the friction surfaces, through which torque is transferred.

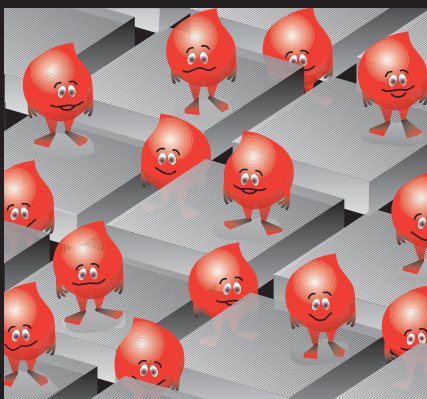

Oil molecules ride on and between the friction discs and act like small hydrodynamic bearings.

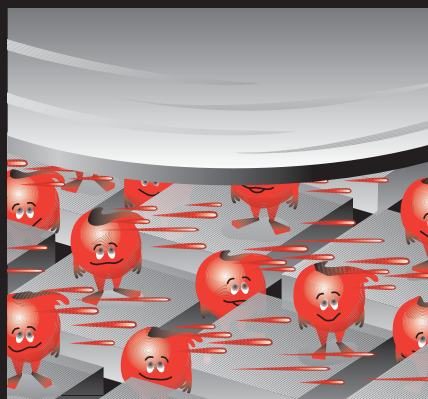

As the friction discs begin to rotate, the opposing drive cuts across the film of oil molecules.

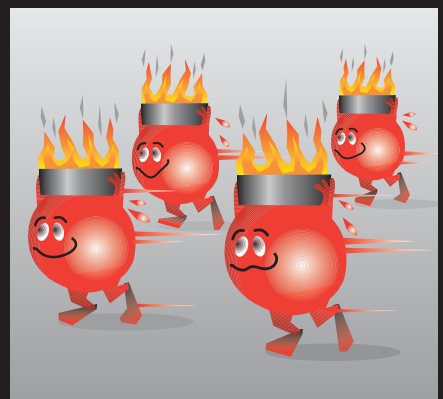

The kinetic energy (heat) generated during operation of the Press Pac® Clutch/Brake is carried away by the continuous circulation of the oil molecules.

Oil Shear Drives For Metal Forming Equipment

Oil Shear Principle – Press Pac® Drive System

The Press Pac® clutch/brake utilizes a circulating oil system that keeps the housing completely full of oil and continually pumps oil through the clutch/brake system and back to tank. All working parts of the Press Pac® are immersed in a bath of continuously circulated Type F – Automatic Transmission Fluid.

Power from the main motor is transferred from the belt driven flywheel to the drive shaft through a clutch disc stack, which is comprised of an alternating series of sintered bronze friction discs and steel wear discs.

Starting torque initiates the viscous shear of the oil film between the sintered bronze friction discs, which are splined to the hub, and the steel wear discs which are constantly rotating with the flywheel. The hub is mounted on the drive shaft or quill, depending on the clutch/brake model, using keyways or a locking assembly.

At the instant of oil shear, rotation of the steel wear discs impels the oil film, setting the sintered bronze friction discs in motion. Within a split second, synchronous speed is attained. As the hydraulically actuated clutch becomes fully engaged, the discs are firmly clamped together by over 700 PSI of hydraulic pressure. During the lock up of the clutch disc stack, residual oil is expelled from between the alternating discs, eliminating slippage and creating positive power transmission.

Over 90% of the starting inertia is absorbed by a thin, positive oil film between the alternating discs. The oil itself acts as the power transmission medium, which results in very little wear on the sintered bronze friction disc surfaces. During the first “wear in” of approximately one million cycles, there is approximately .001 (.0245mm) per surface wear. After the first wear in is completed, further wear is almost non-existent.

Similarly, braking torque is initiated by the viscous shearing of the oil film. However, the brake pressure is achieved through spring applied pressure, rather than hydraulic applied pressure that is used in clutch actuation.

Oil Shear Principle Advantage

The primary advantage of oil shear technology is to dramatically extend the life of friction surfaces. Friction creates heat, which is inherent in any clutch/brake operation. Direct friction surface contact, which is required for positive torque transfer, causes abrasion and wear on the disc surfaces. Friction discs that are coated with a film of oil are far better suited to withstand the heat and wear because the oil efficiently absorbs heat and protects surfaces from contact abrasion.

Advantages

- Little to no wear of plates in the disc stack
- No brake fade
- More precise operation of the clutch/brake
- Increased clutch/brake reliability
- Increased machine uptime

Oil Shear – Increased Thermal Capacity

A large capacity hydraulic reservoir tank is mounted below the drive unit to pump oil through the clutch/brake and returned to tank where it is cooled and reused. The heat generated from the start/stop inertia of the Press Pac® is absorbed into the oil, circulated from the unit back to the tank where the heat is rapidly dissipated. The Press Pac® circulating oil system uses a state of the art heat exchanger to provide heat dissipation and cool the oil for reuse.

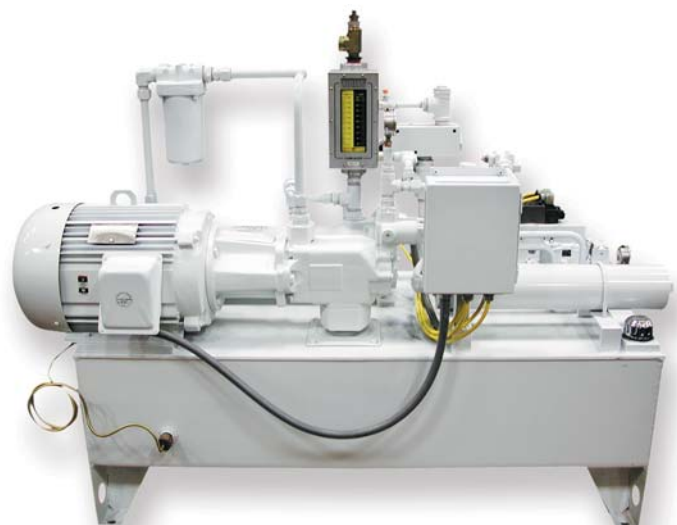
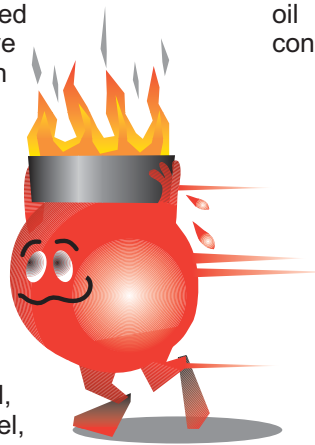
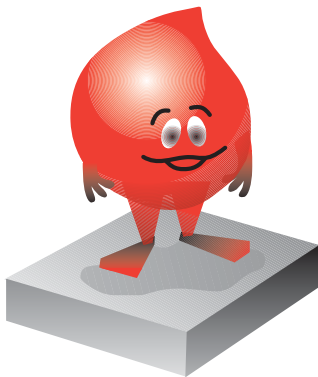

Press Pac® 2100 Series Integral Press Drive Systems

Oil Shear vs. Dry Friction

Press Pac® oil shear clutch/brake will outlast dry friction pneumatic clutch/brakes in some cases up to 10 to 1. Dry friction pneumatic clutches utilize the slippage of dry friction surfaces against wear surfaces to absorb inertia and generate torque. Full engagement of the dry friction surface occurs only after considerable slippage and wear occur. This causes wear of both friction material and wear plate surfaces. Without adequate heat dissipation, the friction surface degrades rapidly, requiring frequent adjustment and disc replacement of both friction discs and wear surfaces.

Some dry friction pneumatic clutch/brakes used on presses are mechanically interlocked; meaning one piston both releases the spring set brake and applies clamping force for the clutch. These mechanically interlocked units have most of the clutch/brake mass mounted on the drive shaft and often represent 80 percent of the total inertia of the press that the clutch/brake must stop and start.

Press builders introduced “low inertia” clutch/brake design in the 1940’s in an effort to reduce the start-stop inertia. This type of design requires separate pistons to release the brake and engage the clutch. The start-stop inertia with this type of design is still usually 60 percent or more of the total inertia.

The trip rate of a press equipped with a dry friction clutch/brake is limited because the mass of the unit determines its heat dissipation capacity, but if this mass is increased, the inertia that must be started and stopped is increased. These factors define a closed loop format from which it is impossible to escape when trying to increase the performance of the system.

Press Pac® 2100 is a compact, very low inertia design that provides superior stopping time performance with precise repeatable performance.

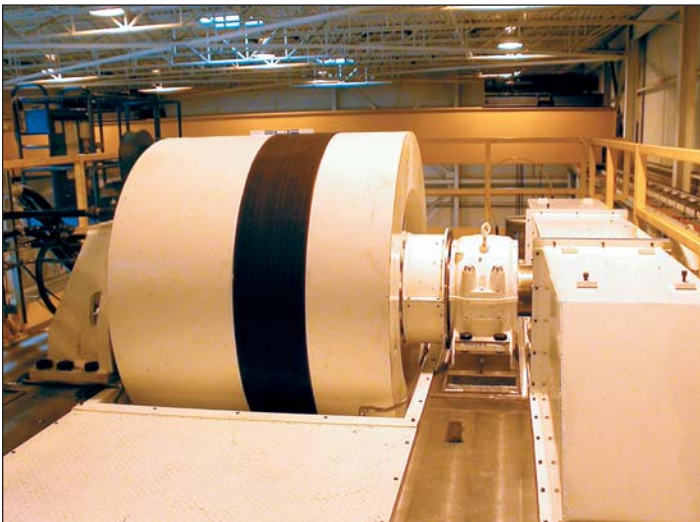

Press Pac Oil Shear Press Drive – Hydraulic Actuation



Dry Friction Pneumatic Clutch/Brake



Sintered Bronze Friction Disc



Dry Friction Clutch Disc

Oil Shear Drives For Metal Forming Equipment

	Oil Shear	Dry Friction
Transmission of Starting Torque From Flywheel to Drive Shaft	Viscous Oil Shear Between Discs	Slippage of Dry Friction Surfaces Against Each Other
Full Operation	Lockup of Discs – After Most of Work is Done by Oil Shear (Drive Shaft is in Motion Before Discs Engage)	Lockup of Discs – After They Have Slipped For Considerable Time Putting Drive Shaft In Motion
Braking Action	Viscous Oil Shear Between Discs	Slippage of Dry Friction Surfaces Against Each Other
Full Stop of Press	Lockup of Brake Discs – After Press has Decelerated Through Oil Shear	Lockup of Brake Discs – After Disc Slippage has Decelerated Press
Dissipation of Heat	Circulating Oil System with Heat Exchange Flushes Discs Continually	Air Circulation
Maintenance	Little to No Maintenance	Constant Maintenance
Adjustment of Clutch/Brake	Self Adjusting Clutch / Brake	Constant Adjustment Needed
Friction Discs	Sintered Bronze – Long Lasting	Dry Friction – Frequent Reline Needed
Brake Fade	No Brake Fade	Constant Brake Fade
Flywheel Bearings	Self Lubrication – Integral to Flywheel	Manual Lubrication
SPM - Cycle Rate	Up to 90% Single Stroke Rate	Up to 50% Single Stroke Rate
Inching / Jogging	Unlimited	Limited to Heat Dissipation of Friction Material
Installation	Simple Installation Little to No Machining/Modification	Difficult Installation Major Changes to Press Components Machining Needed On Site
Installation Time	7-10 Days	2-4 Weeks
Controls	Accel / Decel Adjustment	Air Is On / Off – Less Controllable
Environment	No Dirty Air Expelled Into Atmosphere No Friction Lining Expelled Into Air	Air Expelled Into Atmosphere Friction Lining is Expelled Into Air
Noise	Quiet Engagement of Clutch/Brake	Noisy, Squealing Engagement of Clutch/Brake
Testing	Unit Fully Tested Before Installation	Press Used as Test Stand During Installation
Responsibility	One Company, One Responsibility	Clutch Manufacturer & Machine Repair Co. Dual Responsibility

Press Pac® 2100 Series Integral Press Drive Systems

Testing

The Press Pac® 2100 Series Integral Press Drive System is unique because it is the only hydraulic clutch/brake that comes fully assembled and factory tested.

The Press Pac® is assembled and installed on a test stand at Midwest Brake®. The unit is connected to a main motor, piped to the circulating oil system and filled with oil. Not only is the integral drive system tested, but the circulating oil system supplied to the customer is fully piped, pressure tested and cycled during the testing procedure. A series of quality checks, tests and inspections are performed and documented.

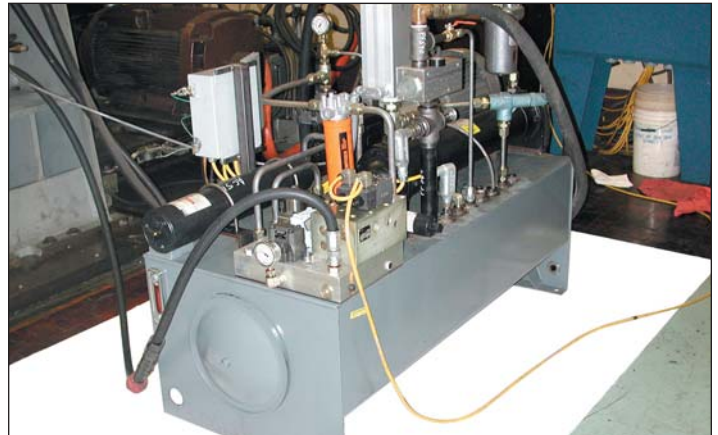

1. Press Pac® Assembly

The Press Pac® unit is fully assembled on the factory floor. The clutch/brake components are assembled on the drive shaft by a team of mechanics and prepared for testing.

2. Testing

The fully assembled Press Pac® is installed on the test stand and run through a series of checks that include run out measurement, temperature monitoring, vibration analysis and leak inspection. Factory certification and testing of the unit ensures that the unit will run properly and the press will not be used as a test stand during installation.

3. Run Out

Run out and concentricity on the diameters, facing of the flywheel, and drive shaft are measured and documented to ensure they are within factory specifications. This check ensures the unit will operate properly and increase the uptime of your the press.



4. Circulating Oil System Tested

The circulating oil system and actuation system are tested with the Press Pac® 2100 Series Integral Drive System for a period of 8 hours. Testing of the system confirms the functionality and performance of the oil system components.

5. Temperature

Temperature is monitored throughout the testing procedure and readings are recorded as part of the inspection report. Normal temperature readings confirm the proper functioning of the clutch/brake and the cooling system.

6. Flywheel Dynamically Balanced

The unit is dynamically balanced while on the test stand to ensure proper operation and long life.

7. Vibration Analysis

A vibration analysis is performed to certify the unit is operating within acceptable limits and is properly balanced. (Please note this is not a standard feature, but is available as an option).



Oil Shear Drives For Metal Forming Equipment

Preventative Maintenance

The Press Pac® 2100 Series Integral Press Drive System is designed to maximize the uptime and reliability of the machine. A preventative maintenance program is simple, straight forward and can be tailored to meet your production requirements. Midwest Brake® offers experienced Field Service Technicians that can perform annual inspections of your unit or train the customer's maintenance personnel to perform these inspections.

Preventive Maintenance Schedule

- Oil Leaks – Visual inspection monthly
- Oil Temperature – Inspect daily during initial installation, then every six months thereafter.
- Filter Element – Change monthly for the first three months of operation, then every six months thereafter.
- Change Oil and Clean Tank – Annually

Inspection

Midwest Brake® offers qualified, expert Field Service Technicians to perform factory certified inspection of the Press Pac® Clutch/Brake drive system, hydraulic system and related press systems.

Our technicians have years of experience in press related service including: Press Inspections, Press Assembly, Press Repair and Clutch/Brake Assembly, Trouble Shooting and diagnosis.



Clutch and Brake Inspection

Factory Certified Rebuild

Midwest Brake® offers fast, reliable factory certified rebuild and repair services for all Press Pac® units. We can inspect, disassemble, repair and rebuild the unit with OEM manufactured parts.

The Midwest Brake® factory certified rebuild will restore the unit to a like new condition, complete with a one year factory warranty.

The unit will be returned to the customer facility fully tested, painted and ready for assembly onto the press. Thus, you can be assured your unit will operate as designed and specified.

- Fast Teardown & Disassembly
- Complete Inspection
- OEM Repair Parts In Stock
- One Year Warranty
- Fully Tested & Pressure Checked
- Factory Support – Installation & Check Out

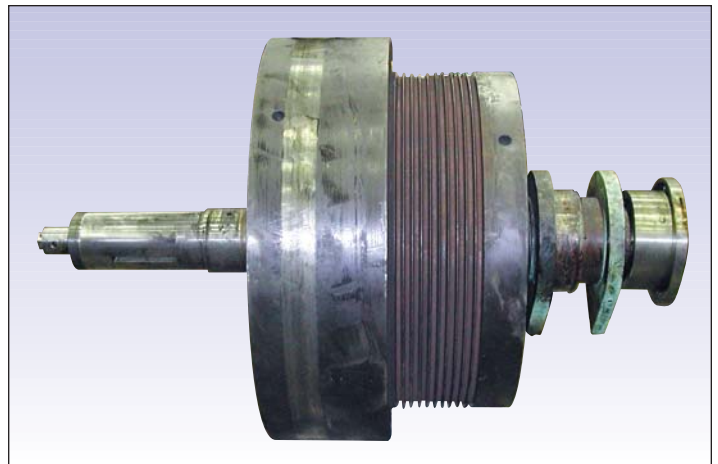

Before Factory Rebuild

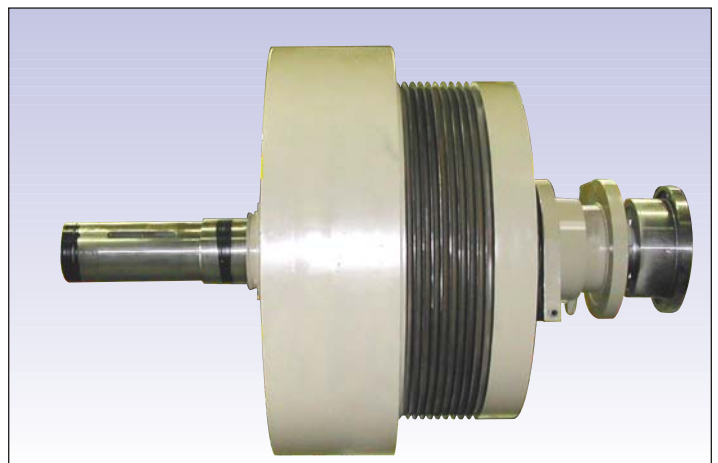

After Factory Rebuild

Press Pac® 2100 Series Integral Press Drive Systems

Installation Schematic

The Press Pac® 2100 Series Integral Press Drive System is designed for multiple press drive configurations. Midwest Brake® has not encountered a geared press design, world wide 50 - 4000 tons that cannot be successfully converted to Press Pac®.

Examples of some of the popular mounting arrangements are shown below as a point of reference for understanding our product offering.

Should you have requirements that are different than what are shown here, Midwest Brake® offers other Press Pac® products that can accommodate your needs.

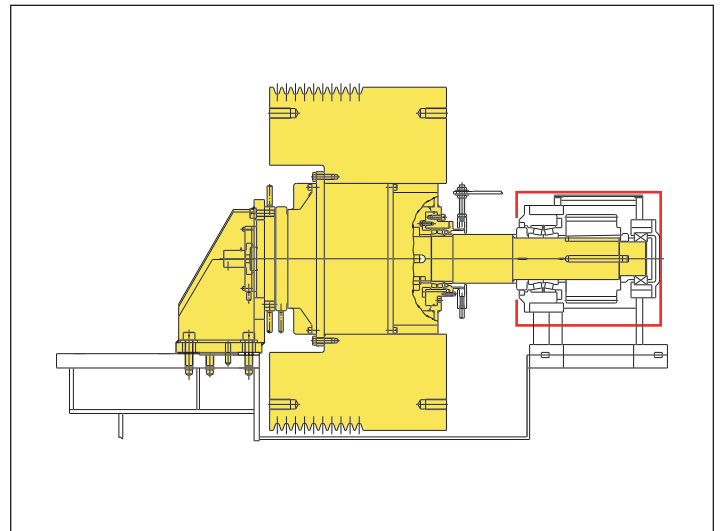

Standard Top Mount – Short Bracket

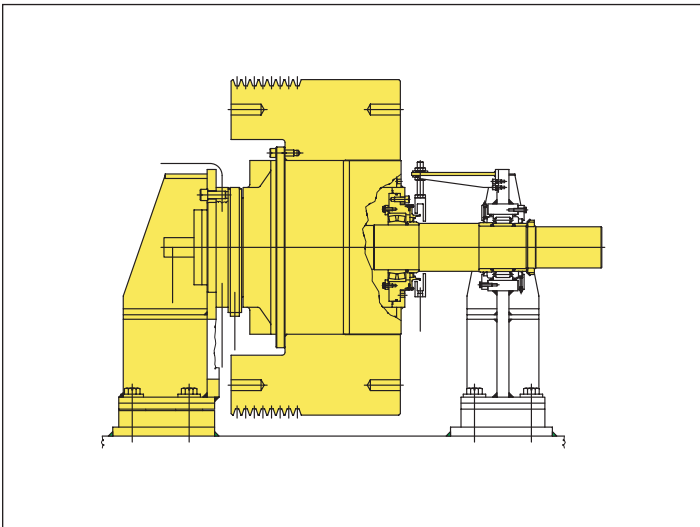

Standard Top Mount – Long Bracket

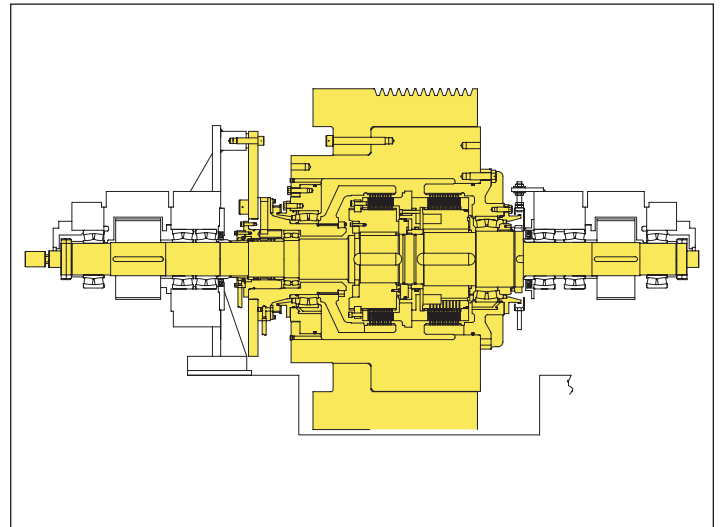

Dual Pinion Style

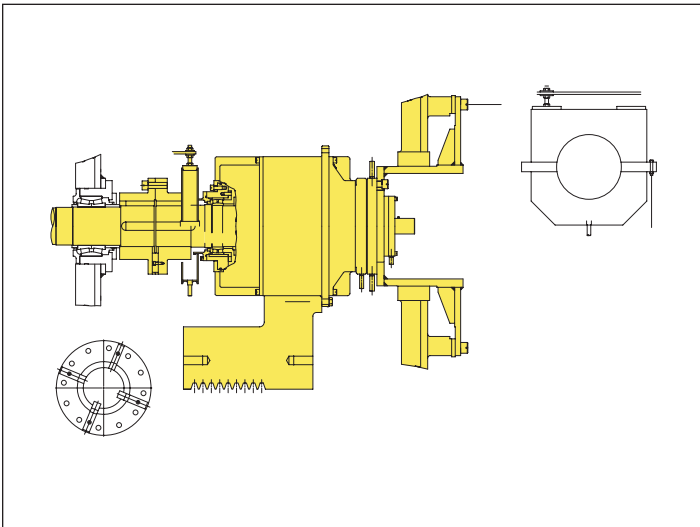

Outrigger Style

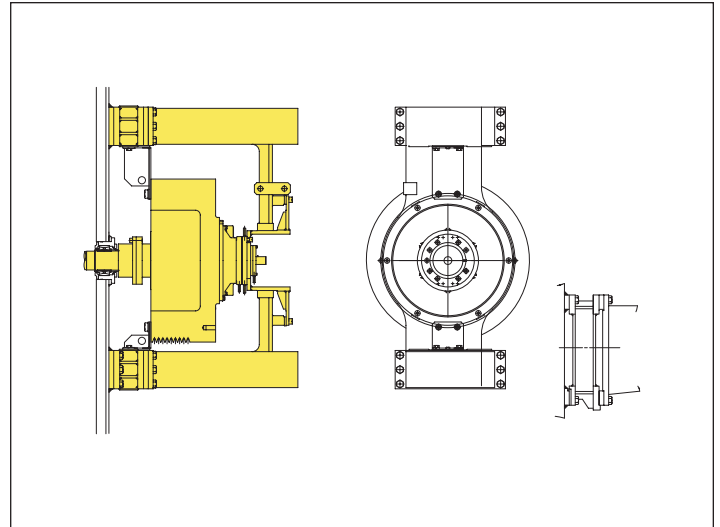

Outrigger Style

Oil Shear Drives For Metal Forming Equipment

Press Pac® 2191 **Hydraulic Actuation / Oil Cooled** **2000 Ton Stamping Press**

Midwest Brake® provided (4) Press Pac 2191 units and circulating oil system for installation on new 2000 ton transfer presses. The presses are run 24 hours per day, 7 days per week at a rate of 7 single strokes per minute.

The Press Pac® 2100 Series Integral Drive System has performed exceptionally well and provided this Tier 1 automotive stamping facility with a significant decrease in maintenance and repair costs.

Application Information:
Press Model: SE4-2000-240-96
Tonnage: 2000
Stroke: 24”
SPM: 10-20
Clutch Torque: 105,000 Lb-ft
Brake Torque: 70,000 Lb-ft

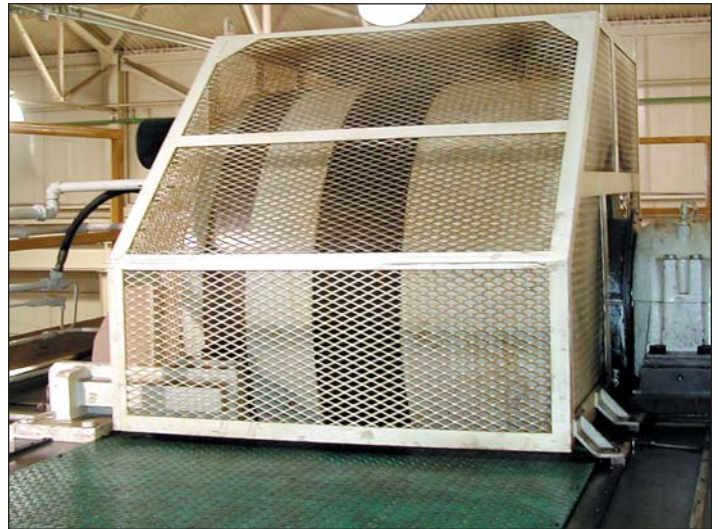

Press Pac® 2165 **Hydraulic Actuation / Oil Cooled** **1250 Ton Stamping Press**

Midwest Brake® provided (2) Press Pac® 2165 units and circulating oil systems for retrofit of (2) 1250 ton stamping presses. Press speed was able to be increased from 15 SPM to 18 SPM due to the advanced design of the Press Pac® Integral Drive System.

Application Information:
Tonnage: 1250
Stroke: 24”
Continuous SPM: 18
Clutch Torque: 65,000 Lb-ft
Brake Torque: 42,000 Lb-ft



Press Pac® 2100 Series Integral Press Drive Systems

Press Pac® 2165 Hydraulic Actuation / Oil Cooled 1250 Ton Stamping Press

Midwest Brake® provided the Press Pac 2165® unit and circulating oil system for retrofit of a 1250 ton stamping press.

Application Information:

Press Model: SE4-1250-120-72

Tonnage: 1250

Stroke: 42"

Continuous SPM: 18

Clutch Torque: 65,000 Lb-ft

Brake Torque: 42,000 Lb-ft

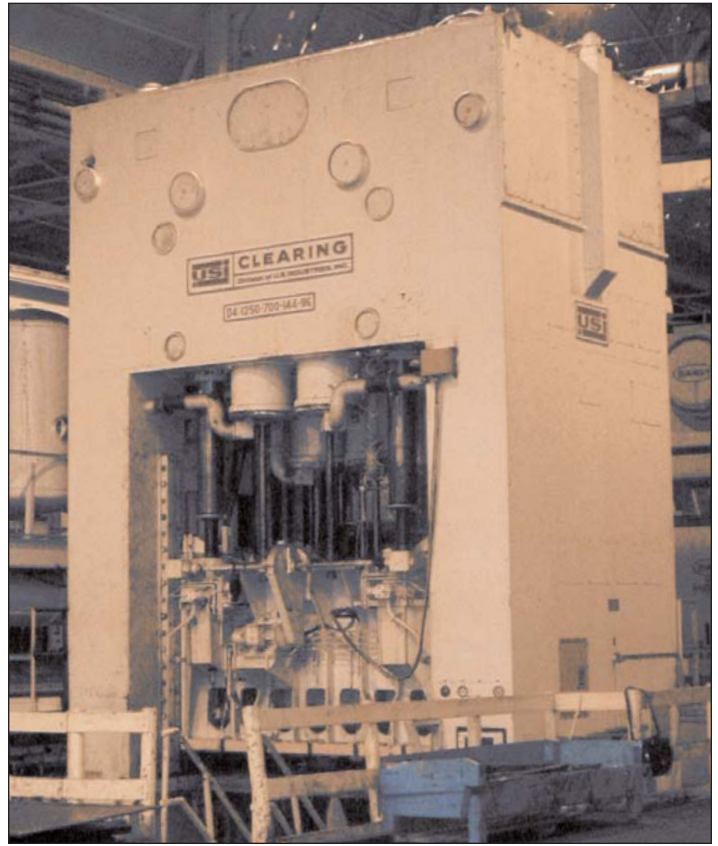

Press Pac® 2131 Hydraulic Actuation / Oil Cooled 800 Ton Stamping Press

Application Information:

Tonnage: 800

Stroke: 20"

Continuous SPM: 30

Clutch Torque = 30,000 Lb-ft

Brake Torque = 15,000 Lb-ft

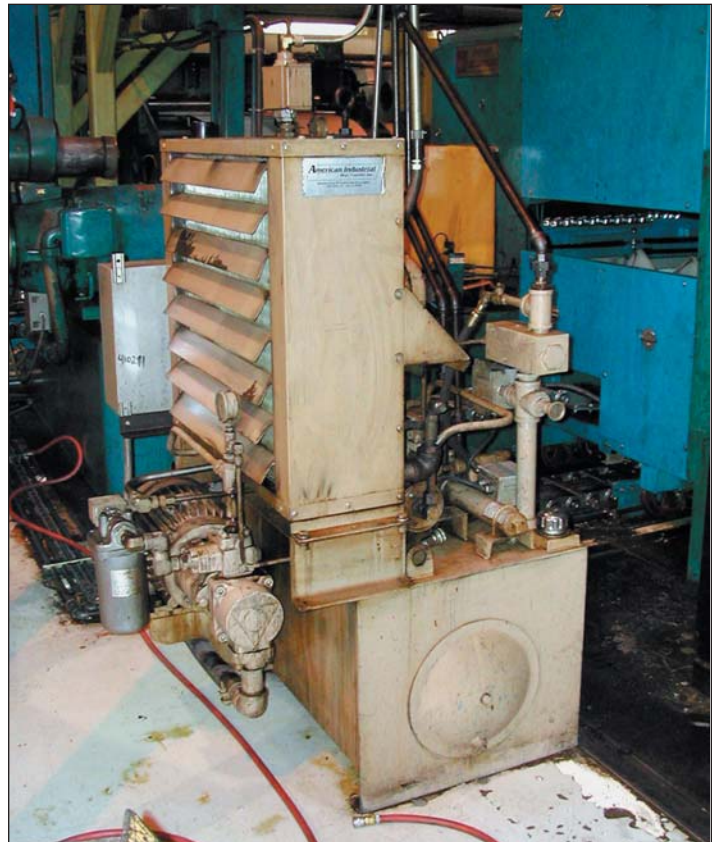

Oil Shear Drives For Metal Forming Equipment

Press Pac® 2195 Hydraulic Actuation / Oil Cooled 3000 Ton Stamping Press

Midwest Brake® provided the Press Pac® 2195 unit and circulating oil system for retrofit of a 3000 ton stamping press for a major automotive manufacturer.

Application Information:

Tonnage: 3000

Stroke: 18"

Continuous SPM: 20

Clutch Torque: 150,000 Lb-ft

Brake Torque: 106,358 Lb-ft



Press Pac® 2141 Hydraulic Actuation / Oil Cooled 1800 Ton Stamping Press

Midwest Brake® provided the Press Pac® 2141 unit and circulating oil system for retrofit of an 1800 ton stamping press.

Application Information:

Tonnage: 1800

Stroke: 16"

Continuous SPM: 15-25

Clutch Torque: 40,000 Lb-ft

Brake Torque: 20,000 Lb-ft



Press Pac® 2100 Series Integral Press Drive Systems

Press Pac® Technical Specifications

Model No.	Clutch Torque		Brake Torque		Oil Flow Rate	Oil Tank Cap	Total Oil Req
	Lb-ft	Nm	Lb-ft	Nm			
2111	10,000	13,589	5,000	6,795	8.2	40	65
2121	20,000	27,178	10,000	13,589	8.2	40	65
2131	30,000	40,767	15,000	20,384	12.5	40	65
2141	40,000	54,356	20,000	27,178	22	40	65
2145	45,489	61,675	29,376	29,829	22	40	65
2161	60,000	81,534	30,000	40,767	22	40	65
2165	65,707	89,087	41,966	56,898	22	40	65
2181	80,000	108,466	53,038	71,910	27	80	110
2191	105,000	135,890	70,555	95,660	27	80	100
2195	150,000	203,830	106,358	144,202	31.5	80	110

Press Pac® Oil Tank Dimensions

Model No.	Tank No.	Length (A)	Width (B)	Height of Tank (C)	Clearance Height (D)
2111	2110	40"	42"	22"	50"
2121	2120/30	40"	42"	22"	50"
2131	2120/30	40"	42"	22"	50"
2141	2140/60	40"	42"	22"	50"
2145	2140/60	40"	42"	22"	50"
2161	2140/60	40"	42"	22"	50"
2165	2140/60	40"	42"	22"	50"
2181	2191/95	70"	35"	22"	60"
2191	2191/95	70"	35"	22"	60"
2195	2191/95	70"	35"	22"	60"

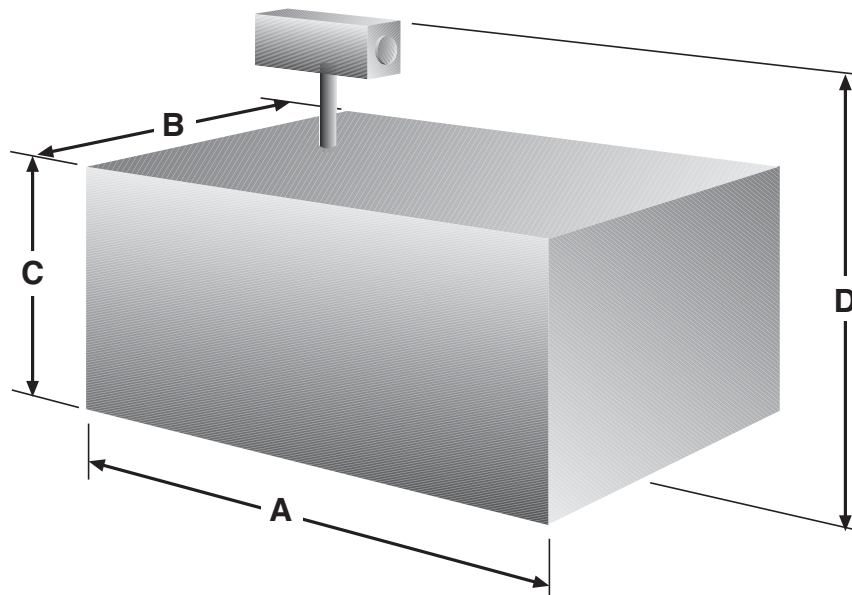

Press Pac® 2100 Series Application Data Sheet

Request for Quotation

Midwest Brake® is able to provide a quotation of the Press Pac® drive system with a few basic, simple pieces of information.

This standard form is to be filled out. Using this information, torque requirements can be calculated and the proper model will be selected.

Please visit our website to download brochures and application data sheets.

Contact Information:

Midwest Brake®
26255 Groesbeck Hwy.
Warren, MI 48089

Phone: 586.775.3000
Fax: 586.775.3040

E-mail:

sales@midwestbrake.com

Website:

www.midwestbrake.com

Company _____

Address _____

City _____ State _____ Zip _____

Contact _____ Title _____

Phone _____ Fax _____

Press Manufacturer* _____ Date of Manufacture _____

Type of Press* _____

- Single Action Top Drive Knuckle Joint
 Double Action Bottom Drive Forging Press

Press Model Number _____

Press Serial Number _____

Tonnage* _____ Rated Tonnage Distance* _____

Stroke of Slide* _____

Continuous Strokes Per Minute* _____

Press Gear Ratio _____

Length of Connection (Pitman Length) _____

Flywheel – Outside Diameter* _____

Sheave – Outside Diameter* _____

Main Motor HP* _____

Main Motor RPM* _____

Other information that may be useful: _____

*Required Information



26255 Groesbeck Hwy.
Warren, MI 48089 U.S.A.
586.775.3000 • 586.775.3040 (Fax)
800.525.4503 (Toll Free)
www.midwestbrake.com
sales@midwestbrake.com (E-mail)

