

WCB 11070

# Installation, Operation and Maintenance of the Airflex® WCB2 Tensioner / Brake



## Warning

Forward this manual to the person responsible for Installation, Operation and Maintenance of the product described herein. Without access to this information, faulty Installation, Operation or Maintenance may result in personal injury or equipment damage.



## Caution:

### Use Only Genuine Airflex® Replacement Parts

The Airflex Division of Eaton Corporation recommends the use of genuine Airflex replacement parts. The use of non-genuine Airflex replacement parts could result in substandard product performance, and may void your Eaton warranty. For optimum performance, contact Airflex:

In the U.S.A. and Canada: (800) 233-5926

Local: (216) 281-2211

Fax: (216) 634-8341

Internet: [www.airflex.com](http://www.airflex.com)

April, 2002

(Revised August 2003)

204182

© Copyright Eaton Corp., 2003. All rights reserved.

Authorized Distributor



26255 Groesbeck Hwy.  
Warren, MI 48089 U.S.A.  
586.775.3000 • 586.775.3040 (Fax)  
sales@midwestbrake.com  
www.midwestbrake.com

Eaton® Airflex® Clutches & Brakes

# Table of Contents

<b>CUTAWAY DRAWINGS</b> . . . . .	<b>3 &amp; 4</b>
<b>1.0 INTRODUCTION</b> . . . . .	<b>5</b>
1.1 Description . . . . .	5
1.2 How it works . . . . .	5
<b>2.0 INSTALLATION</b> . . . . .	<b>6</b>
2.1 Preparation . . . . .	6
2.2 Mounting . . . . .	7
2.3 Air System . . . . .	8
2.4 Coolant System . . . . .	9
<b>3.0 OPERATION</b> . . . . .	<b>12</b>
3.1 Conditions of Operation . . . . .	12
3.2 Pressure and Speed Limits . . . . .	13
3.3 Periodic Maintenance . . . . .	13
<b>4.0 MAINTENANCE</b> . . . . .	<b>14</b>
4.1 Wear Limits . . . . .	14
4.2 Wear Adjustment . . . . .	15
4.3 Disassembly Procedures . . . . .	18
4.4 Friction Material Replacement (Sizes 8 and 14) . . . . .	19
4.5 Friction Material Replacement (Sizes 18,24,36 and 48) . . . . .	19
4.6 Wear Plate replacement . . . . .	20
4.7 Cylinder Seal Replacement . . . . .	23
4.8 Bushing Replacement . . . . .	24
4.9 Assembly Procedures . . . . .	25
4.10 Corrosion Protection . . . . .	26

<b>5.0</b>	<b>ORDERING INFORMATION/TECHNICAL SERVICE . . . . .</b>	<b>26</b>
	Equipment Reference . . . . .	26
<b>6.0</b>	<b>PARTS &amp; KITS . . . . .</b>	<b>28</b>
6.1	Parts (Standard) . . . . .	28
6.2	Parts (Corrosion Resistant) . . . . .	34
<b>7.0</b>	<b>KITS . . . . .</b>	<b>40</b>

<b>Index of Tables</b>		
<b>Table No.</b>	<b>Table Title</b>	<b>Page No.</b>
1	Item Descriptions	3
2	Alignment Requirements	6
3	"A" Dimension on Figure 1 & 2	7
4	Fastener Description and Assembly Torque	7
5	Air Inlet Size	8
6	Coolant Supply Data	10
7	Coolant Pressures	12
8	Maximum Outlet Coolant Temperature	13
9	Maximum Disc Speeds	13
10	Wear Measurement X,Y & Z Gaps	17
11	Wear Plate Fastener Torque	22
12	Inlet and Outlet Port Sizes	22
13	Wear Limits for WCB2 Components (Ref.Figs 1 & 2 and Section 4.0)	27

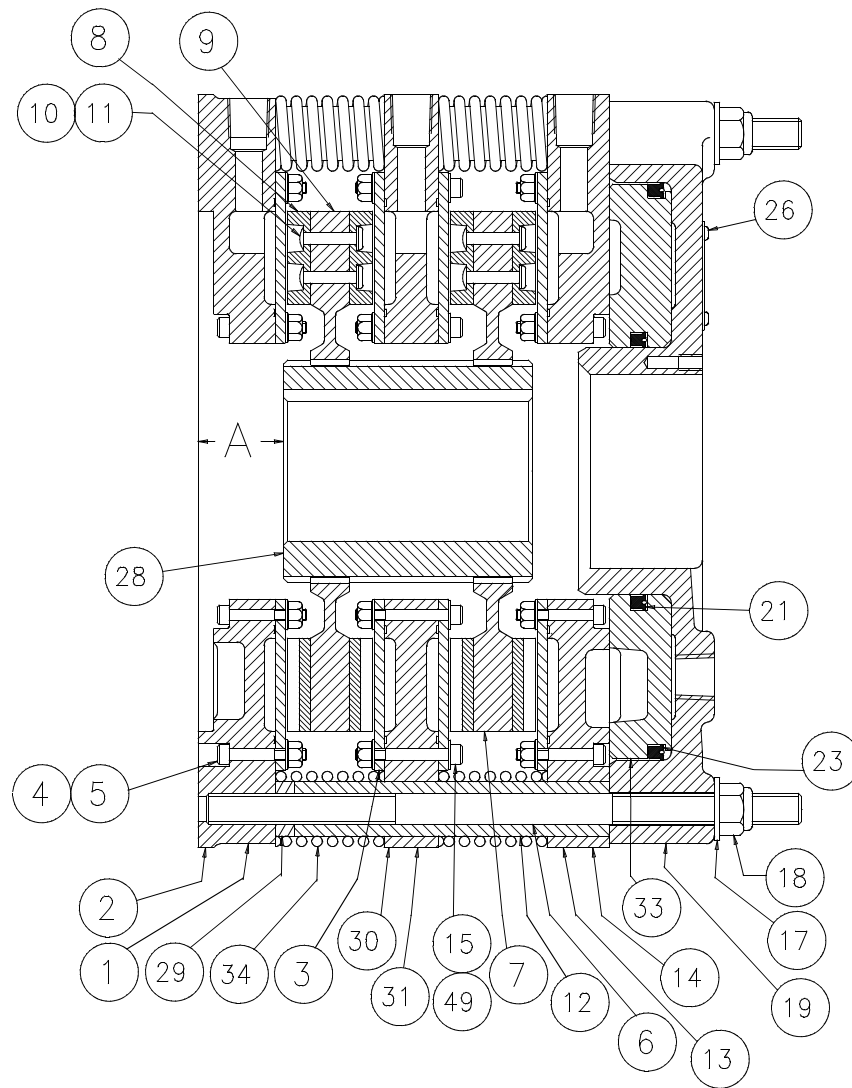

Figure 1

TABLE 1					
Item Description					
Item	Description	Item	Description	Item	Description
1	Mounting Flange S/A	12	Clamp Tube	29	Wear Spacer
2	Mounting Flange	13	Pressure Plate S/A	30	Reaction Plate S/A
3	Wear Plate	14	Pressure Plate	31	Reaction Plate
4	Screw	15	Washer	33	Piston
5	Locknut	17	Flat Washer	34	Release Spring
6	Stud	18	Self Locking Nut	49	Socket Head Screw
7	Friction Disc Assembly	19	Cylinder	50	Inner Support Ring
8	Friction Disc	21	Polypak Seal (Inner)	51	Outer Support Ring
9	Friction Disc Core	23	Polypak Seal (Outer)	57	Flat Head Screw
10	Rivet	28	Gear (Not included in P/L)	105	Pipe Plug
11	Washer				

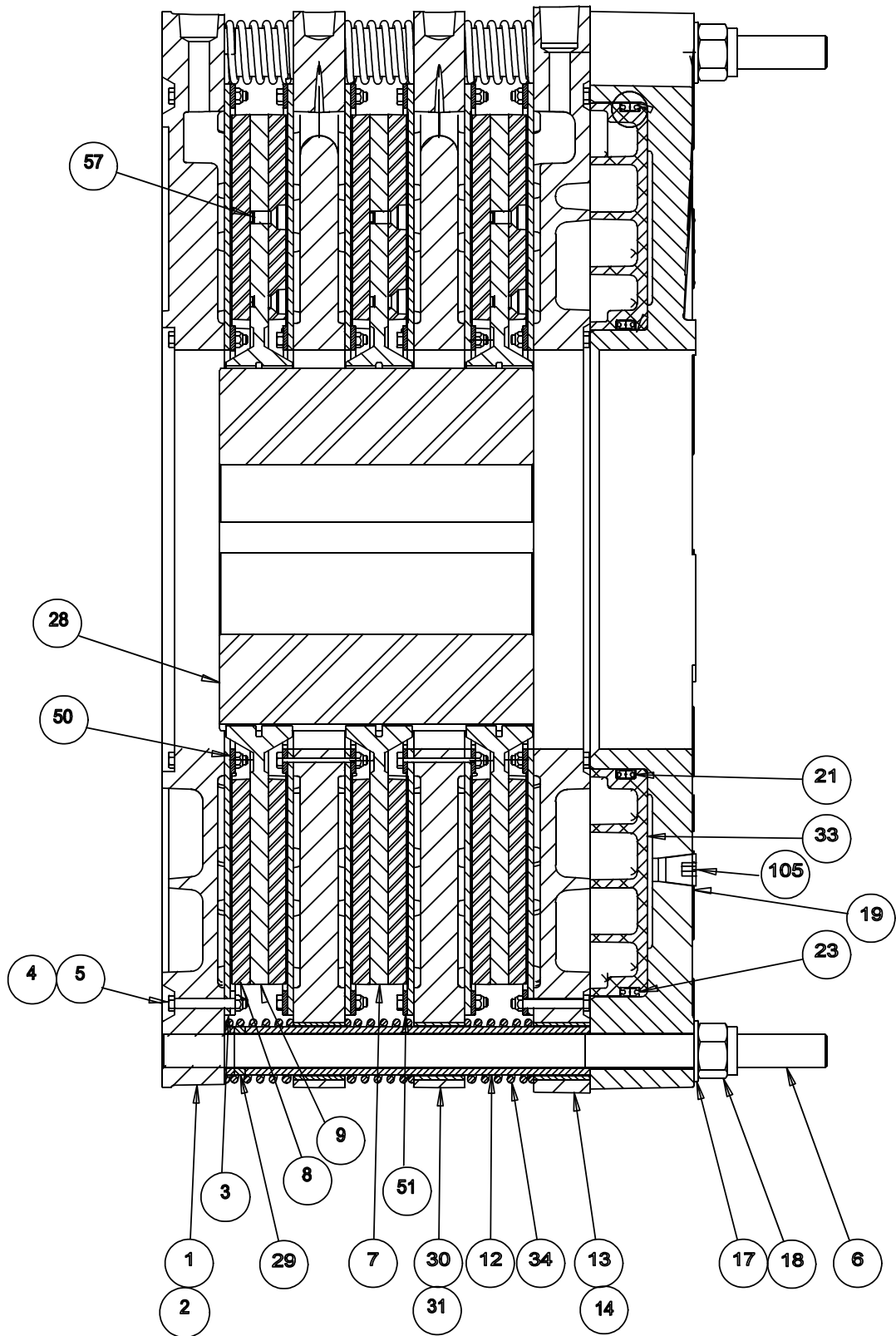



Figure 2

# 1.0 INTRODUCTION

Throughout this manual there are a number of HAZARD WARNINGS that must be read and adhered to in order to prevent possible personal injury and/or damage to the equipment. Three signal words "DANGER", "WARNING", and "CAUTION" are used to indicate the severity of the hazard, and are preceded by the safety alert symbol .



### **Danger:**

**Denotes the most serious injury hazard, and is used when serious injury or death WILL result from misuse or failure to follow specific instructions.**



### **Warning:**



**Used when serious injury or death MAY result from misuse or failure to follow specific instructions.**



### **Caution:**

**Used when injury or product/equipment damage may result from misuse or failure to follow specific instructions.**

It is the responsibility and the duty of all personnel involved in the installation, operation and maintenance of the equipment on which this device is used to fully understand the

 **Danger:**,  **Warning:**, and  **Caution:** procedures by which hazards are to be avoided.

## 1.1 Description

- 1.1.1 The Airflex WCB2 water-cooled tensioner is designed for constant tension applications. It is exceptionally well suited for high inertia stopping and rapid heat dissipation. The design of the WCB2 tensioner permits mid-shaft or end-shaft mounting. The rugged construction ensures long, trouble free service.
- 1.1.2 WCB2 tensioners are available in various sizes and quantities of friction discs. The model number identifies the number of discs and the nominal disc diameter. For example, 324WCB2 indicates three 24" diameter discs.

- 1.1.3 When size, such as 36WCB2, is referred to in this manual, it means that the information given applies to all models using the 36" diameter water-cooled disc assembly; i.e., 236WCB2, 336WCB2, etc.
- 1.1.4 Tensioners can be used with either closed loop or open loop water systems.
- 1.1.5 This manual includes metric equivalents usually shown in brackets (#) following the U.S. measurement system value. Be sure to use the correct value.

## 1.2 How It Works

- 1.2.1 Referring to Figure 1, the gear (28) is mounted on the shaft which is to be stopped and the tensioner assembly is attached to the machine frame or a reaction bracket.

Air pressure is applied through the ports in the cylinder (19) causing the piston (33) and pressure plate assembly (13) to move towards the mounting flange, compressing the release springs. As the applied pressure increases, the friction disc(s) are clamped between the pressure plate and mounting flange, stopping or controlling the shaft the discs are mounted on. Modulation of air pressure then controls applied torque of the tensioner. Multiple disc brakes utilize reaction plates (30) between discs. The release springs (34) assist in disengagement and retraction of the piston, pressure plate, and reaction plates, if applicable. High heat dissipation is accomplished by passing water through a special cavity behind the copper alloy wear plates.

Torque flows through the brake from the shaft to be controlled, through the friction discs, through the pressure plate and reaction plates, through the clamp tubes and studs, to the mounting flange, which is attached to a rigid surface.

## 2.0 INSTALLATION

### **Warning:**

Only qualified maintenance personnel should install, adjust or repair these units. Faulty workmanship will result in unreasonable exposure to hazardous conditions or personal injury.

### **Caution:**

Read these instructions thoroughly and review until you fully understand the installation sequence before proceeding with the work described in this section. Failure to follow these instructions will result in unreasonable exposure to hazardous conditions or personal injury.

### **Caution:**

Do not paint the clamp tubes (12), wear spacers (29), or the release springs (34), as this may hinder the engagement or disengagement of the tensioner.

Note: Some three and four disc units may require support on the cylinder end of the tensioner in certain high torque applications. Contact the factory for specific application information.

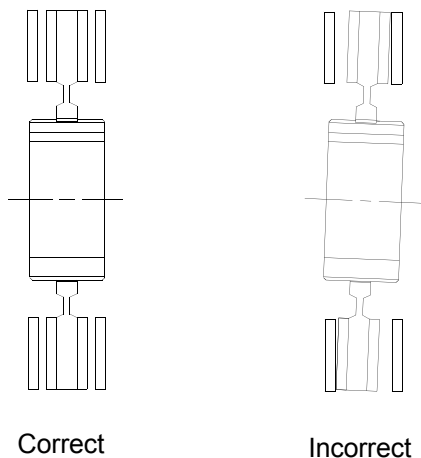

Figure 3

## 2.1 Preparation and Alignment

- 2.1.1 Refer to the appropriate catalog information (available upon request) for appropriate envelope dimensions, mounting register diameters, mounting bolt circles and positions, and stud support bracket recommendations for each specific tensioner.
- 2.1.2 The tensioner reaction member (such as the machine frame) should have a machined register to allow for mounting and alignment control of the tensioner. The mounting surface should be designed to provide full support of the face of the mounting flange (1), preventing deflection during operation.
- 2.1.3 For proper operation and service life, the tensioner reaction member must be aligned to the shaft within the limits shown in Table 2.

### **Caution:**

Proper alignment is necessary to ensure that the friction discs track properly. Improper alignment will result in excessive wear to the friction material and mating surfaces, plus the gear and splined bore of the friction disc assemblies. See Figure 3.

<b>TABLE 2</b>		
<b>Alignment Requirements</b>		
Size	Concentricity (Parallel, TIR) of Shaft and Tensioner Inches (mm)	Perpendicularity (Angular, TIR) of Mounting Flange to Shaft* Inches (mm)
<b>8WCB2</b>	0.0005 (0.13)	0.0005 (0.13)
<b>14WCB2</b>	0.010 (0.25)	0.007 (0.18)
<b>18WCB2</b>	0.010 (0.25)	0.010 (0.25)
<b>24WCB2</b>	0.010 (0.25)	0.012 (0.30)
<b>36WCB2</b>	0.010 (0.25)	0.019 (0.48)
<b>48WCB2</b>	0.010 (0.25)	0.025 (0.64)

\* Perpendicularity measured near the outside diameter of the mounting flange.

Size	Single	Dual	Triple	Quad
<b>8WCB2</b>	1.00 (25.4)	1.38 (35.0)	0.19 (4.8)	N/A
<b>14WCB2</b>	1.06 (26.9)	1.69 (42.9)	1.06 (26.9)	N/A
<b>18WCB2</b>	1.25 (31.8)	1.25 (31.8)	1.25 (31.8)	1.25 (31.8)
<b>24WCB2</b>	1.38 (35.1)	1.38 (35.1)	1.38 (35.1)	1.38 (35.1)
<b>36WCB2</b>	2.36 (59.9)	2.36 (59.9)	2.36 (59.9)	2.36 (59.9)
<b>48WCB2</b>	1.96 (50.0)	1.75 (44.0)	1.75 (44.0)	1.75 (44.0)

2.1.4 Refer to Table 3 for the setup dimension between the tensioner mounting surface and the end of the gear (dimension "A" on Figure 1). Gears should be positioned to ensure that - when the tensioner is mounted - the disc splines will not overhang the end of the gear when components are in both new and worn conditions. The gear is typically bored and keyed for a resulting Class FN2S interference fit for inch shafting and ISO System S7h6 for metric shafting. Contact Airflex Application Engineering for specific recommendations.

## 2.2 Mounting

2.2.1 The WCB2 must be mounted to a clean, rigid surface with hardened flat washers and

screws of the grade, quantity, and size as listed in Table 4. Mounting to a properly aligned, rigid surface *that fully supports the face of the mounting flange* minimizes any deflection during operation and helps to ensure that the friction discs will track properly on the copper wear plates.

Note: To facilitate the mounting process, the friction disc assemblies should be aligned to the gear and centered in the tensioner. With the tensioner positioned with the mounting flange facing down, lower the gear (28) slowly and carefully into the splined bore of the friction disc assemblies (7). Adjust the discs so that they are centered in the tensioner and fit in the gear. Apply and maintain an air pressure of 25PSIG (1.7bar) to the cylinder. This will engage and hold the discs in position during installation. Remove the gear.



### **Danger:**

**Use only the proper number and grade fasteners shown in Table 4. Use of commercial grade (Grade 2) fasteners where Grade 8 fasteners are specified may result in failure of the fasteners and a sudden and drastic reduction in brake torque.**



### **Caution:**

**Water inlets and outlets must be located as close as possible to the 6 o'clock and 12 o'clock positions, respectively. This will help to prevent air pockets in the water cavities, which would allow the tensioner to overheat.**

Item # Description	Specification	8WCB2	14WCB2	18WCB2	24WCB2	36WCB2	48 WCB2
<b>4 Screw &amp; 5 Locknut</b>	Size	#10-24NC	1/4-NC2	5/16-18 NC Gr. 8	5/16-18 NC Gr. 8	3/8-16-NC2 Gr.8	3/8-16-NC2 Gr.8
	Torque, Dry	5 (7)	12 (16)	21 (28)	21 (28)	40 (54)	40 (54)
<b>18 Self Locking Nut</b>	Size	1/2-13NC-3	3/4-10 NC-3	3/4-10 NC-3 Gr. 8	1 1/8-7 NC Gr. 8	1 3/8-6 NC Gr. 8	1 3/8-6 NC Gr. 8
	Torque, Lubed	60 (81)	150 (203)	150 (203)	500 (677)	750 (1016)	750 (1016)
<b>Mounting Screw</b>	Size	1/2-13 NC-2 Gr. 8	5/8-11NC-2 Gr. 8	5/8-11NC-2 Gr. 8	5/8-11NC-2 Gr. 8	1-8 NC Gr. 8	1 3/8-6NC Gr. 5
	Quantity	4	6	10	10	14	14
	Torque, Lubed	70 (95)	150 (203)	150 (203)	150 (203)	660 (895)	1100 (1490)

- 2.2.2 Ensure that the shaft is free of nicks or burrs and the key fits properly in the shaft and gear.
- 2.2.3 Apply a light coat of anti-seizing compound to the shaft and key. Tap the key into the shaft keyway.
- 2.2.4 Heat the gear uniformly to 250°F (121°C) to expand the bore and ease assembly. Press the gear onto the shaft, making sure that the dimension between the gear and the tensioner mounting surface ("A") is maintained. See Figure 1 and Table 3. Allow the gear to cool.
- 2.2.5 Apply a thin coat of MOLUB-ALLOY® OG Heavy - or equivalent - grease to the splines of the gear. For Corrosion Resistant units, use Molub-alloy® 412 ES.



**Caution:**

Excessive lubricant may contaminate friction material, resulting in erratic response or loss of torque.



**Caution:**

The use of anti-seize or bearing greases on the gear splines may result in premature gear and disc spline wear.

- 2.2.6 Pre-fill the grease channel in the friction disc splines (if applicable) with MOLUB-ALLOY® OG Heavy - or equivalent - grease, as shown on Figure 4. Use 412 ES for Corrosion Resistant units.
- 2.2.7 Rig the WCB2 into position and slide it over the gear. Avoid placing lifting straps or cables directly on the release springs (34).

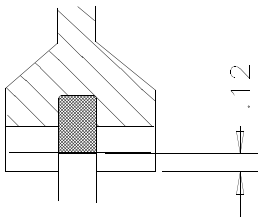

FILL GREASE CHANNEL 360° WITH MOLUB-ALLOY OPEN 412ES GEAR AND CABLE LUBRICANT TO WITHIN .12 OF I.D. AS SHOWN.

Figure 4

- 2.2.8 Attach the mounting flange (1) to the mounting surface using the appropriate fasteners. If applied pressure was used to help position the discs during mounting, exhaust the air pressure prior to tightening the fasteners. Tighten the fasteners to the specified torque value. See Table 4.



**Caution:**

Maximum allowable air pressure in the cylinder (19) is 150psi (10.2 bar).

- 2.2.9 WCB2 tensioners should be covered to protect the unit from dirt, rain, overspray, and other sources of external contamination. In extreme environments the use of a sealed enclosure with internal strip heater is recommended to prevent moisture from collecting on the unit.

## 2.3 Air System



**Warning:**

Maximum allowable air pressure is 150PSIG (10.2bar). Application of pressure exceeding maximum allowable may result in damage to the tensioner.

- 2.3.1 Maximum allowable pressure is 150 psi (10.2 bar).
- 2.3.2 Use only clean, filtered air (a 50 micron filter or better is recommended) which is free of excess moisture.
- 2.3.3 Air inlet sizes are shown in Table 5. Air inlets are located on the face of the cylinder (19). For cylinders with three ports, the lowest port should be located at or near the 6 o'clock position to facilitate purging of moisture that may accumulate in the air system or cylinder.

**TABLE 5**  
Air Inlet Size

Model	Thread Size
8WCB2	3/8"-18 NPT
14WCB2	1/2"-14 NPT
18WCB2	1/2"-14 NPT
24WCB2	1/2"-14 NPT
36WCB2	3/4"-14 NPT
48WCB2	1"-11.5 NPT

2.3.4 All pipes should be free of metal chips, cutting compound and any other foreign matter. Pipe ends should be reamed after cutting to eliminate possible restrictions. For optimum air system response, a minimum number of bends and elbows should be used.

2.3.5 The WCB2 tensioner does not require lubricated air; however associated control valves may. Consult the valve manufacturer for appropriate recommendations.

## 2.4 Coolant System



**Caution:**  
Make sure that the water inlets and outlets are positioned as close as possible to the 6 o'clock and 12 o'clock positions, respectively. This will help to minimize the formation of air pockets in the water cavity during operation, which could contribute to overheating of the tensioner.

2.4.1 Maximum allowable coolant pressure within the water cavity is 40psi for size 36 and 48 WCB2 units and 45psi for all other sizes. See Table 7 for coolant pressure limitations as measured at the inlets and outlets of water jackets. Note that inlet pressures exceeding the maximum allowable static pressures are only permissible under dynamic flow conditions, provided that the average pressure between the inlet and outlet does not exceed the maximum allowable pressure stated above. The use of an accumulator or pressure relief valve may be desirable to reduce the effect of pressure spikes in the coolant system during operation.



**Caution:**  
High outlet pressures or surges exceeding maximum allowable may result in damage to the tensioner.



**Caution:**  
Maximum allowable water pressure is dependent upon tensioner size and specific application requirements.



**Caution:**  
Inlet pressures exceeding the maximum allowable average pressure are only permissible when the outlet pressures are at or below the limits listed in Table 7.

2.4.2 The coolant supply and discharge hose, pipe and fitting sizes, along with minimum flow rates for the tensioner rated horsepower, are listed in Table 6.

2.4.3 Coolant supply connections to the tensioner should provide a parallel flow through each section of the tensioner. Series flow is not recommended, as it can lead to overheating of the tensioner.

2.4.4 Inlet and outlet coolant manifolds must be provided. Manifolds should be constructed to allow for even flow through all ports. On sizes 18" and larger, two hoses can be routed to the reaction plates (30) to assist with balancing the flow to each wear plate.

Note: Reaction plates (30) in WCB2 sizes 18" and larger typically have two inlet and two outlet ports to assist with obtaining balanced flow to each cooling chamber. In the event that a multiple disc tensioner includes an older style reaction plate with only one inlet and one outlet port, water flow should be restricted at the inlets to the pressure plate (13) and mounting flange (1) to allow for equally proportional heat dissipation at each cooling cavity. See Figure 5.

2.4.5 Use flexible connecting hose to each tensioner coolant section to allow axial travel of the pressure plate, reaction plate, and end plate during tensioner operation without restricting the movement of components. When determining hose lengths, consideration should be given to movement and location of the pressure plate and reaction plate as friction material wears. Hose lengths running between the manifolds and the inlet or outlet ports should be equal in length, if possible. Reductions in the recommended line diameter should be avoided to prevent excessive line pressures.

**TABLE 6**  
**Coolant Supply Data**

No. of Discs	Disc Size	Thermal Rating <sup>1</sup> HP (kW)	Water Inlet and Outlet Pipe Size  (Minimum piping I.D.)	Min. Flow Rate <sup>2</sup> GPM (dm <sup>3</sup> /min) 100% Water	Min. Flow Rate <sup>2</sup> GPM (dm <sup>3</sup> /min) 70% Water, 30% Ethylene Glycol by Vol.	Min. Flow Rate <sup>2</sup> GPM (dm <sup>3</sup> /min) 60% Water, 40% Ethylene Glycol by Vol.	Min. Flow Rate <sup>2</sup> GPM (dm <sup>3</sup> /min) 50% Water, 50% Ethylene Glycol by Vol.
1	8"	30 (22.4)	3/8"-18 NPT  (3/8")	3 (11.4)	3.5 (13.4)	3.9 (14.7)	4.5 (17.0)
2		60 (44.7)		6 (22.7)	7 (26.8)	7.8 (29.4)	9 (33.9)
3		90 (67.1)		9 (34.2)	10.5 (40.2)	11.7 (44.1)	13.5 (50.9)
1	14"	60 (44.7)	1/2"-14 NPT  (1/2")	6 (22.7)	7 (26.8)	7.8 (29.4)	9 (33.9)
2		120 (89.4)		12 (45.4)	14 (53.6)	15.6 (58.8)	18 (67.9)
3		180 (134.4)		18 (68.4)	21 (80.4)	23.4 (88.2)	27 (101.8)
1	18"	120 (89.4)	1/2"-14 NPT  (1/2")	12 (45.4)	14 (53.6)	15.6 (58.8)	18 (67.9)
2		240 (179)		24 (91)	28 (106)	31(117)	36 (136)
3		360 (268)		36 (136)	42 (162)	47 (177)	54 (204)
4		480 (358)		48 (182)	56 (212)	62 (234)	72 (272)
1	24"	270 (201)	3/4"-14 NPT  (3/4")	27 (102)	32 (121)	35 (132)	40 (151)
2		540 (402)		54 (204)	64 (242)	70 (265)	80 (303)
3		810 (603)		81(305)	96 (361)	105 (395)	120 (451)
4		1080 (805)		108 (406)	128 (481)	140 (526)	160 (602)
1	36"	650 (485)	1 1/4"-11 NPT  (1")	65 (246)	76 (288)	84 (318)	98 (371)
2		1300 (969)		130 (489)	152 (572)	168 (632)	196 (737)
3		1950 (1454)		195 (738)	228 (863)	253 (958)	294 (1113)
4		2600 (1937)		260 (978)	304 (1143)	336 (1263)	392 (1474)
1	48"	1300 (969)	1 1/4"-11 NPT  (1 1/4")	130 (489)	152 (572)	168 (632)	196 (737)
2		2600 (1937)		260 (978)	304 (1143)	336 (1263)	392 (1474)
3		3900 (2906)		390 (1467)	456 (1715)	504 (1895)	588 (2211)
4		5200 (3874)		520 (1956)	608 (2286)	672 (2526)	784 (2948)
1 - Thermal rating based on a 70°F (21°C) water inlet temperature and a 50°F (28°C) temperature rise between inlet and outlet.							
2 - Flow rate is based on requirement of 1 U.S. GPM per 10 HP (1.97 kW per dm <sup>3</sup> /min) thermal dissipation.							

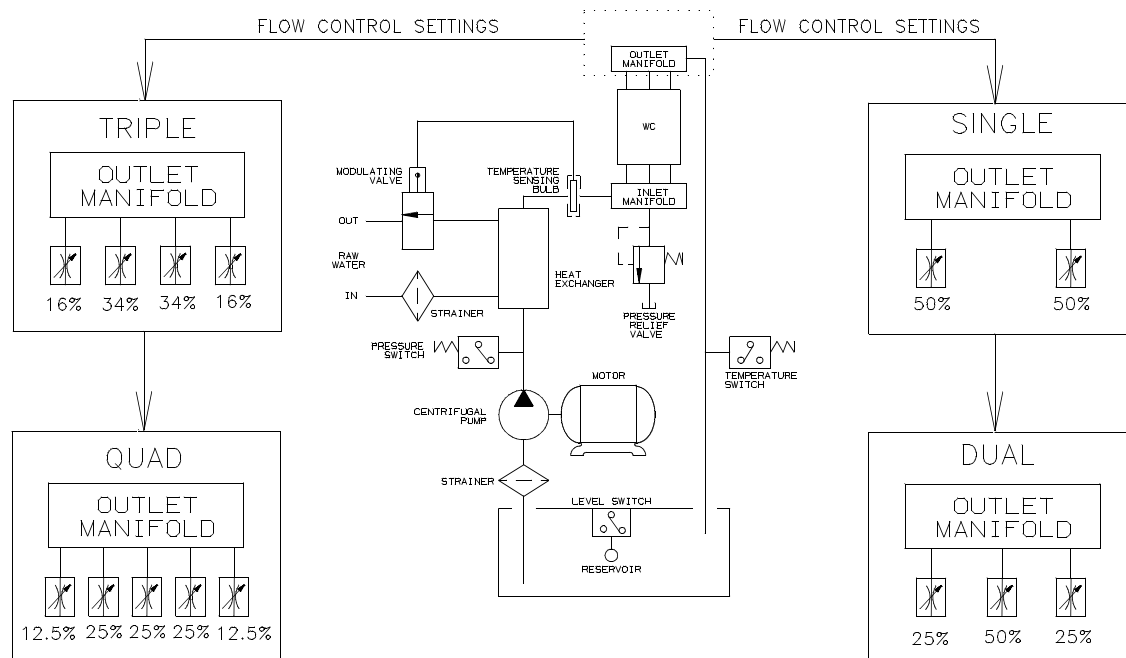

Figure 5

2.4.6 Avoid the use of sharp bends and elbows that will restrict water flow. Loops and bends in the lines may create air pockets, which substantially reduce the flow of coolant and can contribute to overheating.

2.4.7 Coolant and coolant supply lines should be free of foreign material (a 500 micron water filter is recommended). In the event that contaminated water is used as a coolant (not generally recommended), use of a multi-stage filter / strainer may be desirable to avoid the need for frequent cleaning of fine mesh filters.

2.4.8 Figure 5 illustrates a typical closed loop liquid to liquid coolant system. The heat exchanger and temperature control would be replaced with a radiator, fan and motor in a liquid to air system.

2.4.9 The coolant supply temperature at the inlet should be 100°F (38°C) or lower. The coolant outlet temperature should not exceed the values given in Table 8. However, *in no event* should there be more than a 50°F (28°C) temperature rise between inlet and outlet. See Table 8 for maximum allowable outlet coolant temperature with various water/ethylene glycol mixtures and other cooling media.

#### 2.4.10 Open Loop Systems

For efficient operation of the WCB2, an adequate supply of filtered fresh water is required. (See 2.4.1 - 2.4.2). Excessive water

hardness promotes the formation of scale deposits, which, in time, will affect the service life of the WCB2 unit. Water of high acidity or high in corrosive salts may cause electrolytic corrosion between the dissimilar metals used in the water cavities. Water treatment should be considered if the properties of the water exceed the following:

Equivalent calcium carbonate content hardness): Maximum 100 p.p.m.

pH value: 7.0 to 9.0.



#### Caution:

**Open loop systems should be thoroughly flushed with clean fresh water after operation to reduce the corrosive effects of contaminants on internal components.**

#### 2.4.11 Closed Loop Systems

For efficient operation of the WCB2 in a closed loop system, ethylene glycol coolant conforming to SAE Standard J1034 should be used. For preparation of the proper concentration of a water/ethylene glycol mixture, use make-up water which is low in corrosive ions such as chlorides and sulfates.

Recommended pH value of the water/ethylene glycol mixture: 7.5. to 10.5.

**TABLE 7**

**Coolant Pressures, psi (bar)**

Size	Maximum Static	Maximum Inlet*	Maximum Outlet*	Minimum Outlet	Maximum Delta (In-Out)	Minimum Delta (In-Out)	Maximum Average	Minimum Average
<b>8WCB2</b>	45 (3,1)	65 (4,5)	25 (1,7)	0	65 (4,5)	40 (2,7)	45 (3,1)	32.5 (2,2)
<b>14WCB2</b>	45 (3,1)	65 (4,5)	25 (1,7)	0	65 (4,5)	40 (2,7)	45 (3,1)	32.5 (2,2)
<b>18WCB2</b>	45 (3,1)	65 (4,5)	25 (1,7)	0	65 (4,5)	40 (2,7)	45 (3,1)	32.5 (2,2)
<b>24WCB2</b>	45 (3,1)	65 (4,5)	25 (1,7)	0	65 (4,5)	40 (2,7)	45 (3,1)	32.5 (2,2)
<b>36WCB2</b>	40 (2,7)	60 (4,1)	20 (1,4)	0	60 (4,1)	40 (2,7)	40 (2,7)	30 (2,06)
<b>48WCB2</b>	40 (2,7)	60 (4,1)	20 (1,4)	0	60 (4,1)	40 (2,7)	40 (2,7)	30 (2,06)

\* Under dynamic flow conditions.

NOTE: Above ratings for tensioning / winding type applications. For high cyclic applications, consult the factory.

### 3.0 OPERATION

#### 3.1 Conditions of Operation

The following Hazard Warnings are to be followed for proper WCB2 functioning:

 **Warning:**

Friction lining must be worn-in to achieve product torque rating. For new installations or after repair, a minimum wear-in period for the friction couple of four hours at 50% of the rated horse-power is recommended to achieve rated torque. Verify proper operation before putting the product into service.

 **Warning:**

Protective means must be used to prevent oil, grease, dirt or coolant from coming into contact with the surfaces of the friction discs (8), or the wear plates (3). Oil or grease on these parts will significantly reduce the torque capacity of the unit. Dirt or coolant will produce erratic torque. Do not risk personal injury or damage to the equipment.

 **Warning:**

Maximum free wheeling speed must not exceed the speeds listed in Table 9. Exposure to speeds in excess of these values may cause the friction discs (8) to burst and result in extensive damage to the tensioner and/or cause personal injury.

 **Caution:**

For proper cooling of the WCB2 tensioner, it is required that the coolant inlet be located as close as possible to the 6 o'clock position and the outlet be located near the 12 o'clock position. This will help to assure that all coolant cavities are water-filled to help avoid overheating.

 **Caution:**

For operation in subfreezing temperatures, ethylene glycol antifreeze must be added to the water. The antifreeze content of the mixture is critical and should not exceed 50% by volume. Excessive amounts of antifreeze will reduce cooling capacity and can cause coolant leakage due to overheating. Refer to Table 8.

 **Caution:**

Maximum ambient temperature is 110°F (43°C). Minimum ambient temperature for closed loop systems using ethylene glycol antifreeze is 0°F (-18°C). For open loop systems using water as a coolant, the minimum ambient temperature is 45°F (7°C).

## 3.2 Pressure and Speed Limits

- 3.2.1 Maximum applied air pressure is 150 PSIG (10.2 bar).
- 3.2.2 Maximum coolant pressure allowable within the water cavities is 40psi (2,7 bar) for size 36 and 48 WCB2 units and 45psi (3,1 bar) for all other sizes. The use of an accumulator or pressure relief valve may be desirable to reduce the effect of pressure spikes in the coolant system during operation.



### Warning:

**Maximum allowable water pressure is dependent upon tensioner size. Water piping elevations, restrictions in outlet piping or pressure surges may cause pressures that exceed the maximum allowable, resulting in damage to the tensioner.**

- 3.2.3 Maximum slip speeds and free wheeling disc speeds are shown in Table 9.



### Caution:

**Excessive slip speeds will result in rapid friction material wear. For good life of wear components, the operating values in Table 9 should not be exceeded.**

## 3.3 Periodic Maintenance

- 3.3.1 As the friction material wears, adjustment of the tensioner may be required to keep pistons within the proper stroke range. See Section 4.0 for wear measurement, adjustment procedures and component wear limits.

<b>Water/Ethylene Glycol Mixture % by Volume</b>	<b>Maximum Outlet Coolant Temperature °F ( °C )</b>
100/0	150 (66)
70/30	165 (74)
60/40	165 (74)
50/50	170 (77)

- 3.3.2 Periodically check for external air leakage in the area of the piston seals (21) (23). For replacement, refer to procedures in Section 4.0, Maintenance.
- 3.3.3 Moisture that may accumulate in the cylinder can be purged. With air pressure exhausted from the cylinder, remove the pipe plug (105) at the 6 o'clock position on the cylinder, and apply low air pressure to assist in expelling any excess moisture. After draining the cylinder, reinstall the pipe plug, applying a pipe thread sealant on the threads prior to installation.



### Caution:

**Applied air pressure greater than 10psi should not be used when draining the cylinder. Use adequate shielding to avoid contact with direct spray from moisture being purged from the cylinder.**

- 3.3.4 Periodically observe the rotating discs while the tensioner is fully released. Dragging discs may be caused by wear or contamination of the gear or disc splines, lack of spline lubrication, disc imbalance, warped discs, or misalignment. Correct as required.
- 3.3.5 Pneumatic and electrical control interlocks should be periodically checked for proper settings and operation.
- 3.3.6 If leakage or blockage of any watercooled chamber is suspected, a static or dynamic test may be performed as follows:

<b>Size</b>	<b>Max. Slip Speed RPM</b>	<b>Max. Free Wheeling Speed RPM</b>
<b>8WCB2</b>	2150	3400
<b>14WCB2</b>	1260	2100
<b>18WCSB</b>	955	1600
<b>24WCSB</b>	715	1200
<b>36WCSB</b>	475	700
<b>48WCSB</b>	360	600

### 3.3.6.1 **Static Pressure Test:**

- a) Release the tensioner by exhausting the air pressure from the cylinder.



**Ensure that the machinery will remain in a safe position prior to releasing the brake.**

- b) Bleed all air from within the coolant cavity. Air bleeding must be accomplished by running coolant through the cavity with the tensioner secured in its proper operating position.

Note: Avoid contaminating the friction material with coolant or water.



**Contamination of the friction material could result in erratic or loss of torque.**

- c) After the air has been removed, install a pipe plug(s) in the outlet(s) and apply maximum allowable coolant pressure measured at the inlet to the water cavity. Maximum allowable is 40 PSIG (2.7 bar) for size 36" and 48" units, and 45 PSIG (3.0 bar) for all other sizes. Maintain this pressure for 30 minutes. Check for leakage at O.D. and I.D. sealing areas.

### 3.3.6.2 **Dynamic Flow Test:**

- a) Dynamic flow testing of the tensioner should be conducted at the required flow rate for the rated HP dissipation and coolant quality, as given in Table 6. Inlet and outlet pressures for the appropriate tensioner size as listed in Table 7 should not to be exceeded.
- b) There should be no restrictions on the outlet side of the brake to cause any back pressure to the unit. Coolant inlet and outlet sizes are listed in Table 6. Full size hoses and piping should be used. Check for low flow and/or leakage at the O.D. and I.D. seal areas.

## 4.0 MAINTENANCE



**Before performing any maintenance work on the WCB2 tensioner, make sure that the machinery will remain in a safe position. Failure to do so could result in serious injury or possibly death.**



**Only qualified maintenance personnel should install, adjust or repair the WCB2 units. Faulty workmanship will result in unreasonable exposure to hazardous conditions or personal injury.**



**Read these instructions thoroughly and review until you fully understand the parts replacement steps before proceeding with the work described in this section. Failure to follow these instructions can result in unreasonable exposure to hazardous conditions or personal injury.**

## 4.1 Wear Limits



**Periodically examine the tensioner for wear of friction linings and wear plates. Failure to perform this examination periodically may result in excessive wear to components, improper operation or a significant reduction in torque, and may result in personal injury and/or damage to the machinery.**

- 4.1.1 Wear limits for the WCB2 components are shown in Table 13. If any wear limit has been reached or exceeded, that component must be repaired or replaced.

## 4.2 Wear Adjustment



**If a wear adjustment is not made when required, the brake torque may deteriorate to the point where the equipment will not stop properly.**

### 4.2.1 Determining Wear

The friction material must be replaced when worn to the bottom of the groove of the friction lining - as shown on Figure 6 (or O.D. "step" for size 48") - or any "Y" or "Z" dimension exceeds the limits shown on Table 10. On multi-disc units, a wear adjustment is required when the "X" dimension has been reached and the friction discs or "Y" or "Z" dimension(s) are NOT worn to their limits.

#### 4.2.1.1 Single Disc Units

Apply approximately 25 PSIG (1.7 bar) air pressure to the cylinder to engage the tensioner. Measure the "X" gap between the cylinder (19) and the pressure plate (13) or the gap "Y" between the pressure plate (13) and the mounting flange (2) as shown in Figure 7. If either gap exceeds the limits shown in Table 10, the friction discs and/or wear plates must be inspected to ensure that the wear limits listed in Table 14 have not been exceeded.

#### 4.2.1.2 Multi-disc Units

Apply approximately 25 PSIG (1.7 bar) air pressure to the cylinder to engage the tensioner. Measure the gap "X" between the cylinder (19) and the pressure plate (13) to determine if adjustment may be required.

Measure the "Y" gap between the pressure plate (13) and the reaction plate (31), the "Y" gap between the reaction plate (31) and the mounting flange (2), and the "Z" gap between the reaction plates (31) as shown in Figures 8, 9 and 10.

If the "X<sub>worn</sub>" dimension has been reached or exceeded and the "Y" or "Z" dimensions have not reached the limits shown in Table 10 **AND** none of the friction discs are worn to the bottom of the wear groove / step, wear adjustment is required. It is also recommended that wear plates be inspected to ensure that the wear limits listed in Table 13 have not been exceeded.



#### **Warning:**

**If wear adjustment is not made, the piston may extend out of the cylinder beyond an acceptable operating range, resulting in loss of torque and/or seal damage.**

If the "Y" or "Z" dimensions have been reached or any of the friction discs are worn to the bottom of the wear groove (or step), the tensioner should be taken out of service and rebuilt with new components as required.

#### 4.2.2 Adjustment Procedure

Wear adjustment can be conducted without full disassembly of the WCB2 tensioner. The wear adjustment spacers are slotted to allow for easy removal with a chisel.

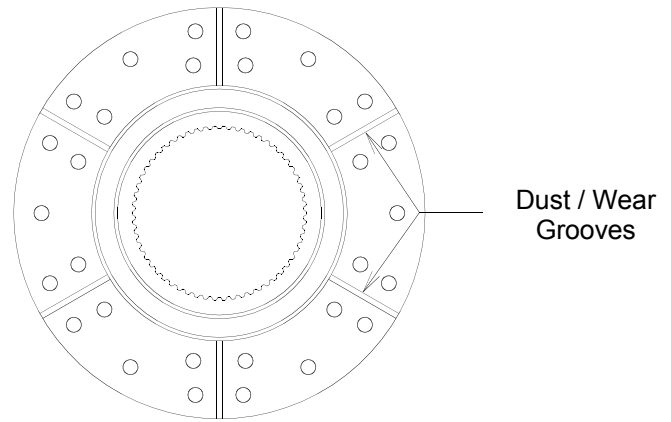

Figure 6



#### **Warning:**

**Before performing any maintenance work on the WCB2 unit, make sure that the machinery will remain in a safe position. Failure to do so could result in serious injury or possibly death.**

Note: It may be necessary to disconnect air and water supply lines to prevent damage to the hoses and binding of components during the adjustment procedure.

- 4.2.2.1 Wear spacers should be removed in complete sets only (one from each stud location). Mark the spacers to be removed to avoid confusion during removal.



#### **Warning:**

**Removal of spacers in quantities other than complete sets (layers) will result in severe damage to WCB2 components during re-assembly, and could cause the brake to not function properly.**

- 4.2.2.2 If so equipped, remove the support bracket from the cylinder (19) end of the unit.
- 4.2.2.3 Loosen the locknuts (18) evenly (ONE TURN AT A TIME) and in an alternating (cross wise) pattern to prevent binding of the cylinder on the studs. Continue to loosen the locknuts until the force of the release springs is relieved, allowing for access to the wear spacers. It may be necessary to push the pressure plate and reaction plate(s) away from the mounting flange so that the release springs can be moved to gain access to the wear spacers.

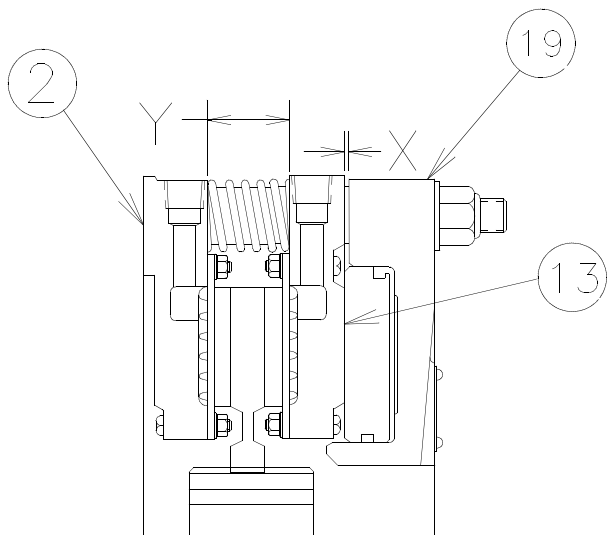

Figure 7

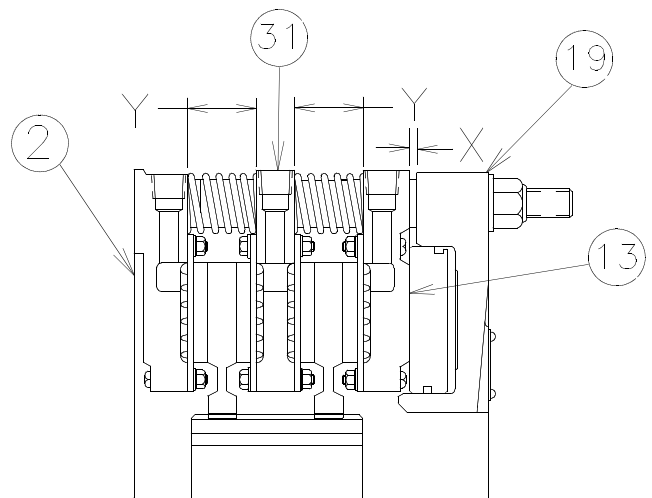

Figure 8

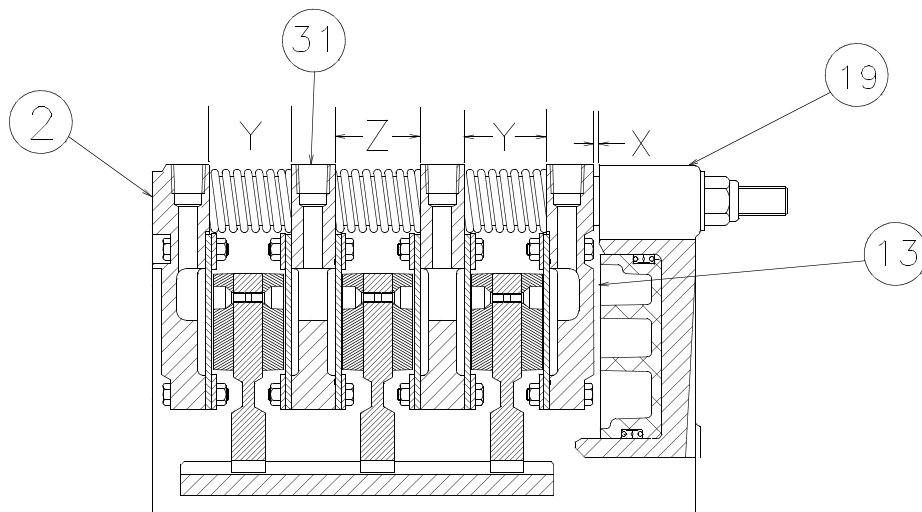

Figure 9

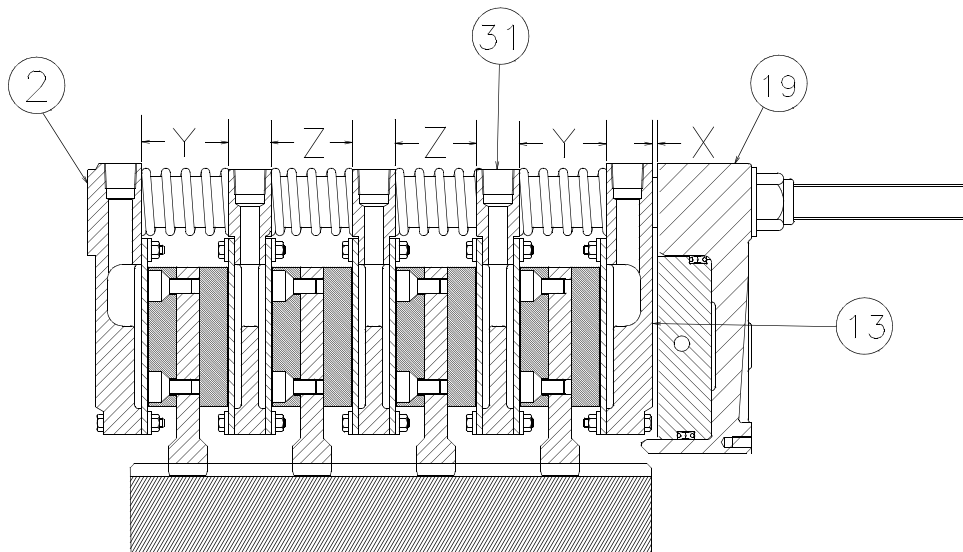

Figure 10

**TABLE 10****X, Y, & Z Gaps - Inches**

<b>Disc Size Inches</b>	<b>No. of Discs</b>	<b>X new</b>	<b>X Max (Adjustment)</b>	<b>Y New</b>	<b>Y Min</b>	<b>Z New</b>	<b>Z Min</b>
8	1	0.06	0.44	1.69	1.31	---	---
	2	0.12	0.50	1.69	1.31	---	---
	3	0.18	0.56	1.69	1.31	1.69	1.31
14	1	0.07	0.45	1.84	1.46	---	---
	2	0.14	0.52	1.84	1.46	---	---
	3	0.21	0.59	1.84	1.46	1.84	1.46
18	1	0.08	0.58	1.95	1.45	---	---
	2	0.16	0.66	1.95	1.45	---	---
	3	0.24	0.74	1.95	1.45	2.04	1.75
	4	0.32	0.82	1.95	1.45	2.04	1.75
24	1	0.09	0.59	2.92	2.42	---	---
	2	0.18	0.68	2.92	2.25	---	---
	3	0.27	0.77	2.92	2.25	2.58	2.08
	4	0.36	0.86	2.92	2.25	2.58	2.08
36	1	0.12	0.42	2.75	2.31	---	---
	2	0.24	0.42	2.75	2.31	---	---
	3	0.36	0.42	2.75	2.31	2.75	2.31
	4	0.48	0.42	2.75	2.31	2.75	2.31
48	1	0.15	0.57	3.37	2.95	---	---
	2	0.30	0.72	3.37	2.95	---	---
	3	0.45	0.87	3.37	2.95	3.37	2.95
	4	0.60	1.02	3.37	2.95	3.37	2.95

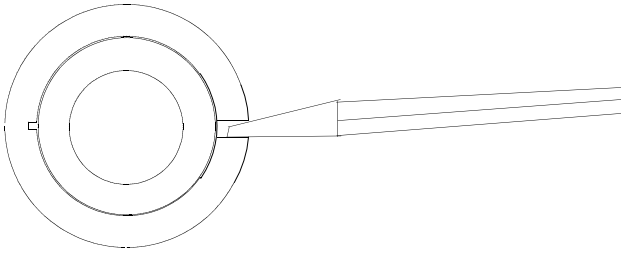

Figure 11

- 4.2.2.4 Wear spacers are slotted to allow for in-place removal. Using a narrow chisel wedged into the slot in the spacer, as shown in Figure 11, pry the wear spacer until it fractures and is clear to be removed from the stud. Repeat for the remaining spacers in the set that is to be removed (one spacer from each stud location).



**Warning:**

**Be sure to collect *all* wear spacers when removed. Spacers lodging in between tensioner components could prevent the tensioner from properly engaging or releasing.**

- 4.2.2.5 While supporting the weight of the cylinder/piston assembly, tighten the locknuts (18) **ONE TURN AT A TIME** and in a crosswise pattern, until the cylinder is seated firmly against the clamp tubes. Torque the locknuts to the appropriate value. See Table 4.



**Caution:**

**The locknuts (18) must be tightened gradually and evenly to prevent damage to the brake components.**

- 4.2.2.6 Reinstall the support bracket if required.
- 4.2.2.7 Restore any piping or covers removed prior to operating the tensioner.

### 4.3 Disassembly Procedures



**Warning:**

**Ensure that the machinery is and will remain in a safe position prior to loosening fasteners or removing the tensioner.**

- 4.3.1 Disconnect the air supply lines and water lines from the tensioner.
- 4.3.2 Remove the fasteners that secure the tensioner (and support bracket, if applicable) to the mounting structure.
- 4.3.3 Using soft slings, rig the tensioner and slide the WCB2 off of the gear. Avoid placing slings or straps directly on the release springs (34).
- 4.3.4 Transport the tensioner to a clean working area and position the unit on a flat surface with the mounting flange (1) facing down.
- 4.3.5 If the gear (28) requires replacement, remove it from the shaft with a portable jack, using the threaded holes in the end of the gear for puller holes. Heating may be required to ease removal. Replace the gear and install per Section 2.2.
- 4.3.6 Match-mark the mounting flange (1), reaction plates (30), pressure plate (13) and cylinder (19) to one another prior to disassembly to adequately show the proper orientation of components and various ports to one another.
- 4.3.7 Loosen the locknuts (18) **ONE TURN AT A TIME** and in sequence until the release spring force is relieved.
- 4.3.8 Lift the cylinder and piston off of the studs as an assembly. Set the assembly aside on a clean, level area, making sure to avoid damaging the face of the piston.
- 4.3.9 Continue removing the remaining components if required.
- 4.3.10 Inspect all components using the wear limits in Table 14 as a reference.
- 4.3.11 For friction lining replacement refer to Section 4.4 or 4.5.
- 4.3.12 For wear plate replacement refer to Section 4.6.
- 4.3.13 Refer to Section 4.7 to replace seals.
- 4.3.14 Assemble the tensioner per Section 4.9.

## 4.4 Friction Material Replacement (Sizes 8 and 14)

Note: When replacing friction material, it is recommended that the mating wear surface be replaced or machined flat to ensure good contact between the mating surfaces. See Table 14 for wear limits.

- 4.4.1 Friction disc cores may be relined with new friction material per the following instructions. Refer to Section 6.0 for the appropriate friction disc replacement kit part number.



**Caution:**  
Use only genuine, Airflex friction material. Use of material not of Airflex origin may result in unpredictable brake performance and/or excessive wear of the brake components.

- 4.4.2 Drill out the old rivets and discard the old friction discs.
- 4.4.3 Clean and de-burr the friction disc cores. If rivet holes in the core are elongated or damaged, the disc core should be repaired or replaced.
- 4.4.4 Position the friction discs on both sides of the disc core and align the rivet holes, using several rivets as a guide.

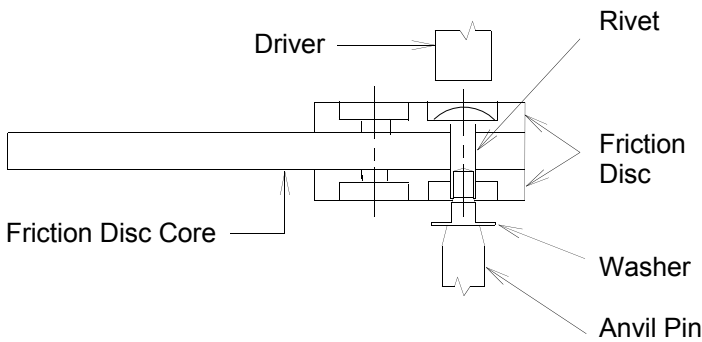

Figure 12

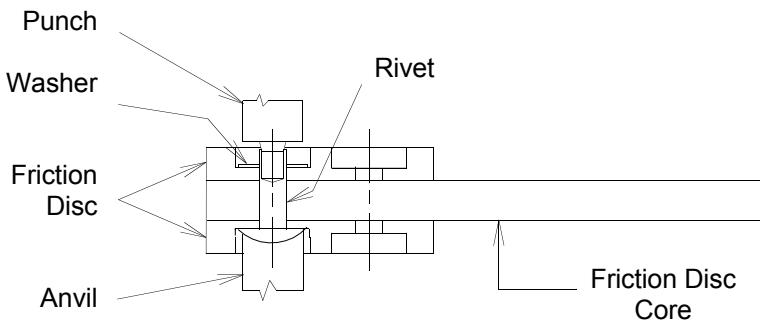

Figure 13



**Caution:**  
Manual setting of the rivets using a punch very frequently results in splitting of the clinched end of the rivet. When this occurs, the rivet will ultimately fail in service due to fatigue. It is therefore recommended that rivets be set using an automatic rivet setting machine if possible.

- 4.4.5 Insert a rivet through any hole and set using a washer on the clinched end of the rivet. Figure 12 illustrates machine setting and Figure 13 illustrates setting the rivet manually. When setting manually, use an arbor press and keep the setting tool square to avoid splitting the rivet.



**Caution:**  
The clinched end of the rivet must have a washer in place prior to clinching. Failure to use the washer or use of excessive force when clinching the rivet will fracture the friction lining.

- 4.4.6 The remaining rivets may be installed in any reasonable sequence following a crosswise pattern.



**Caution:**  
After replacement of friction material, a minimum wear-in period of four hours at 50% of the rated horsepower is recommended for the friction couple to achieve rated torque.

## 4.5 Friction Material Replacement (Sizes 18, 24, 36 and 48)

Note: When replacing friction material, it is recommended that the mating wear surface be replaced or machined flat to ensure good contact between the mating surfaces. See Table 14 for wear limits.

- 4.5.1 Refer to Section 6.0 for the appropriate friction disc (or block) replacement part numbers .



**Caution:**  
Use only genuine Airflex friction material. Use of material not of Airflex origin may result in un-predictable performance.

- 4.5.2 Disassemble the tensioner per Section 4.3.

- 4.5.3 Remove the old screws and and discard the old friction material.

Note: Use of a pinpoint torch to heat the screws and soften the Loctite<sup>®</sup> will ease removal of the screws.

- 4.5.4 Clean all burrs, corrosion etc. from the friction disc core or mounting surface.

- 4.5.5 Position the friction material to align the screw holes. Install several screws loosely at several of the outermost screw hole locations to properly align the friction discs or blocks.

For friction discs (sizes 18 and 24), install the remaining screws in an even, crosswise pattern per the procedure in the next paragraph. When installing screws in friction blocks (sizes 36 and 48), install and tighten the screws from the centermost position in the block, then progress towards the outer edges of the block.

Following the above pattern, install one screw at a time by applying Loctite<sup>®</sup> #262 to the screw threads (use Loctite<sup>®</sup> #242 for size 18) and tightening the screw to the proper torque value. Tighten screws to 15 ft.-lb. (75 in.-lb. for size 18). Install and torque each remaining screw immediately after application of Loctite<sup>®</sup>, then proceed to the next screw. Be sure to remove, apply Loctite<sup>®</sup> and properly tighten the initial screws used for alignment of the friction disc or block.

Note the relevant safety precautions in the following column when assembling screws.



**Warning:**

**Loctite<sup>®</sup> may cure prior to properly tightening the screw if not tightened to the proper torque value immediately after installation.**



**Caution:**

**Use only Airflex-supplied screws.**



**Caution:**

**Loctite<sup>®</sup> #262 must be shaken prior to application.**



**Caution:**

**Loctite<sup>®</sup> #262 may irritate sensitive skin. Refer to the product label for proper safety precautions.**

- 4.5.6 Tensioner friction disc assemblies (7) of size 36" and larger require that the friction material be machined flat after assembly, to allow for even contact and minimize wear-in. Machine the friction surface perpendicular to the bore splines within .003", and parallel to the opposite face within .010".



**Warning:**

**Use appropriate safety equipment and dust collection systems when machining friction material.**

- 4.5.7 After replacement of friction material, re-assemble the tensioner per Section 4.9. During start-up, observe wear-in and operation precautions per Section 3.0, Operation.



**Caution:**

**After replacement of friction material, a minimum wear-in period of four hours at 50% of the rated horsepower is recommended for the friction couple to achieve rated torque.**

## 4.6 Wear Plate Replacement

Note: When replacing wear surfaces, it is recommended that the mating friction material be replaced or machined flat to ensure good contact between the mating surfaces. See Table 14 for wear limits.

- 4.6.1 Disassemble the tensioner per Section 4.3.
- 4.6.2 Remove the screws and locknuts holding the wear plates and remove the wear plates. If the wear plates cannot be easily lifted off, gently tap the O.D. to break the gasket seal.



**Caution:**

**Do not attempt to break the gasket seal by prying between the wear plate and housing. Damage to the sealing surfaces may occur.**

- 4.6.3 Inspect the water passages and, if necessary, use a wire brush to clean them. If re-painting is necessary, sand blast the water passages and paint the surfaces with PLASITE<sup>®</sup> Epoxy #9052 Polymine coating. Dry film thickness should be 8 to 12 mils (0,2 to 0,3 mm). Be careful not to allow the paint to get into the seal grooves or onto the face of the support nubs.



**Caution:**

Follow manufacturer's instructions and proper safety precautions for application of epoxy coatings.



**Caution:**

If nubs in the water cavity are severely corroded, wear plates may not be properly supported. Replace the pressure plate, reaction plate or mounting flange, if necessary.

- 4.6.4 Clean and completely dry the sealing surfaces at the I.D. and O.D. on the pressure plate (14), reaction plate(s) (31) and mounting flange (2). These surfaces should be free of nicks and scratches to prevent leaks. Minor nicks and scratches may be filled with Loctite Superflex® #596 Sealant during assembly.
- 4.6.5 Apply a uniform bead of Loctite Superflex® #596 Sealant in the grooves of the pressure plate, reaction plate(s) and/or mounting flange. Recommended bead diameter is 0.060" - 0.090" (1,5 mm - 2,3 mm) for all sizes except for size 48WCB2. For size 48, refer to procedure 4.6.5.1 for proper sealant application procedure. For all other sizes, skip to section 4.6.6 after application of sealant.



**Caution:**

Loctite Superflex® #596 Silicon Sealant will begin to set up and skin over in approximately 10 minutes. The wear plate must be fastened to the mating component within 10 minutes of applying the sealant.

- 4.6.5.1 The 48WCB2 incorporates a dual groove for both the Superflex® #596 Sealant and an O-ring. An initial bead of sealant .030"-.060" (0,7 - 1,5mm) in size must be applied to the bottom of the deep groove in order to hold the O-ring in place. See Figure 14.
- 4.6.5.2 Install the O-rings (I.D. and O.D.) on top of the sealant, working them into position so that they lay flat in the bottom of the groove. See Figure 15. A second bead of sealant .060"-.090" (1,5mm - 2,3mm) in size should then be applied in the shallow groove. See Figure 16.

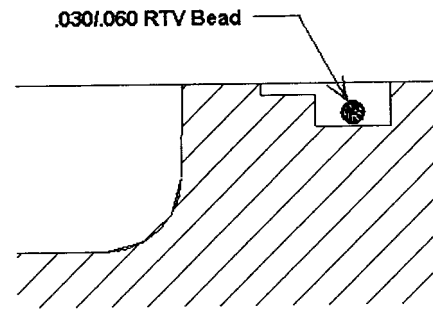

Figure 14

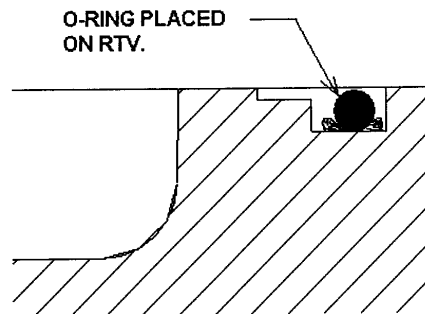

Figure 15

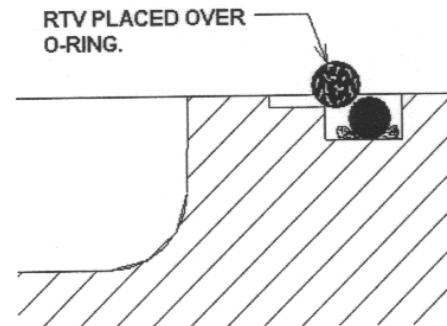

Figure 16

- 4.6.6 Inspect the new wear plates and remove any scratches or raised edges with very fine sandpaper or steel wool. Position the smoothest side of the wear plate on the mating surface being careful to align the holes.
- 4.6.7 Install new screws and locknuts provided with the wear plate replacement kit and secure finger tight. Sizes 18 and larger require clamp rings to be positioned between the screws or nuts and the wear plates. See Figure 2.

**! Caution:**

To prevent excessive warpage and to ensure a good seal, the following hardware tightening procedure must be followed.

- 4.6.8 For each wear plate being replaced, follow the tightening sequence shown in Figure 17 for the first 16 screws. The remaining screws may be tightened in any reasonable crosswise pattern. See Table 11 for tightening torque values.

Model	Size	Torque
8 WCB2	#10-24NC	5 (7)
14 WCB2	1/4-20NC2	12 (16)
18 WCB2	5/16-18NC	21 (28)
24 WCB2	5/16-18NC	21 (28)
36 WCB2	3/8-16NC2	40 (54)
48 WCB2	3/8-16NC2	40 (54)

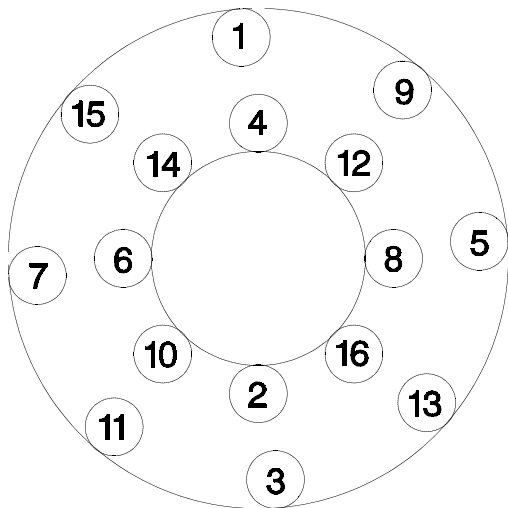

Figure 17

Model	Size
8 WCB2	3/8-18NPT
14 WCB2	1/2-14NPT
18 WCB2	1/2-14NPT
24 WCB2	3/4-14NPT
36 WCB2	1 1/4-11NPT
48 WCB2	1 1/4-11NPT

**! Caution:**

Allow the Loctite Superflex® #596 Sealant 24 hours to completely cure before performing the following leak test procedure.

- 4.6.9 24 hours after completion of assembly, each water cavity should be checked for leaks.
- 4.6.9.1 Using lifting straps, suspend each assembly with the water outlet port at the 12 o'clock position. Connect a water supply line to the inlet port (at 6 o'clock position). In reaction plates, plug the remaining inlet port. See Table 12 for water port sizes.
- 4.6.9.2 Slowly fill with water to purge all air from water cavities.
- 4.6.9.3 Install pipe plug(s) in the outlet port(s) and apply appropriate water pressure (40 psi (2.7 bar) for size 36 and 48 WCB2 units and 45 psi (3.1 bar) for all other sizes) measured at the inlet. Maintain this pressure for a minimum of 30 minutes.
- 4.6.9.4 Check for leakage at O.D. and I.D. seal areas. **NO** leakage is allowed.
- 4.6.9.5 If the assembly leaks, check the torque on each screw and re-test. If leaks still occur, the wear plate(s) or sealant groove may be damaged. Repeat procedure from 4.6.1.
- 4.6.9.6 Follow steps in Section 4.9 to reassemble the tensioner.
- 4.6.10 Machining of the wear surfaces is required for sizes 36" and 48" after replacement of the wear plates or the adjoining friction material. See Figure 18 for machining specifications. Clean all wear surfaces after machining to remove any residual contaminates.

125 / - 63 /

100% CLEAN-UP  
WITHIN THIS AREA TO  
DIMENSION SHOWN BELOW.  
.001" MAX ALLOWABLE CUTTING  
TOOL MISMATCH. SURFACE TO BE  
CLEAN AND FREE OF SHARP EDGES.

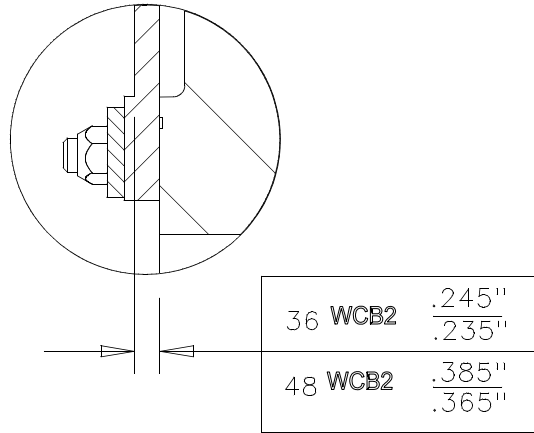
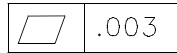
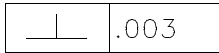

Figure 18

**Warning:**

**Failure to machine wear plates flat could result in poor contact between the friction couple and subsequent reduction or erratic torque of the tensioner.**

**Caution:**

**After replacement or machining of wear plates, a minimum wear-in period of four hours at 50% of the rated horsepower is recommended for the friction couple to achieve rated torque.**

## 4.7 Cylinder Seal Replacement

Note: Item numbers (#) are shown on Figures 1 and 2.

- 4.7.1 Disconnect the air connections.
- 4.7.2 While supporting the cylinder, loosen the locknuts (18) ONE TURN AT TIME and in an alternating (crosswise) pattern until the spring force is completely relieved. Remove the locknuts and washers (17). Deep well sockets are required for removal of the locknuts.
- 4.7.3 Using lifting equipment, carefully remove the cylinder (19) and piston (33) as an assembly. Set aside in a clean area.
- 4.7.4 Place the cylinder and piston assembly with the piston facing down on blocks approximately 6" (150 mm) high. The blocks must only contact the cylinder (19) so that the piston (33) will be free to move out of the cylinder bore.

- 4.7.5 If a regulated air line is available, the piston can be partially ejected from the cylinder by applying no more than 15 PSIG (1.0 bar) to the cylinder.

**Caution:**

**Application of a higher pressure may cause damage to the components.**

- 4.7.6 To complete the removal of the piston from the cylinder, open all air inlets. Alternately insert a 0.50" (12 mm) diameter by 6" (150 mm) long wood dowel into each air inlet and gently tap the piston with a mallet so that it moves evenly out of the cylinder. Be careful not to damage the sealing surfaces of the piston or cylinder by cocking the piston in the cylinder.
- 4.7.8 Noting how the lips of the seals are oriented in the piston grooves, remove the seals.
- 4.7.9 Inspect the cylinder sealing surface condition for nicks or scratches or any other defect which may prevent the seals from being effective. See Table 14 for wear limits of the sealing surface. Replace the cylinder, if necessary.
- 4.7.10 Thoroughly clean the seal grooves in the piston (#) and apply a thin, even coat of Dow Corning® 55 O-ring lubricant to the piston seal grooves and chamfer on the piston, the sealing surfaces in the cylinder (19), and the seals (21)(23).
- 4.7.11 Install the new seals in the grooves in the piston, noting the orientation of the seal lips. See Figure 19.
- 4.7.12 Position the cylinder on a flat level surface so that the pressure cavity faces upward.

- 4.7.13 Carefully place the piston onto the cylinder with the chamfered edge of the piston facing downward, taking special care to avoid damaging the seal lips.
- 4.7.14 Gradually apply an evenly distributed force to press the piston into the cylinder being sure not to cock the piston which may damage the sealing surfaces. The use of 'C-clamps' may assist with the assembly process.
- 4.7.15 Using a lifting strap, slide the cylinder/piston assembly onto the studs.
- 4.7.16 Lubricate the threads on the end of the studs with 30 wt. oil or anti-seizing compound and install the washers (17) and locknuts (18) .
- 4.7.17 While supporting the weight of the cylinder/piston assembly, tighten the locknuts, ONE TURN AT A TIME and in an alternating (crosswise) pattern until the cylinder is seated firmly against the clamp tubes. Torque the locknuts to the appropriate value. See Table 4.



**Caution:**  
**The locknuts (18) must be tightened gradually to prevent damage to the tensioner components.**

- 4.7.18 Connect an air supply line to one of the ports in the cylinder, plugging the remaining port(s).
- 4.7.19 Perform an air test by applying 80 PSIG (5.5 bar) to engage the tensioner. Shut off the air supply. If the air pressure does not drop below 70 PSIG (4.8 bar) after 10 minutes, the seals have been properly installed. If excessive leaking is found, disassemble the piston / cylinder and inspect the seals or sealing surfaces for damage. repair or replace components as required.

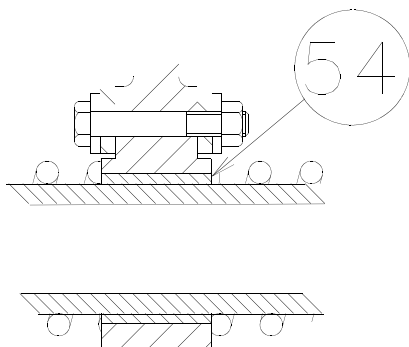
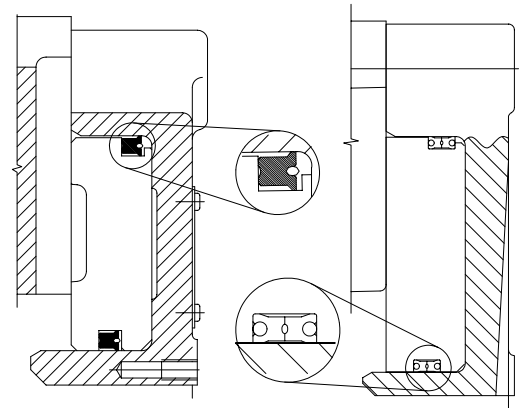

Figure 20



8 & 14  
WCB2

18, 24, 36 &  
48 WCB2

Figure 19

## 4.8 Bushing Replacement

Note: Some pressure plate and reaction plates have bushings installed in the reaction holes. (Typically corrosion resistant units, and older size 36" tensioners). See Figure 20. If applicable, replacement of the bushings can be performed per the following procedures.

- 4.8.1 Disassemble per Section 4.3.
- 4.8.2 Refer to the wear limits in Table 14 to determine if the bushings (54) require replacement.
- 4.8.3 Heat up the area around each bushing to soften the Loctite® and press out the old bushings.
- 4.8.4 Clean the bores in the mating component, removing any residual Loctite® .
- 4.8.5 Apply Loctite® #RC601, 635 or 680 to the bushing O.D. and mating hole in the reaction plate using a swab. Apply enough liquid to entirely fill the space between the parts. Install the bushings by twisting the bushing while pushing it down, until it is flush with the casting surface. Inspect to see that a ring of liquid adhesive is visible at the parting line. Reapply Loctite if required. Allow the Loctite to cure for 15 minutes before moving the sub assembly.
- 4.8.6 Assemble the tensioner per section 4.9, as required.

## 4.9 Assembly Procedures

Note: Friction discs and water jackets (mounting flange, end plate, and reaction plate- if applicable) should be assembled per the appropriate maintenance procedures prior to final assembly of the tensioner.

4.9.1 Position the mounting flange (1) on a flat, level surface, mounting face down.

4.9.2 Install the studs (6) into the mounting flange. The stud end with the shorter length of threads is to be assembled into the mounting flange. Clean the stud end to be assembled by applying Loctite Locquic<sup>®</sup> Primer Grade "T" to the threads. After the threads have dried, apply Loctite<sup>®</sup> #271 on the threads to be assembled and insert the stud completely into the threaded hole in the mounting flange so that the installed end is flush or slightly recessed inside the face of mounting flange. See Figure 1. Using a machinists square as a reference, hold the stud in position so that it remains perpendicular to the machined surface of the mounting flange until the Loctite<sup>®</sup> has cured. Repeat for the remaining studs.



### **Caution:**

**Loctite Locquic<sup>®</sup> Primer Grade "T" contains harmful vapors. Refer to the product label and follow proper safety precautions.**



### **Caution:**

**The end of the stud must not extend past the mounting surface of the mounting flange.**

4.9.3 Install the appropriate number of wear spacers (29) and clamp tubes (12) over the studs.

4.9.4 Place a friction disc assembly onto the mounting flange. Center the friction disc.

4.9.5 For sizes 8, 14 and 18, place a release spring (34) over every other clamp tube. For sizes 24, 36 and 48, install a release spring over every clamp tube. For single disc WCB2 tensioners, proceed to Section 4.9.9.

4.9.6 Noting the location of the water inlets in the mounting flange, lift the reaction plate (30) into position, align the water inlets with those in the mounting flange, and slide the reaction plate over the studs and clamp tubes.

4.9.7 For sizes 8, 14 and 18, place a release spring (34) over every other clamp tube. For sizes 24, 36 and 48, install a release spring over every clamp tube.

4.9.8 Place friction disc assembly onto the reaction plate. Repeat the sequence of steps 4.9.5 through 4.9.8 until all friction discs, reaction plates and release springs are assembled.

4.9.9 Noting the location of the water inlets in the mounting flange, lift the pressure plate (13) into position and align the water inlets with those in the mounting flange. Slide the pressure plate over the studs and clamp tubes.

4.9.10 Thoroughly clean the seal grooves in the piston (33) and apply a thin, even coat of Dow Corning<sup>®</sup> 55 O-ring lubricant to the piston seal grooves and chamfer on the piston, the sealing surfaces in the cylinder (19), and the seals (21) (23).

4.9.11 Install the new seals in the grooves in the piston, noting the orientation of the seal lips. See Figure 17.

4.9.12 Position the cylinder on a flat level surface so that the pressure cavity faces upward.

4.9.13 Carefully place the piston onto the cylinder with the chamfered edge of the piston facing downward, taking special care to avoid damaging the seal lips.

4.9.14 Gradually apply an evenly distributed force to press the piston into the cylinder being sure not to cock the piston which may damage the sealing surfaces or seals. The use of 'C-clamps' may assist with the assembly process.

4.9.15 Lift the cylinder/piston assembly into position and slide it over the studs, noting the orientation of the ports on the cylinder face.

4.9.16 Lubricate the threads on the end of the studs with 30 wt. oil or anti-seizing compound and assemble the washers (17) and locknuts (18).

4.9.17 Tighten the locknuts, ONE TURN AT A TIME and in an alternating ( crosswise) pattern until the cylinder is seated firmly against the clamp tubes. Torque the locknuts to the appropriate value. See Table 4.



### **Caution:**

**The locknuts (18) must be tightened gradually to prevent damage to the tensioner components.**

4.9.18 Re-install the tensioner per Section 2.0.

## 4.10 Corrosion Protection



### **Caution:**

**All previously painted areas must be touched up after maintenance or installation to provide corrosion protection.**

- 4.10.1 Clean any contamination, scale, or loose paint from disturbed surfaces.
- 4.10.2 Touch up any disturbed area with an organic zinc primer.
- 4.10.3 Paint areas with two coats of a high solid two part, marine grade epoxy paint as per manufacturers instructions.

## 5.0 ORDERING INFORMATION/ TECHNICAL ASSISTANCE

### 5.1 Equipment Reference

- 5.1.1 In any correspondence regarding Airflex equipment, refer to the information on the product nameplate and call or write:

Eaton Corporation  
Airflex Division  
9919 Clinton Rd.  
Cleveland, Ohio 44144

Tel: (216) 281-2211  
Fax: (216) 281-3890  
Internet: **www.airflex.com**

Loctite, Locquic, and Superflex are registered trademarks of Loctite Corporation.

Polypak is a registered trademark of Parker Hannifin Corporation

MOLUB-ALLOY is a trademark of Castrol Industrial Lubricants.

**TABLE 13**  
**Wear Limits for WCB2 Components (Ref. Figs. 1 & 2 and Section 4.0)**

Item	Description	Wear Limit	Remarks
#3 Wear Plate	Friction Wear Surface	Maximum wear is: 8, 14, 18 WCB2 - 0.030" 24 WCB2 - 0.045" 36 WCB2 - 0.050" 48 WCB2 - 0.060"	Wear will be in form of even wear or circular grooves in the copper surface.
#8 Friction Disc	Friction Material	Fully worn at bottom of dust groove, or step on O.D. for size 48". See Figure 6. Friction material must also be replaced if contaminated with oil or grease.	Brakes have adjustment provision. See Section 4.2.
#9, #28 Friction Disc Core & Gear	Gear Backlash	Maximum total backlash is 0.060" (1.5 mm).	If step is worn in gear, gear must be replaced.
#12 Clamp Tube	Reaction Area	Maximum wear is 0.015" (0.38 mm).	Wear will be in the form of a notch or step on the side of the tube.
#13, #30, #54	Reaction Holes	Maximum wear is 0.031" (0.80 mm).	Wear will be in the form of elongation of the holes. Original hole diameters are shown on the table below.
#19 Cylinder	Seal Area	Maximum radial wear is 0.005" (0.13 mm).	Wear will be in the form of grooves where the seals contact the cylinder wall.
#34 Spring	Spring Free Height	Minimum free height shown on the table below.	Original free height shown on the table below. Springs must be replaced in complete sets.

**Reaction hole size (NEW) and Spring Free Height limit**

Size	Original Reaction Hole Sizes (#14, #31 & 54) inches(mm)	Spring (#34) Free Height	
		Original inches(mm)	Minimum inches(mm)
<b>8WCB2</b>	0.938" (23,83)	2.14"(54,36)	2.07" (52,58)
<b>14WCB2</b>	1.312" (33,33)	3.16" (80,26)	3.06 (77,72)
<b>18WCB2</b>	1.312" (33,33)	3.16" (80,26)	3.06" (77,72)
<b>24WCB2</b>	1.668" (42,88)	4.000" (101,6)	3.88" (98,55)
<b>36WCB2</b>	2.065" (52,45)	4.000" (101,6)	3.88" (98,55)
<b>48WCB2</b>	2.375" (60,33)	5.000" (127,0)	4.85" (123,19)

<b>6.1 Parts (Standard)</b>		<b>118 WCB2 146461A (514821)</b>		<b>218 WCB2 146462A (514822)</b>		<b>318 WCB2 146463A (513823)</b>		<b>418 WCB2 146464A (513824)</b>	
<b>Item</b>	<b>Description</b>	<b>Part Number</b>	<b>Qty</b>	<b>Part Number</b>	<b>Qty</b>	<b>Part Number</b>	<b>Qty</b>	<b>Part Number</b>	<b>Qty</b>
1	*Mounting Flange Sub Assy. (Includes Items 2,3,50 & 51)	513232-01	1	513232-01	1	513232-01	1	513232-01	1
2	Mounting Flange	513207	1	513207	1	513207	1	513207	1
3	Wear Plate	412953	2	412953	4	412953	6	412953	8
6	Stud	000245X0057	12	000245X0063	12	000245X0085	12	000245X0057	12
8	Friction Block	513657	2	513657	4	513657	6	513657	8
9	Friction Disc Core	513666	1	513666	2	513666	3	513666	4
12	Clamp Tube	306956-11	12	306956--12	12	306956-34	12	306956-22	12
13	*Pressure Platesub Assy. (Includes Items 3,14, 50 & 51)	513232-03	1	513232-03	1	513232-03	1	513232-03	1
14	Pressure Plate	513214	1	513214	1	513214	1	513214	1
17	Flat Washer	000153X0727	12	000153X0727	12	000153X0727	12	000153X0727	12
18	Locknut	000110X0030	12	000110X0030	12	000110X0030	12	000110X0030	12
19	Cylinder	512693	1	512693	1	512693	1	512693	1
21	Polypak Seal	000402X0021	2	000402X0021	2	000402X0021	2	000402X0021	2
23	Polypak Seal	000402X0022	2	000402X0022	2	000402X0022	2	000402X0022	2
28	Gear (not included with assembly)	302813-####	1	302907-####	1	413208-####	1	414111-####	1
29	Wear Spacer	N/A	N/A	308388-02	12	308388-02	24	308388-02	36
30	*Reaction Plate Sub Assy. (Includes Items 3, 31, 50 & 51)	N/A	N/A	513232-02	1	513232-02	2	513232-02	3
31	Reaction Plate	N/A	N/A	513217	1	513217	2	513217	3
33	Piston	512761	1	512761	1	512761	1	512761	1
34	Release Spring	307629	6	307629	12	307629	18	307629	24
50	Inner Support Ring	413105	8	413105	16	413105	24	413105	32
51	Outer Support Ring	413106	8	413106	16	413106	24	413106	32
57	Flat Head Screw	000153X1147	48	000153X1147	96	000153X1147	144	000153X1147	192

\* - Individual parts breakdown for standard WCB2 subassemblies are in section 6.1.2

<b>6.1 Parts (Standard)</b>		<b>124 WCB2 146465A (514825)</b>		<b>224 WCB2 146466A (514826)</b>		<b>324 WCB2 146467A (514827)</b>		<b>424 WCB2 146468A (514828)</b>	
<b>Item</b>	<b>Description</b>	<b>Part Number</b>	<b>Qty</b>	<b>Part Number</b>	<b>Qty</b>	<b>Part Number</b>	<b>Qty</b>	<b>Part Number</b>	<b>Qty</b>
1	*Mounting Flange Sub Assy. (Includes Items 2,3,50 & 51)	513348-01	1	513348-01	1	513348-01	1	513348-01	1
2	Mounting Flange	513337	1	513337	1	513337	1	513337	1
3	Wear Plate	508459	2	508459	4	508459	6	508459	8
6	Stud	000245X0069	12	000245X0071	12	000245X0081	12	000245X0082	12
8	Friction Disc	508725	2	508725	4	508725	6	508725	8
9	Friction Disc Core	510745	1	510745	2	510745	3	510745	4
12	Clamp Tube	306542-05	12	306542-20	12	306542-23	12	306542-24	12
13	*Pressure Platesub Assy. (Includes Items 3,14, 50 & 51)	513348-03	1	513348-03	1	513348-03	1	513348-03	1
14	Pressure Plate	513345	1	513345	1	513345	1	513345	1
17	Flat Washer	000153X0641	12	000153X0641	12	000153X0641	12	000153X0641	12
18	Locknut	000110X0073	12	000110X0073	12	000110X0073	12	000110X0073	12
19	Cylinder	513264	1	513264	1	513264	1	513264	1
21	Polypak Seal	000402X0023	2	000402X0023	2	000402X0023	2	000402X0023	2
23	Polypak Seal	000402X0024	2	000402X0024	2	000402X0024	2	000402X0024	2
28	Gear (not included with assembly)	411672	1	410970	1	412433	1	413195	1
29	Wear Spacer	N/A	N/A	308396	12	308396	24	308396	36
30	*Reaction Plate Sub Assy. (Includes Items 3, 31, 50 & 51)	N/A	N/A	513348-02	1	513348-02	2	513348-02	3
31	Reaction Plate	N/A	N/A	513343	1	513343	2	513343	3
33	Piston	513317	1	513317	1	513317	1	513317	1
34	Release Spring	416751-02	12	416751-02	24	416751-02	36	416751-02	48
50	Inner Support Ring	413107	6	413107	12	413107	18	413107	24
51	Outer Support Ring	413108	10	413108	20	413108	30	413108	40
57	Flat Head Screw	000294X407	36	000294X407	72	000294X407	108	000294X407	144
105	Pipe Plug	000077x0021	1	000077x0021	1	000077x0021	1	000077x0021	1

\* - Individual parts breakdown for standard WCB2 subassemblies are in section 6.1.2

<b>6.1 Parts (Standard)</b>		<b>136 WCB2 146469A (514829)</b>		<b>236 WCB2 146470A (514830)</b>		<b>336 WCB2 146471A (513831)</b>		<b>436 WCB2 146472A (513832)</b>	
<b>Item</b>	<b>Description</b>	<b>Part Number</b>	<b>Qty</b>	<b>Part Number</b>	<b>Qty</b>	<b>Part Number</b>	<b>Qty</b>	<b>Part Number</b>	<b>Qty</b>
<b>1</b>	*Mounting Flange Sub Assy. (Includes Items 2,3,50 & 51)	513985-01	1	513985-01	1	513985-01	1	513985-01	1
<b>2</b>	Mounting Flange	513986	1	513986	1	513986	1	513986	1
<b>3</b>	Wear Plate	416527	2	416527	4	416527	6	416527	8
<b>6</b>	Stud	307111-04	16	307111-10	16	307111-05	16	307111-07	16
<b>7</b>	*Friction Disc sub Assy. (Item 8 & 9)	513990	1	513990	2	513990	3	513990	4
<b>8</b>	Friction Block	513658	16	513658	32	513658	48	513658	64
<b>9</b>	Friction Disc Core	513667	1	513667	2	513667	3	513667	4
<b>12</b>	Clamp Tube	308204-07	16	308204-02	16	308204-04	16	308204-05	16
<b>13</b>	*Pressure Platesub Assy. (Includes Items 3,14, 50 & 51)	513985-03	1	513985-03	1	513985-03	1	513985-03	1
<b>14</b>	Pressure Plate	512860	1	512860	1	512860	1	512860	1
<b>17</b>	Flat Washer	000067X0042	16	000067X0042	16	000067X0042	16	000067X0042	16
<b>18</b>	Locknut	000110X0075	16	000110X0075	16	000110X0075	16	000110X0075	16
<b>19</b>	Cylinder	513988	1	513988	1	513988	1	513988	1
<b>21</b>	Polypak Seal	000402X0005	2	000402X0005	2	000402X0005	2	000402X0005	2
<b>23</b>	Polypak Seal	000402X0006	2	000402X0006	2	000402X0006	2	000402X0006	2
<b>28</b>	Gear (not included with assembly)	416538	1	416536	1	416535	1	416537	1
<b>29</b>	Wear Spacer	N/A	N/A	308397	16	308397	32	308397	48
<b>30</b>	*Reaction Plate Sub Assy. (Includes Items 3, 31, 50 & 51)	N/A	N/A	513985-02	1	513985-02	2	513985-02	3
<b>31</b>	Reaction Plate	N/A	N/A	513989	1	513989	2	513989	3
<b>33</b>	Piston	512858	1	512858	1	512858	1	512858	1
<b>34</b>	Release Spring	416751-01	16	416751-01	32	416751-01	48	416751-01	64
<b>50</b>	Inner Support Ring	414032-01	12	414032-01	24	414032-01	36	414032-01	48
<b>51</b>	Outer Support Ring	414033-01	18	414033-01	36	414033-01	54	414033-01	72
<b>57</b>	Flat Head Screw	000294X0407	144	000294X0407	288	000294X0407	432	000294X0407	576
<b>105</b>	Pipe Plug	000077X0021	1	000077X0021	1	000077X0021	1	000077X0021	1

\* - Individual parts breakdown for standard WCB2 subassemblies are in section 6.1.2

<b>6.1 Parts (Standard)</b>		<b>148 WCB2 146473A (600433)</b>		<b>248 WCB2 146474A (600434)</b>		<b>348 WCB2 146475A (600435)</b>		<b>448 WCB2 146476A (600436)</b>	
<b>Item</b>	<b>Description</b>	<b>Part Number</b>	<b>Qty</b>	<b>Part Number</b>	<b>Qty</b>	<b>Part Number</b>	<b>Qty</b>	<b>Part Number</b>	<b>Qty</b>
<b>1</b>	*Mounting Flange Sub Assy. (Includes Items 2,3,50 & 51)	514329-05	1	514329-05	1	514329-05	1	514329-05	1
<b>2</b>	Mounting Flange	514749	1	514749	1	514749	1	514749	1
<b>3</b>	Wear Plate	416690	2	416690	4	416690	6	416690	8
<b>6</b>	Stud	307111-23	16	307111-22	16	307111-21	16	307111-20	16
<b>7</b>	*Friction Disc sub Assy. (Item 8 & 9)	514325	1	514325	2	514325	3	514325	4
<b>8</b>	Friction Block	514286	16	514286	32	514286	48	514286	64
<b>9</b>	Friction Disc Core	514287	1	514287	2	514287	3	514287	4
<b>12</b>	Clamp Tube	308440-08	16	308440-07	16	308440-06	16	308440-05	16
<b>13</b>	*Pressure Platesub Assy.(Includes Items 3,14, 50 & 51)	514329-01	1	514329-01	1	514329-01	1	514329-01	1
<b>14</b>	Pressure Plate	514513	1	514513	1	514513	1	514513	1
<b>17</b>	Flat Washer	000067X0042	16	000067X0042	16	000067X0042	16	000067X0042	16
<b>18</b>	Locknut	000110X0075	16	000110X0075	16	000110X0075	16	000110X0075	16
<b>19</b>	Cylinder	514516	1	514516	1	514516	1	514516	1
<b>21</b>	Polypak Seal	000402X0042	2	000402X0042	2	000402X0042	2	000402X0042	2
<b>23</b>	Polypak Seal	000402X0044	2	000402X0044	2	000402X0044	2	000402X0044	2
<b>28</b>	Gear (not included in assembly)	416794	1	416795	1	416688	1	416797	1
<b>29</b>	Wear Spacer	N/A	N/A	308398	16	308398	32	308398	48
<b>30</b>	*Reaction Plate Sub Assy. Includes Items 3, 31, 50 & 51)	N/A	N/A	514329-02	1	514329-02	2	514329-02	3
<b>31</b>	Reaction Plate	N/A	N/A	514514	1	514514	2	514514	3
<b>33</b>	Piston	514745	1	514745	1	514745	1	514745	1
<b>34</b>	Release Spring	416751-04	16	416751-04	32	416751-04	48	416751-04	64
<b>50</b>	Inner Support Ring	416618	10	416618	20	416618	30	416618	40
<b>51</b>	Outer Support Ring	416673	20	416673	40	416673	60	416673	80
<b>57</b>	Flat Head Screw	000294X0407	224	000294X0407	448	000294X0407	672	000294X0407	896
<b>105</b>	Pipe Plug	000077X0021	1	000077X0021	1	000077X0021	1	000077X0021	1

\* - Individual parts breakdown for standard WCB2 subassemblies are in section 6.1.2

## 6.1.2 Sub-assemblies (Standard)

6.1.2.1 Parts Breakdown of WCB2 Mounting Flange Sub-assemblies (Item Numbers (#) shown in Figure 1,2 & 21)						
Model ⇒	8 WCB2 Mounting Flange S/A	14 WCB2 Mounting Flange S/A	18 WCB2 Mounting Flange S/A	24 WCB2 Mounting Flange S/A	36 WCB2 Mounting Flange S/A	48 WCB2 Mounting Flange S/A
Part Description↓	Part No. (Qty)	Part No. (Qty)	Part No. (Qty)	Part No. (Qty)	Part No. (Qty)	Part No. (Qty)
<b>Sub Assembly Part #</b>	512508-01 (1)	513300-01 (1)	513232-01 (1)	513348-01 (1)	513985-01 (1)	514329-05 (1)
<b>Mounting Flange(2)</b>	512496 (1)	512375 (1)	513207 (1)	513337 (1)	513986 (1)	514749 (1)
<b>Screw (4)</b>	000030x5407(42)	000153x1017 (60)	000153x0726 (80)	000153x0685 (90)	000153x0842 (108)	N/A
<b>Nut (5)</b>	000153x1049 (42)	000153x1061 (60)	000153x0642 (80)	000153x0642 (90)	000153X0844 (108)	000153x0844 (120)
<b>Wear Plate (3)</b>	512507 (1)	415212 (1)	412953 (1)	508459 (1)	416527 (1)	416690 (1)
<b>Inner Support Ring (50)</b>	N/A	N/A	413105 (4)	413107 (3)	414032-01 (6)	416618 (5)
<b>outer support Ring (51)</b>	N/A	N/A	413106 (4)	413108 (5)	414033-01 (9)	416673 (10)
<b>Hex Head Screw (4a)</b>	N/A	N/A	N/A	N/A	N/A	000153X0843 (120)
<b>Inner O-ring (I)</b>	N/A	N/A	N/A	N/A	N/A	000073x0410 (1)
<b>Outer O-ring (O)</b>	N/A	N/A	N/A	N/A	N/A	000073x0411 (1)

6.1.2.2 Parts Breakdown of WCB2 Pressure Plate Sub-assemblies (Item Numbers (#) shown in Figure 1,2 & 21)						
Model ⇒	8 WCB2 Pressure Plate S/A	14 WCB2 Pressure Plate S/A	18 WCB2 Pressure Plate S/A	24 WCB2 Pressure Plate S/A	36 WCB2 Pressure Plate S/A	48 WCB2 Pressure Plate S/A
Part Description↓	Part No. (Qty)	Part No. (Qty)	Part No. (Qty)	Part No. (Qty)	Part No. (Qty)	Part No. (Qty)
<b>Sub Assembly Part #</b>	512508-03 (1)	513300-03 (1)	513232-03 (1)	513348-03 (1)	513985-03 (1)	514329-01 (1)
<b>Pressure Plate(14)</b>	512502 (1)	512377 (1)	513214 (1)	513345 (1)	512260 (1)	514513 (1)
<b>Screw (4)</b>	000030x5407(42)	000153x1017 (60)	000153x0726 (80)	000153x0685 (90)	000153x0842 (108)	N/A
<b>Nut (5)</b>	000153x1049 (42)	000153x1061 (60)	000153x0642 (80)	000153x0642 (90)	000153X0844 (108)	000153x0844 (120)
<b>Wear Plate (3)</b>	512507 (1)	415212 (1)	412953 (1)	508459 (1)	416527 (1)	416690 (1)
<b>Inner Support Ring (50)</b>	N/A	N/A	413105 (4)	413107 (3)	414032-01 (6)	416618 (5)
<b>outer support Ring (51)</b>	N/A	N/A	413106 (4)	413108 (5)	414033-01 (9)	416673 (10)
<b>Hex Head Screw (4a)</b>	N/A	N/A	N/A	N/A	N/A	000153X0843 (120)
<b>Inner O-ring (I)</b>	N/A	N/A	N/A	N/A	N/A	000073x0410 (1)
<b>Outer O-ring (O)</b>	N/A	N/A	N/A	N/A	N/A	000073x0411 (1)

6.1.2.3 Parts Breakdown of WCB2 Reaction Plate Sub-assemblies (Item Numbers (#) shown in Figure 1,2 & 21)						
Model ⇒	8 WCB2 Reaction Plate S/A	14 WCB2 Reaction Plate S/A	18 WCB2 Reaction Plate S/A	24 WCB2 Reaction Plate S/A	36 WCB2 Reaction Plate S/A	48 WCB2 Reaction Plate S/A
Part Description↓	Part No. (Qty)	Part No. (Qty)	Part No. (Qty)	Part No. (Qty)	Part No. (Qty)	Part No. (Qty)
<b>Sub Assembly Part #</b>	512508-02 (1)	513300-02 (1)	513232-02 (1)	513348-02 (1)	513985-02 (1)	514329-02 (1)
<b>Reaction Plate (31)</b>	512507 (1)	512380 (1)	513217 (1)	513343 (1)	513989 (1)	514514 (1)
<b>Screw (4)</b>	000030x5407(42)	000153x1017 (60)	000153x0726 (80)	000153x0685 (90)	000153x0842 (108)	N/A
<b>Nut (5)</b>	000153x1049 (42)	000153x1061 (60)	000153x0642 (80)	000153x0642 (90)	000153X0844 (108)	000153x0844 (120)
<b>Wear Plate (3)</b>	512507 (1)	415212 (1)	412953 (1)	508459 (1)	416527 (1)	416690 (1)
<b>Inner Support Ring (50)</b>	N/A	N/A	413105 (4)	413107 (3)	414032-01 (6)	416618 (5)
<b>outer support Ring (51)</b>	N/A	N/A	413106 (4)	413108 (5)	414033-01 (9)	416673 (10)
<b>Hex Head Screw (4a)</b>	N/A	N/A	N/A	N/A	N/A	000153X0843 (120)
<b>Inner O-ring (I)</b>	N/A	N/A	N/A	N/A	N/A	000073x0410 (1)
<b>Outer O-ring (O)</b>	N/A	N/A	N/A	N/A	N/A	000073x0411 (1)

6.1.2.4 Parts Breakdown of WCB2 Friction disc Sub-assemblies (Item Numbers (#) shown in Figure 1 & 2)						
Model ⇒	8 WCB2 Friction Disc S/A	14 WCB2 Friction Disc S/A	18 WCB2 Friction Disc S/A	24 WCB2 Friction Disc S/A	36 WCB2 Friction Disc S/A	48 WCB2 Friction Disc S/A
Part Description↓	Part No. (Qty)	Part No. (Qty)	Part No. (Qty)	Part No. (Qty)	Part No. (Qty)	Part No. (Qty)
<b>Sub Assembly Part #</b>	512512 (1)	415208 (1)	N/A	N/A	513990 (1)	514325 (1)
<b>Friction Disc (8)</b>	512509 (2)	415227 (2)	N/A	N/A	513658 (16)	514286 (16)
<b>Friction Disc Core(9)</b>	512510 (1)	415207 (1)	N/A	N/A	513667 (1)	514287 (1)
<b>Screw (57)</b>	N/A	N/A	N/A	N/A	000294x0407 (144)	000294x0407 (224)
<b>Rivet (10)</b>	000130x0086 (20)	000130x0085 (30)	N/A	N/A	N/A	N/A
<b>Washer (11)</b>	000153x1065 (20)	000153x1064 (30)	N/A	N/A	N/A	N/A

<b>6.1 Parts (Standard)</b>		<b>114 WCB2 146458A (514818)</b>		<b>214 WCB2 146459A (514819)</b>		<b>314 WCB2 146460A (513820)</b>	
<b>Item</b>	<b>Description</b>	<b>Part Number</b>	<b>Qty</b>	<b>Part Number</b>	<b>Qty</b>	<b>Part Number</b>	<b>Qty</b>
1	*Mounting Flange Sub Assy. (Item 2 & 3)	513300-01	1	513300-01	1	513300-01	1
2	Mounting Flange	512375	1	512375	1	512375	1
3	Wear Plate	415212	2	415212	4	415212	6
6	Stud	000245x0058	6	000245X0054	6	000245X0083	6
7	*Friction Disc sub Assy. (Item 8 & 9)	415208	1	415208	2	415208	3
8	Friction Disc	415227	2	415227	4	415227	6
9	Friction Disc Core	415207	1	415207	2	415207	3
12	Clamp Tube	306956-07	6	306956-26	6	306956-27	6
13	*Pressure Platesub Assy. (Item 3 & 14)	513300-03	1	513300-03	1	513300-03	1
14	Pressure Plate	512377	1	512377	1	512377	1
17	Flat Washer	000067X0040	6	000067X0040	6	000067X0040	6
18	Locknut	000110X0030	6	000110X0030	6	000110X0030	6
19	Cylinder	512296	1	512296	1	512296	1
21	Polypak Seal	000402X0003	1	000402X0003	1	000402X0003	1
23	Polypak Seal	000402X0004	1	000402X0004	1	000402X0004	1
28	Gear (not included with assembly)	415454-####	1	415302-####	1	416303-####	1
29	Wear Spacer	N/A	N/A	308388-01	6	308388-01	12
30	*Reaction Plate Sub Assy. (Item 3 & 31)	N/A	N/A	513300-02	1	513300-02	2
31	Reaction Plate	N/A	N/A	512380	1	512380	2
33	Piston	512302	1	512302	1	512302	1
34	Release Spring	307629	3	307629	6	307629	9

\* - Individual parts breakdown for standard WCB2 subassemblies are in section 6.1.2

<b>6.2 Parts (Corrosion Resistant)</b>		<b>108 WCB2 146455AJ (514812)</b>		<b>208 WCB2 146456AJ (514813)</b>		<b>308 WCB2 146457AJ (513814)</b>	
<b>Item</b>	<b>Description</b>	<b>Part Number</b>	<b>Qty</b>	<b>Part Number</b>	<b>Qty</b>	<b>Part Number</b>	<b>Qty</b>
1	*Mounting Flange Sub Assy. (Item 2 & 3)						
2	Mounting Flange						
3	Wear Plate						
6	Stud						
7	*Friction Disc sub Assy. (Item 8 & 9)						
8	Friction Block						
9	Friction Disc Core						
12	Clamp Tube						
13	*Pressure Platesub Assy.(Item 3 & 14)						
14	Pressure Plate						
17	Flat Washer						
18	Locknut						
19	Cylinder						
21	Polypak Seal						
23	Polypak Seal						
28	Gear (not included in assembly)						
29	Wear Spacer						
30	*Reaction Plate Sub Assy. Includes Items 3, 31, 50 & 51)						
31	Reaction Plate						
33	Piston						
34	Release Spring						
50	Inner Support Ring						
51	Outer Support Ring						
57	Flat Head Screw						
105	Pipe Plug						

**CONTACT AIRFLEX FOR DETAILS**

\* - Individual parts breakdown for standard WCB2 subassemblies are in section 6.2.2

## 6.0 PARTS

6.1 Parts (Standard)		108 WCB2 146455A (514812)		208 WCB2 146456A (514813)		308 WCB2 146457A (514814)	
Item	Description	Part Number	Qty	Part Number	Qty	Part Number	Qty
1	*Mounting Flange Sub Assy. (Item2&3)	512508-01	1	512508-01	1	512508-01	1
2	Mounting Flange	512496	1	512496	1	512496	1
3	Wear Plate	512507	2	512507	4	512507	6
6	Stud	000245X0055	6	000245X0056	6	000245X0099	6
7	*Friction Disc sub Assy. (Item 8 & 9)	512512	1	512512	2	512512	3
8	Friction Disc	512509	2	512509	4	512509	6
9	Friction Disc Core	512510	1	512510	2	512510	3
12	Clamp Tube	307694-01	6	307694-02	6	307694-05	6
13	*Pressure Platesub Assy.(Item 3 & 14)	512508-03	1	512508-03	1	512508-03	1
14	Pressure Plate	512502	1	512502	1	512502	1
17	Flat Washer	000067X0041	6	000067X0041	6	000067X0041	6
18	Locknut	000110X0024	6	000110X0024	6	000110X0024	6
19	Cylinder	512483	1	512483	1	512483	1
21	Polypak Seal	000402X0001	1	000402X0001	1	000402X0001	1
23	Polypak Seal	000402X0002	1	000402X0002	1	000402X0002	1
28	Gear (not included with assembly)	415313-####	1	415314-####	1	416457-####	1
29	Wear Spacer	N/A	N/A	308393	6	308393	12
30	*Reaction Plate Sub Assy. (Item 3 & 31)	N/A	N/A	512508-02	1	512508-02	2
31	Reaction Plate	N/A	N/A	512504	1	512504	2
33	Piston	512500	1	512500	1	512500	1
34	Release Spring	307696	3	307696	6	307696	9

\* - Individual parts breakdown for standard WCB2 subassemblies are in section 6.1.2

<b>6.2 Parts (Corrosion Resistant)</b>		<b>114 WCB2 146458AJ (514818)</b>		<b>214 WCB2 146459 (514819)</b>		<b>314 WCB2 146460 (514820)</b>	
<b>Item</b>	<b>Description</b>	<b>Part Number</b>	<b>Qty</b>	<b>Part Number</b>	<b>Qty</b>	<b>Part Number</b>	<b>Qty</b>
1	*Mounting Flange Sub Assy. (Item 2 &3)						
2	Mounting Flange						
3	Wear Plate						
6	Stud						
7	*Friction Disc sub Assy. (Item 8 & 9)						
8	Friction Block						
9	Friction Disc Core						
12	Clamp Tube						
13	*Pressure Platesub Assy.(Item 3 & 14)						
14	Pressure Plate						
17	Flat Washer						
18	Locknut						
19	Cylinder						
21	Polypak Seal						
23	Polypak Seal						
28	Gear (not included in assembly)						
29	Wear Spacer						
30	*Reaction Plate Sub Assy. Includes Items 3, 31, 50 & 51)						
31	Reaction Plate						
33	Piston						
34	Release Spring						
50	Inner Support Ring						
51	Outer Support Ring						
57	Flat Head Screw						
105	Pipe Plug						

**CONTACT AIRFLEX FOR DETAILS**

\* - Individual parts breakdown for standard WCB2 subassemblies are in section 6.2.2

6.2 Parts (Corrosion Resistant)		118 WCB2 146461 (514821)		218 WCB2 146462AJ (514822)		318 WCB2 146463AJ (514823)		418 WCB2 146464AJ (514824)	
Item	Description	Part Number	Qty	Part Number	Qty	Part Number	Qty	Part Number	Qty
1	*Mounting Flange Sub Assy. (Includes Items 2,3,50 & 51)								
2	Mounting Flange								
3	Wear Plate								
6	Stud								
7	*Friction Disc sub Assy. (Item 8 & 9)								
8	Friction Block								
9	Friction Disc Core								
12	Clamp Tube								
13	*Pressure Platesub Assy. (Includes Items 3,14, 50 & 51)								
14	Pressure Plate								
17	Flat Washer								
18	Locknut								
19	Cylinder								
21	Polypak Seal								
23	Polypak Seal								
28	Gear (not included in assembly)								
29	Wear Spacer								
30	*Reaction Plate Sub Assy. (Includes Items 3, 31, 50 & 51)								
31	Reaction Plate								
33	Piston								
34	Release Spring								
50	Inner Support Ring								
51	Outer Support Ring								
57	Flat Head Screw								
105	Pipe Plug								

CONTACT AIRFLEX FOR DETAILS

\* - Individual parts breakdown for standard WCB2 subassemblies are in section 6.2.2

6.2 Parts (Corrosion Resistant)		124 WCB2 146465AJ (514825)		224 WCB2 146466AJ (514826)		324 WCB2 146467AJ (514827)		424 WCB2 146468AJ (514828)	
Item	Description	Part Number	Qty	Part Number	Qty	Part Number	Qty	Part Number	Qty
1	*Mounting Flange Sub Assy. (Includes Items 2,3,50 & 51)							514130-01	1
2	Mounting Flange							513337	1
3	Wear Plate							508459	8
6	Stud							308160-08	12
8	Friction Disc							508725	8
9	Friction Disc Core							514140	4
12	Clamp Tube							308206-08	12
13	*Pressure Platesub Assy. (Includes Items 3,14, 50 , 51 & 54)							514130-03	1
14	Pressure Plate							514044	1
17	Flat Washer							000153x0854	12
18	Locknut							000110x0076	12
19	Cylinder							514039	1
21	Polypak Seal							000402x0023	2
23	Polypak Seal							000402x0024	2
28	Gear (not included with assembly)							414343	1
29	Wear Spacer							308407	36
30	*Reaction Plate Sub Assy. (Includes Items 3, 31, 50, 51 & 54)							514130-02	3
31	Reaction Plate							514040	3
33	Piston							513924	1
34	Release Spring							416751-02	48
50	Inner Support Ring							413107	24
51	Outer Support Ring							413108	40
54	Pressure Plate Bushing							203866-01	12
	Reaction Plate Bushing							203866-04	36
57	Flat Head Screw							000421x0407	144
105	Pipe Plug							000077x0021	1
N/A	412 ES Molub-Alloy Lubricant							000153x1182	1

CONTACT AIRFLEX FOR DETAILS

\* - Individual parts breakdown for standard WCB2 subassemblies are in section 6.2.2

6.2 Parts (Corrosion Resistant)		136 WCB2 146469AJ (514829)		236 WCB2 146470AJ (514830)		336 WCB2 146471AJ (514831)		436 WCB2 146472AJ (514832)			
Item	Description	Part Number	Qty	Part Number	Qty	Part Number	Qty	Part Number	Qty		
1	*Mounting Flange Sub Assy. (Includes Items 2,3,50 & 51)					513284-01	1	513284-01	1		
2	Mounting Flange					513986	1	513986	1		
3	Wear Plate					416527	6	416527	6		
6	Stud					307111-05	16	307111-07	16		
7	Friction disc S/A					514129	3	514129	4		
8	Friction Block					513658	48	513658	64		
9	Friction Disc Core					514139	3	514139	3		
12	Clamp Tube					308204-04	16	308204-05	16		
13	*Pressure Platesub Assy. (Includes Items 3,14, 50 , 51& 54)	<b>CONTACT AIRFLEX FOR DETAILS</b>						513284-03	1	513284-03	1
14	Pressure Plate							513869	1	513869	1
17	Flat Washer							000153x0850	16	000153x0850	16
18	Locknut							000110x0075	16	000110x0075	16
19	Cylinder							512809	1	512809	1
21	Polypak Seal							000402x0005	2	000402x0005	2
23	Polypak Seal							000402x0006	2	000402x0006	2
28	Gear (not included with assembly)							416435	1	416495	1
29	Wear Spacer							308400	32	308400-05	48
30	*Reaction Plate Sub Assy. (Includes Items 3, 31, 50 , 51 & 54)									513284-02	3
31	Reaction Plate					512813	3	512813	4		
33	Piston					513872	1	513872	1		
34	Release Spring					416751-01	48	416751-01	64		
50	Inner Support Ring					414032-01	36	414032-01	48		
51	Outer Support Ring					414033-01	64	414033-01	72		
54	Pressure Plate Bushing					203863-04	16	203863-04	16		
	Reaction Plate Bushing					203863-03	32	203863-03	48		
57	Flat Head Screw					000421-0407	432	000421-0407	576		
105	Pipe Plug					000077x0021	1	000077x0021	1		
N/A	412 ES Molub-Alloy Lubricant					000153x1182	3	000153x1182	4		

\* - Individual parts breakdown for standard WCB2 subassemblies are in section 6.2.2

<b>6.2 Parts (Corrosion Resistant)</b>		<b>148 WCB2 146473 9600433)</b>		<b>248 WCB2 146474AJ (600434)</b>		<b>348 WCB2 146475AJ (600435)</b>		<b>448 WCB2 146476AJ (600436)</b>	
<b>Item</b>	<b>Description</b>	<b>Part Number</b>	<b>Qty</b>	<b>Part Number</b>	<b>Qty</b>	<b>Part Number</b>	<b>Qty</b>	<b>Part Number</b>	<b>Qty</b>
1	*Mounting Flange Sub Assy. (Includes Items 2,3,50 & 51)								
2	Mounting Flange								
3	Wear Plate								
6	Stud								
8	Friction Block								
9	Friction Disc Core								
12	Clamp Tube			<b>CONTACT AIRFLEX FOR DETAILS</b>					
13	*Pressure Platesub Assy. (Includes Items 3,14, 50, 51& 54)								
14	Pressure Plate								
17	Flat Washer								
18	Locknut								
19	Cylinder								
21	Polypak Seal								
23	Polypak Seal								
28	Gear (not included with assembly)								
29	Wear Spacer								
30	*Reaction Plate Sub Assy. (Includes Items 3, 31, 50 , 51 & 54)								
31	Reaction Plate								
33	Piston								
34	Release Spring								
50	Inner Support Ring								
51	Outer Support Ring								
54	Pressure Plate Bushing								
	Reaction Plate Bushing								
57	Flat Head Screw								
105	Pipe Plug								
N/A	412 ES Molub-Alloy Lubricant								

\* - Individual parts breakdown for standard WCB2 subassemblies are in section 6.2.2

## 6.2.2 Sub-assemblies (Corrosion Resistant)

6.2.2.1 Parts Breakdown of WCB2 Mounting Flange Sub-assemblies (Item Numbers (#) shown in Figure 1,2 & 21)						
Model ⇒	8 WCB2 Mounting Flange S/A	14 WCB2 Mounting Flange S/A	18 WCB2 Mounting Flange S/A	24 WCB2 Mounting Flange S/A	36 WCB2 Mounting Flange S/A	48 WCB2 Mounting Flange S/A
Part Description↓	Part No. (Qty)	Part No. (Qty)	Part No. (Qty)	Part No. (Qty)	Part No. (Qty)	Part No. (Qty)
<b>Sub Assembly Part #</b>	N/A			514130-01 (1)	513284-01 (1)	N/A
<b>Mounting Flange(2)</b>				513337 (1)	513986 (1)	
<b>Screw (4)</b>				000153x0685 (90)	000153x0842 (108)	
<b>Nut (5)</b>				000153x0856 (90)	000153x0844 (108)	
<b>Wear Plate (3)</b>				508459 (1)	416527 (1)	
<b>Inner Support Ring (50)</b>				413107 (3)	414032-01 (6)	
<b>outer support Ring (51)</b>				413108 (5)	414033-01 (9)	
<b>Hex Head Screw (4a)</b>				N/A	N/A	
<b>Inner O-ring (I)</b>				N/A	N/A	
<b>Outer O-ring (O)</b>				N/A	N/A	

6.2.2.2 Parts Breakdown of WCB2 Pressure Plate Sub-assemblies (Item Numbers (#) shown in Figure 1,2 & 21)						
Model ⇒	8 WCB2 Pressure Plate S/A	14 WCB2 Pressure Plate S/A	18 WCB2 Pressure Plate S/A	24 WCB2 Pressure Plate S/A	36 WCB2 Pressure Plate S/A	48 WCB2 Pressure Plate S/A
Part Description↓	Part No. (Qty)	Part No. (Qty)	Part No. (Qty)	Part No. (Qty)	Part No. (Qty)	Part No. (Qty)
<b>Sub Assembly Part #</b>	N/A			514130-03 (1)	513284-03 (1)	N/A
<b>Pressure Plate(14)</b>				514044 (1)	513869 (1)	
<b>Screw (4)</b>				000153x0685 (90)	000153x0842 (108)	
<b>Nut (5)</b>				000153x0856 (90)	000153X0844 (108)	
<b>Wear Plate (3)</b>				508459 (1)	416527 (1)	
<b>Inner Support Ring (50)</b>				413107 (3)	414032-01 (6)	
<b>outer support Ring (51)</b>				413108 (5)	414033-01 (9)	
<b>Hex Head Screw (4a)</b>				N/A	N/A	
<b>Inner O-ring (I)</b>				N/A	N/A	
<b>Outer O-ring (O)</b>				N/A	N/A	
<b>Bushing (54)</b>			203863-04 (12)	203866-01		

6.2.2.3 Parts Breakdown of WCB2 Reaction Plate Sub-assemblies (Item Numbers (#) shown in Figure 1,2 & 21)						
Model ⇒	8 WCB2 Reaction Plate S/A	14 WCB2 Reaction Plate S/A	18 WCB2 Reaction Plate S/A	24 WCB2 Reaction Plate S/A	36 WCB2 Reaction Plate S/A	48 WCB2 Reaction Plate S/A
Part Description↓	Part No. (Qty)	Part No. (Qty)	Part No. (Qty)	Part No. (Qty)	Part No. (Qty)	Part No. (Qty)
<b>Sub Assembly Part #</b>	<b>N/A</b>			513130-02 (1)	513985-02 (1)	<b>N/A</b>
<b>Reaction Plate (31)</b>				513040 (1)	513989 (1)	
<b>Screw (4)</b>				000153x0685 (90)	000153x0842 (108)	
<b>Nut (5)</b>				000153x0642 (90)	000153X0844 (108)	
<b>Wear Plate (3)</b>				508459 (1)	416527 (1)	
<b>Inner Support Ring (50)</b>				413107 (3)	414032-01 (6)	
<b>outer support Ring (51)</b>				413108 (5)	414033-01 (9)	
<b>Hex Head Screw (4a)</b>				N/A	N/A	
<b>Inner O-ring (I)</b>				N/A	N/A	
<b>Outer O-ring (O)</b>				N/A	N/A	
<b>Bushing (54)</b>				203866-04 (12)	203863-03 (16)	

6.2.2.4 Parts Breakdown of WCB2 Friction disc Sub-assemblies (Item Numbers (#) shown in Figure 1 & 2)						
Model ⇒	8 WCB2 Friction Disc S/A	14 WCB2 Friction Disc S/A	18 WCB2 Friction Disc S/A	24 WCB2 Friction Disc S/A	36 WCB2 Friction Disc S/A	48 WCB2 Friction Disc S/A
Part Description↓	Part No. (Qty)	Part No. (Qty)	Part No. (Qty)	Part No. (Qty)	Part No. (Qty)	Part No. (Qty)
<b>Sub Assembly Part #</b>					514129 (1)	
<b>Friction Disc (8)</b>					513658 (16)	
<b>Friction Disc Core(9)</b>					514139 (1)	
<b>Screw (57)</b>					000294x0407 (144)	
<b>Rivet (10)</b>					N/A	
<b>Washer (11)</b>					N/A	

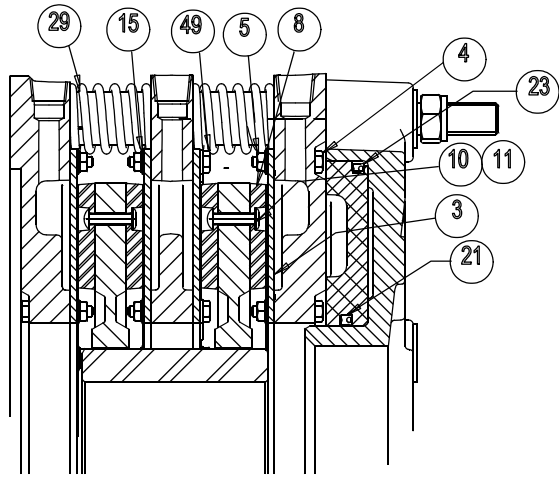

8 & 14 WCB2

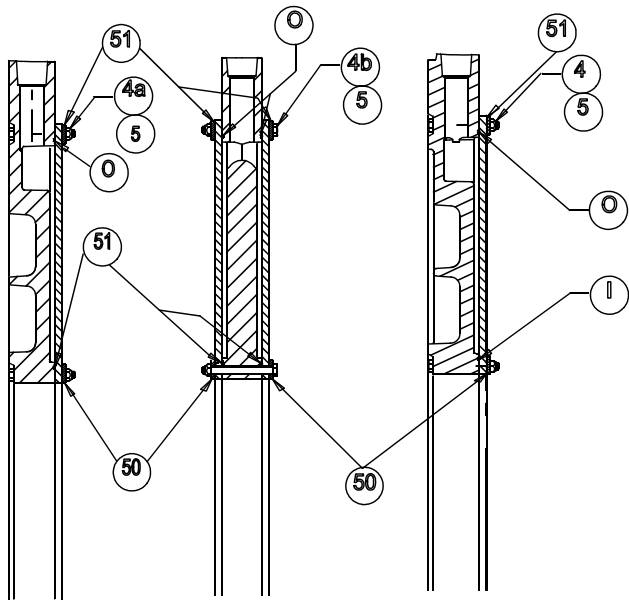

48 WCB2

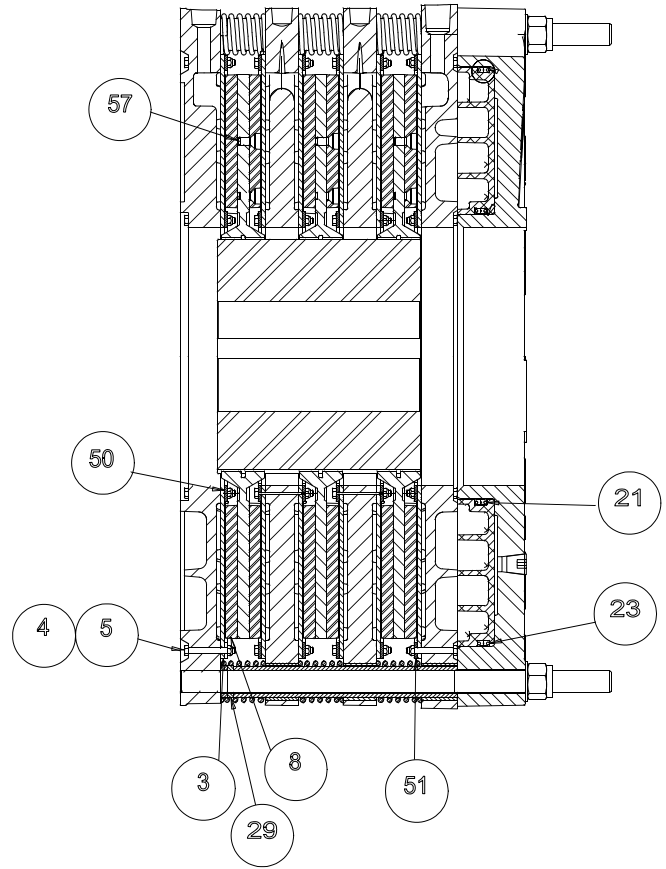

18, 24 & 36 WCB2

Figure 21

## 7.0 KITS

NOTE: Item Numbers (#) for Kits are shown on Figure 21

7.1 Friction Disc Kits (Standard)						
Parts included in kit>>>		Rivet (10)	Flat Washer (11)	Friction Disc (8)	Wear Spacer (29)	Instruction Sheet
Model	Kit P/N	Part No. (QTY)	Part No. (QTY)	Part No. (QTY)	Part No. (QTY)	Part No. (QTY)
108	107671B	000130x0086 (25)	000153x1065 (25)	512509 (2)	N/A	204063 (1)
208	107671BA	000130x0086 (50)	000153x1065 (50)	512509 (4)	308393 (6)	204063 (1)
308	107671BB	000130x0086 (75)	000153x1065 (75)	512509 (6)	308393 (12)	204063 (1)
114	107672B	000130x0085 (35)	000153x1064 (35)	415227 (2)	N/A	204064 (1)
214	107672BA	000130x0085 (70)	000153x1064 (70)	415227 (4)	308388-01 (6)	204064 (1)
314	107672BB	000130x0085 (105)	000153x1064 (105)	415227 (6)	308388-01 (12)	204064 (1)
Parts included in kit>>>		Loctite® #242 Sealant	Flat Head Screw (57)	Friction Disc (8)	Wear Spacer (29)	Instruction Sheet
118	107820B	000153x0923 (1)	000153x1147 (48)	513657 (2)	N/A	204097 (1)
218	107820BA	000153x0923 (1)	000153x1147 (96)	513657 (4)	308388-02 (12)	204097 (1)
318	107820BB	000153x0923 (2)	000153x1147 (144)	513657 (6)	308388-02 (24)	204097 (1)
418	107820BC	000153x0923 (2)	000153x1147 (192)	513657 (8)	308388-02 (36)	204097 (1)
Parts included in kit>>>		Loctite® #262 Sealant	Flat Head Screw (57)	Friction Disc (8)	Wear Spacer (29)	Instruction Sheet
124	107821B	000153x1016 (1)	000294x0407 (36)	508725 (2)	N/A	204097 (1)
224	107821BA	000153x1016 (2)	000294x0407 (72)	508725 (4)	308396 (12)	204097 (1)
324	107821BB	000153x1016 (3)	000294x0407 (108)	508725 (6)	308396 (24)	204097 (1)
424	107821BC	000153x1016 (4)	000294x0407 (144)	508725 (8)	308396 (36)	204097 (1)
136	107822B	000153x1168 (1)	000294x0407 (144)	513658 (16)	N/A	204097 (1)
236	107822BA	000153x1168 (2)	000294x0407 (288)	513658 (32)	308397 (16)	204097 (1)
336	107822BB	000153x1168 (3)	000294x0407 (432)	513658 (48)	308397 (32)	204097 (1)
436	107822BC	000153x1168 (4)	000294x0407 (576)	513658 (64)	308397 (48)	204097 (1)
148	108058B	000153x1168 (2)	000294x0407 (224)	514286 (16)	N/A	204097 (1)
248	108058BA	000153x1168 (3)	000294x0407 (448)	514286 (32)	308398 (16)	204097 (1)
348	108058BB	000153x1168 (5)	000294x0407 (672)	514286 (48)	308398 (32)	204097 (1)
448	108058BC	000153x1168 (6)	000294x0407 (896)	514286 (64)	308398 (48)	204097 (1)

### 7.2 Friction Disc Kits (Corrosion)

Parts included in kit		Loctite® #262	Flat Head Screw (57)	Friction Disc (8)	412ES Moluballoy	Wear Spacer (29)	Instruction Sheet
Model	Kit P/N	Part No. (QTY)	Part No. (QTY)	Part No. (QTY)	Part No. (QTY)	Part No. (QTY)	Part No. (QTY)
124	107821C	000153x1016 (1)	000421x0407 (36)	508725 (2)	000153x1182 (1)	N/A	204130 (1)
224	107821CA	000153x1016 (2)	000421x0407 (72)	508725 (4)	000153x1182 (1)	308824 (12)	204130 (1)
324	107821CB	000153x1016 (3)	000421x0407 (108)	508725 (6)	000153x1182 (1)	308824 (24)	204130 (1)
424	107821CC	000153x1016 (4)	000421x0407 (144)	508725 (8)	000153x1182 (1)	308824 (36)	204130 (1)
136	107822C	000153x1168 (1)	000421x0407 (144)	513658 (16)	000153x1182 (1)	N/A	204130 (1)
236	107822CA	000153x1168 (2)	000421x0407 (288)	513658 (32)	000153x1182 (1)	308425 (16)	204130 (1)
336	107822CB	000153x1168 (3)	000421x0407 (432)	513658 (48)	000153x1182 (1)	308425 (32)	204130 (1)
436	107822CC	000153x1168 (4)	000421x0407 (576)	513658 (64)	000153x1182 (4)	308425 (48)	204130 (1)
148	108058C	<b>Contact Airflex for details</b>					
248	108058CA						
348	108058CB						
448	108058CC						

### 7.3 Cylinder Seal Kits

Parts included in kit		Dow Corning (R) 55 O-ring Lube	Lip Seal (Inner) (21)	Lip Seal (Outer) (23)	Instruction Sheet
Model	Kit P/N	Part No. (QTY)	Part No. (QTY)	Part No. (QTY)	Part No. (QTY)
8	107671C	000153x1239 (1)	000402x0001 (1)	000402x0002 (1)	204067 (1)
14	107672C	000153x1239 (1)	000402x0003 (1)	000402x0004 (1)	204067 (1)
18	107726C	000153x1239 (1)	000402x0021 (2)	000402x0022 (2)	204067 (1)
24	107727C	000153x1239 (1)	000402x0023 (2)	000402x0024 (2)	204067 (1)
36	107662C	000153x1239 (1)	000402x0005 (2)	000402x0006 (2)	204067 (1)
48	108055C	000153x1239 (1)	000402x0042 (2)	000402x0044 (2)	204067 (1)

### 7.4 Wear Plate Kits for Mounting Flange and Pressure Plate

Parts included in kit		Screw (4)	Flair Nut (5)	Loctite #596	Instruction Sheet	Wear Plate (3)	Inner Support Ring (50)	Outer Support Ring (51)
Model	Kit P/N	Part No. (QTY)	Part No. (QTY)	Part No. (QTY)	Part No. (QTY)	Part No. (QTY)	Part No. (QTY)	Part No. (QTY)
8	107671A	000030x5407 (84)	000153x1049 (84)	000153x1071 (1)	204063 (1)	512507 (2)	N/A	N/A
14	107672A	000153x1017 (120)	000153x1061 (120)	000153x1071 (1)	204063 (1)	415212 (2)	N/A	N/A
18	107727A	000153x0642 (160)	000153x0726 (160)	000153x1071 (1)	204063 (1)	412953 (2)	413105 (8)	413106 (8)
24	107727A	000153x0642 (180)	000153x0685 (180)	000153x1071 (1)	204063 (1)	508459 (2)	413107 (6)	413108 (10)
36	107662A	000153x0842 (216)	000153x0844 (216)	000153x1071 (2)	204063 (1)	416527 (2)	414032-01 (12)	414033-01 (18)

Parts included in kit		Inner O-Ring (I)	Outer O-Ring (O)	Hex Head Screw (4)	Locknut (5)	Loctite #596	Hex Head Screw (4a)	Instruction Sheet	Inner Support Ring(50)	Outer Support Ring (51)	Wear Plate (3)
Model	Kit P/N	Part No. (QTY)	Part No. (QTY)	Part No. (QTY)	Part No. (QTY)	Part No. (QTY)	Part No. (QTY)	Part No. (QTY)	Part No. (QTY)	Part No. (QTY)	Part No. (QTY)
48	108055A	000073x0410 (2)	000073x0411 (2)	000153x0843 (120)	000153x0844 (240)	000153x1071 (3)	000153x1223 (120)	204063 (1)	416618 (10)	416673 (20)	416690 (2)

### 7.5 Wear Plate Kits for Reaction Plate

Parts included in kit		Screw (49)	Washer (15)	Nut (5)	Loctite #596	Instruction Sheet	Wear Plate (3)	Inner Support Ring (50)	Outer Support Ring (51)
Model	Kit P/N	Part No. (QTY)	Part No. (QTY)	Part No. (QTY)	Part No. (QTY)	Part No. (QTY)	Part No. (QTY)	Part No. (QTY)	Part No. (QTY)
8	107671E	000030x5408 (42)	000067x0036 (42)	000153x1049 (42)	000153x1071 (1)	204063 (1)	512507 (2)	N/A	N/A
14	107672E	000153x1018 (60)	000067x0001 (60)	000153x1061 (60)	000153x1071 (1)	204063 (1)	415212 (2)	N/A	N/A
18	107727A	000153x0642 (80)	N/A	000153x0685 (80)	000153x1071 (1)	204063 (1)	412953 (2)	413105 (8)	413106 (8)
24	107727A	000153x0642 (90)	N/A	000153x0685 (90)	000153x1071 (1)	204063 (1)	508459 (2)	413107 (6)	413108 (10)
36	107662A	000153x0842 (108)	N/A	000153x0844 (108)	000153x1071 (2)	204063 (1)	416527 (2)	414032-01 (12)	414033-01 (18)

Parts included in kit		Inner O-Ring (I)	Outside O-Ring (O)	Screw (4b)	Locknut (5)	Loctite #596	Instruction Sheet	Inner Support Ring (50)	Outer Support Ring (51)	Wear Plate (3)
Model	Kit P/N	Part No. (QTY)	Part No. (QTY)	Part No. (QTY)	Part No. (QTY)	Part No. (QTY)	Part No. (QTY)	Part No. (QTY)	Part No. (QTY)	Part No. (QTY)
48	108055A	000073x0410 (2)	000073x0411 (2)	000153x1224 (120)	000153x0844 (120)	000153x1071 (3)	204063 (1)	416618 (10)	416673 (20)	416690 (2)

## **EATON PRODUCT WARRANTY**

Subject to the conditions stated herein, Eaton Corporation warrants to the Purchaser that each new Airflex Product manufactured by Eaton will be free from failures caused by defects in material and workmanship, and will deliver its rated capacity, for a period of twelve (12) months from the date of shipment to Purchaser, provided such Product is properly installed, properly maintained, operated under normal conditions and with competent supervision. Warranty claims shall be made in writing and the part or parts shall, if requested by Airflex Division, be returned prepaid to the Airflex Division for inspection. Upon a determination that a defect exists, Eaton shall thereupon correct any defect, at its option either by repairing any defective part or parts or by making available at Eaton's plant a repaired or replacement part. This warranty does not extend to normal wear parts or components of the Product, such as friction material and friction surfaces.

## **LIMITATION OF WARRANTY**

THE FOREGOING WARRANTY IS EXCLUSIVE AND IN LIEU OF ALL OTHER WARRANTIES WHETHER WRITTEN, ORAL OR IMPLIED. ANY IMPLIED WARRANTY OF MERCHANTABILITY OR FITNESS FOR A PARTICULAR PURPOSE ARE SPECIFICALLY EXCLUDED.

In no event shall Eaton be liable for special, incidental or consequential damages. Eaton's liability arising out of the supplying of such Product, or its use, whether in warranty, contract or otherwise, shall in no case exceed the cost of correcting defects in the Products as herein provided. Upon expiration of the twelve (12) month period, all such liability shall terminate. THE FOREGOING SHALL CONSTITUTE THE SOLE REMEDY OF PURCHASER AND THE SOLE LIABILITY OF EATON.