

**DBB 8100**



**Warning**

Forward this manual to the person responsible for Installation, Operation and Maintenance of the product described herein. Without access to this information, faulty Installation, Operation or Maintenance may result in personal injury or equipment damage.

# Installation, Operation and Maintenance of Airflex® Model DBB Brake Assemblies



**Caution:**

**Use Only Genuine Airflex® Replacement Parts**

The Airflex Division of Eaton Corporation recommends the use of genuine Airflex replacement parts. The use of non-genuine Airflex replacement parts could result in substandard product performance, and may void your Eaton warranty. For optimum performance, contact Airflex:

In the U.S.A. and Canada: **1-800 AIRFLEX (247-3539)**

U.S.A. and Canada: **(216) 281-2211**

Internet: **www.airflex.com**

**October, 1990**

(Revised: August, 2001)

**204045**

© Copyright Eaton Corp., 2001. All rights reserved.

**Authorized Distributor**

26255 Groesbeck Hwy.  
Warren, MI 48089 U.S.A.  
586.775.3000 • 586.775.3040 (Fax)  
sales@midwestbrake.com  
www.midwestbrake.com

**Eaton® Airflex® Clutches & Brakes**

## Table of Contents

1.0	INTRODUCTION . . . . .	4
1.1	Description . . . . .	4
1.2	How it Works . . . . .	4
2.0	INSTALLATION . . . . .	4
2.1	Preparation . . . . .	4
2.2	Mounting . . . . .	5
2.3	Air Supply System . . . . .	6
3.0	OPERATION . . . . .	7
3.1	Pressure and Speed Limits . . . . .	7
3.2	Initial Operation . . . . .	7
3.3	Periodic Maintenance . . . . .	7
4.0	MAINTENANCE . . . . .	8
4.1	Wear Limits . . . . .	8
4.2	Friction Disc Replacement . . . . .	8
4.3	Air Manifold Repair . . . . .	11
4.4	Cylinder Seal Replacement . . . . .	12
4.5	Spring Replacement . . . . .	12
5.0	ORDERING INFORMATION/TECHNICAL ASSISTANCE . . . . .	14
6.0	PARTS LISTS . . . . .	15-19

**FIGURE 1**

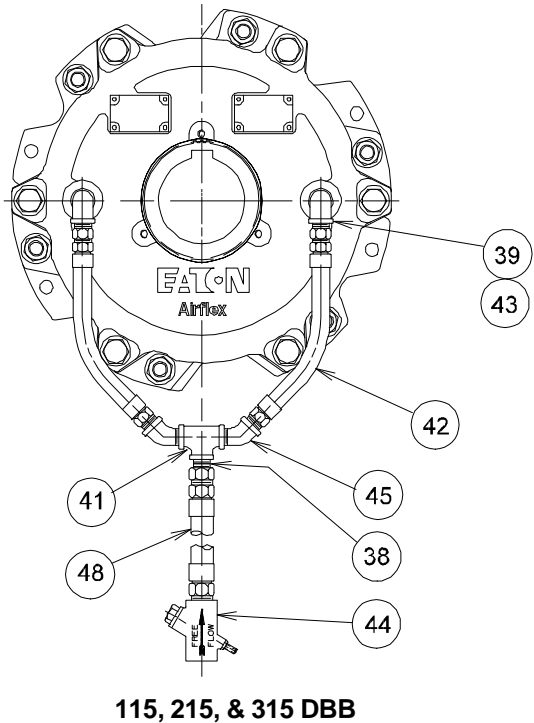
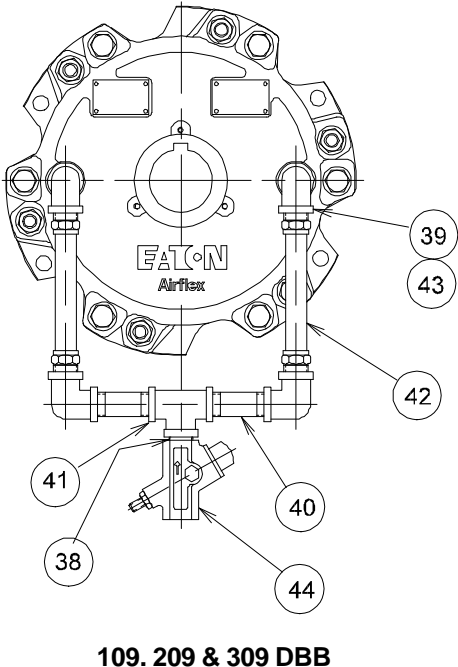
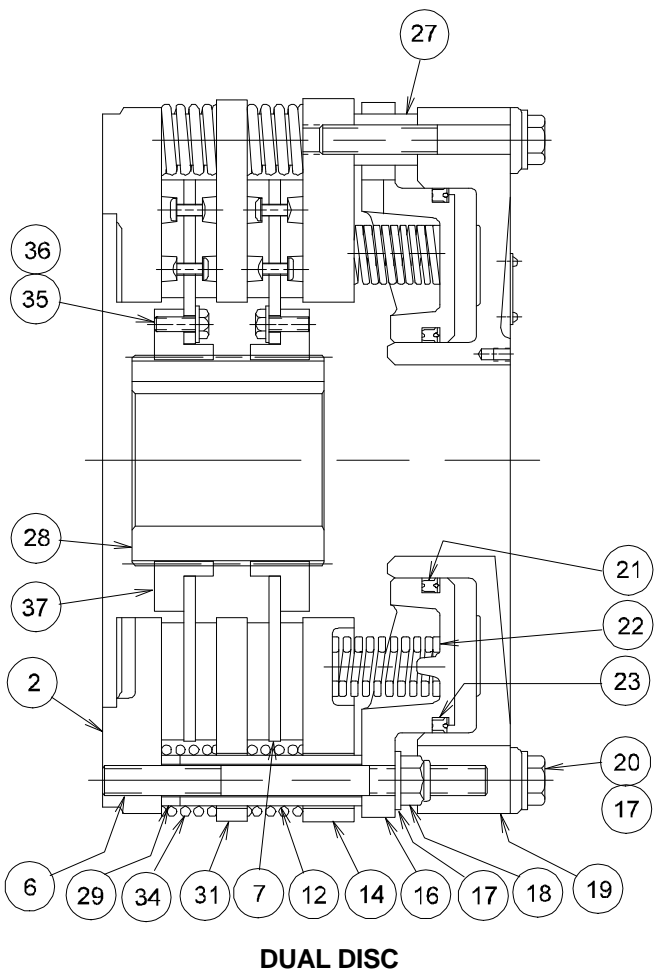
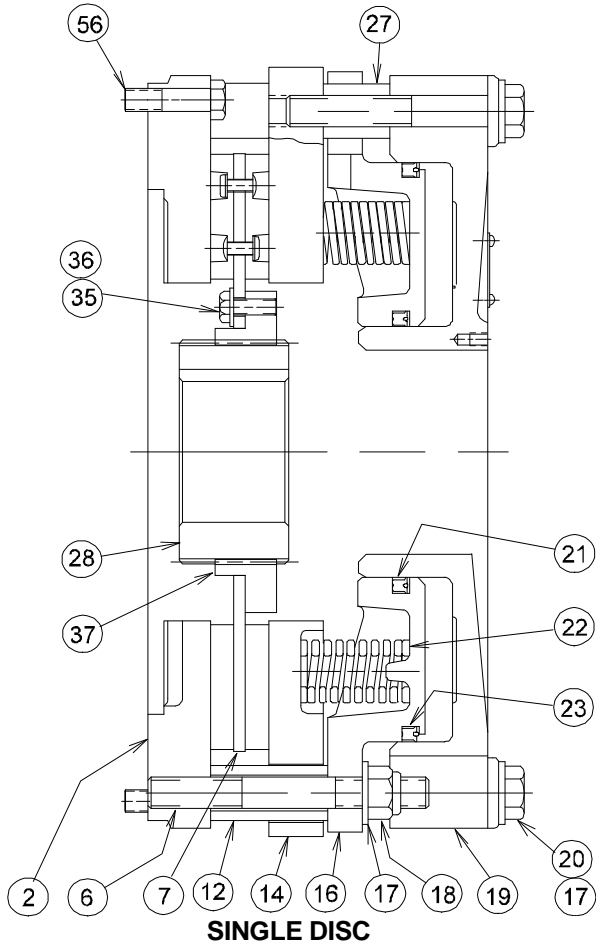

**FIGURE 1**  
Continued

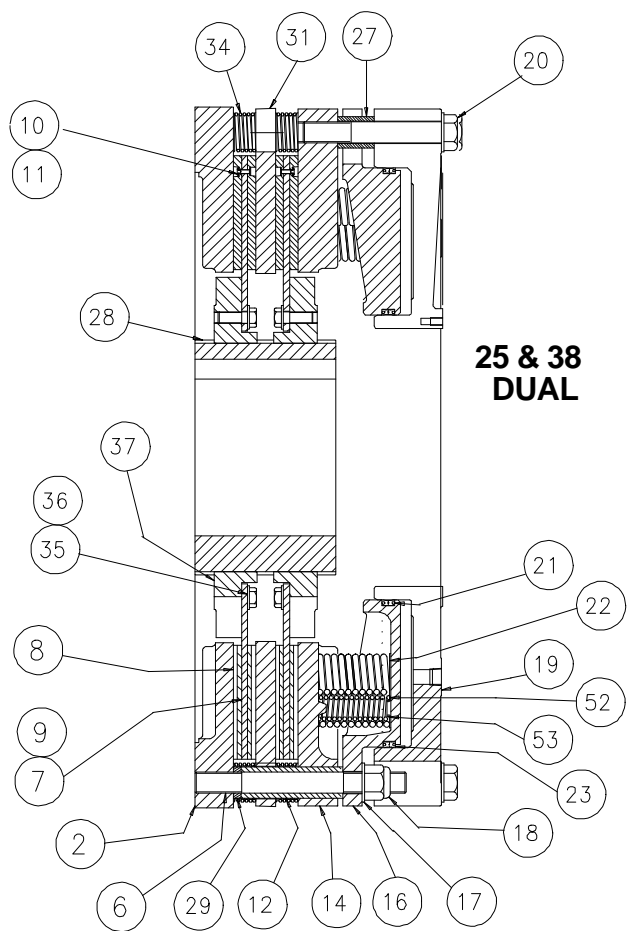
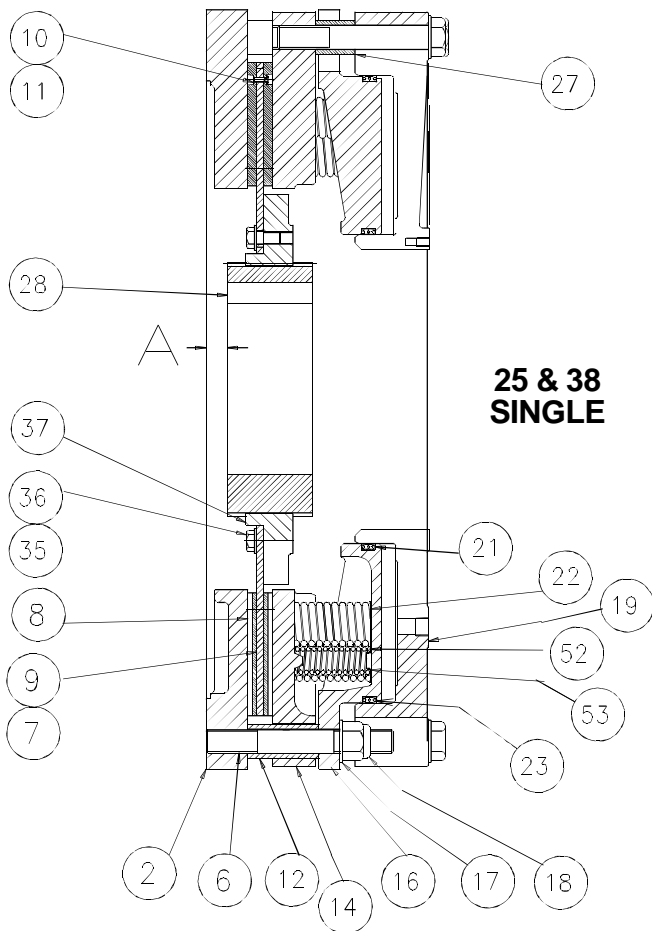
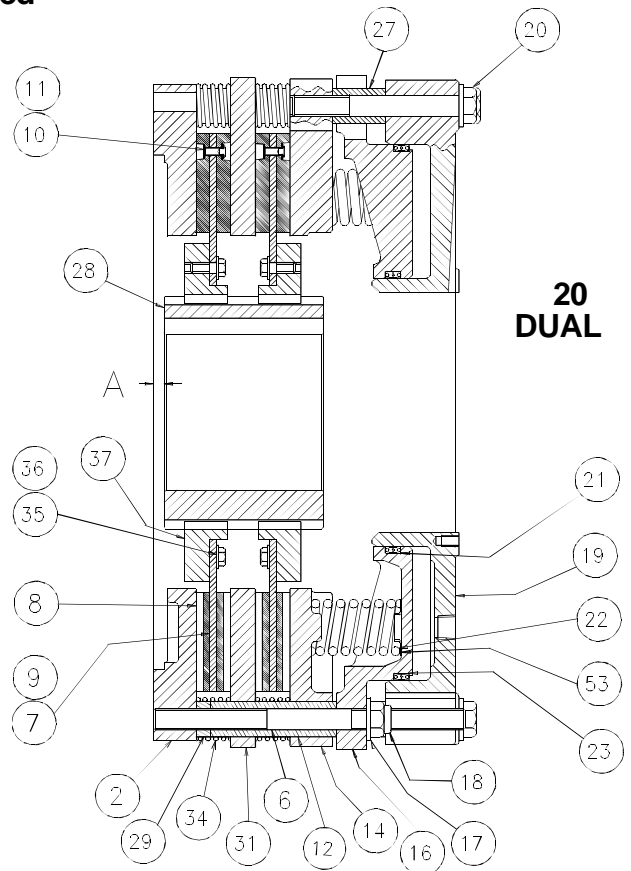
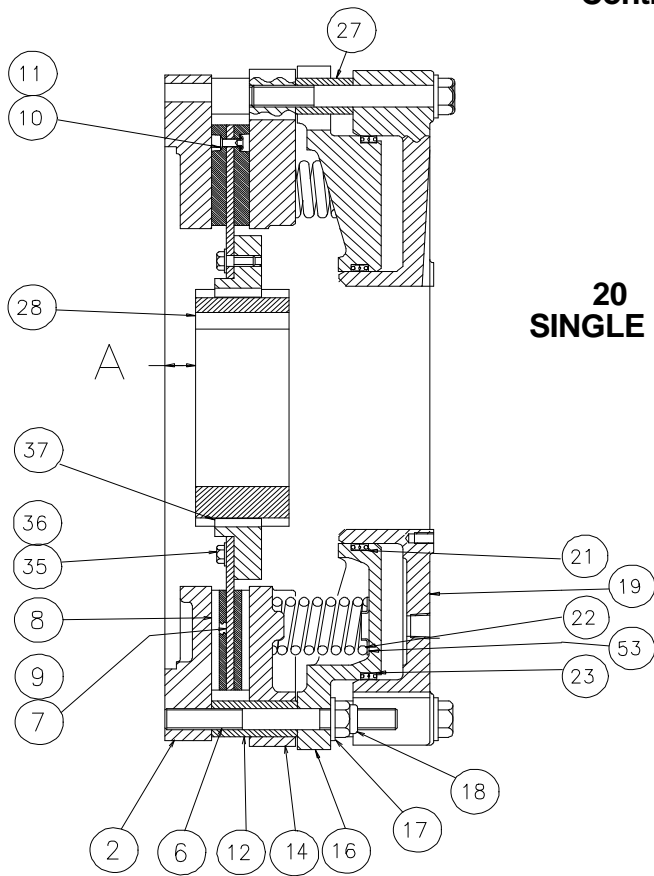

**Figure 1  
Continued**

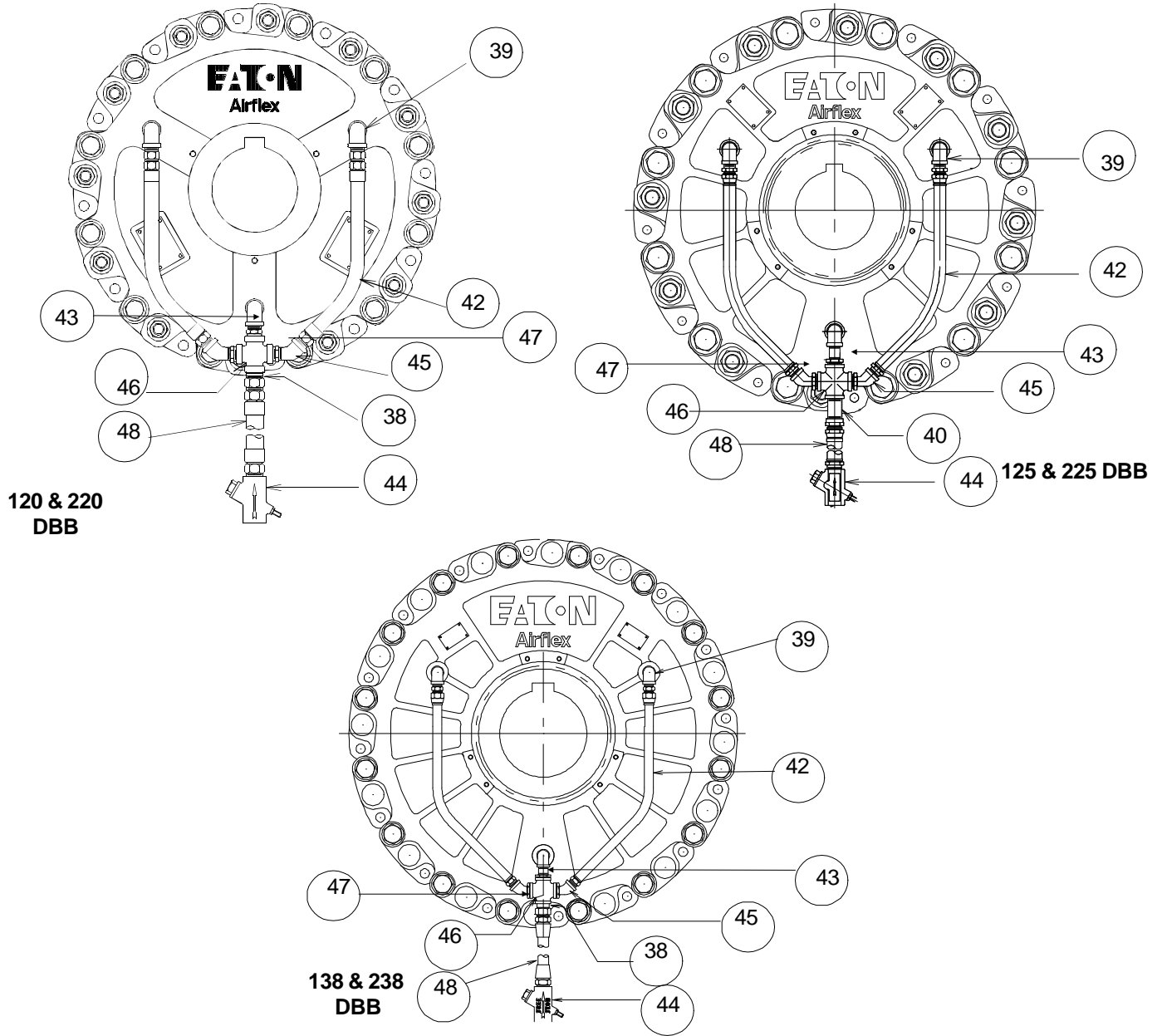

Item	Description	Item	Description	Item	Description
2	Mounting Flange	23	Polypak Seal	41	Reducing Tee
6	Stud	27	Spacer Tube	42	Hose Assembly
7	Friction Disc Assembly	28	Gear	43	Pipe Nipple
12	Clamp Tube	29	Wear Spacer	44	Flow Control Valve
14	Pressure Plate	31	Reaction Plate	45	45° Street Elbow
16	Spring Housing	34	Release Spring	46	Pipe Cross
17	Flat Washer	35	Washer	47	Pipe Reducer
18	Locknut	36	Hex Head Screw	48	Hose Assembly
19	Cylinder	37	Ring Gear	52	Inner Spring
20	Hex Head Screw	38	Pipe Nipple	53	Spring Retainer
21	Polypak Seal	39	Elbow	56	Hex Head Cap Screw
22	Spring	40	Pipe Nipple		

# 1.0 INTRODUCTION

Throughout this manual there are a number of **HAZARD WARNINGS** that must be read and adhered to in order to prevent possible personal injury and/or damage to the equipment. Three signal words “**DANGER**”, “**WARNING**”, and “**CAUTION**” are used to indicate the severity of the hazard, and are preceded by the safety alert symbol 



**Danger:**

**Denotes the most serious injury hazard, and is used when serious injury or death WILL result from misuse or failure to follow specific instructions.**



**Warning:**



**Used when serious injury or death MAY result from misuse or failure to follow specific instructions.**



**Caution:**

**Used when injury or product/equipment damage may result from misuse or failure to follow specific instructions.**

It is the responsibility and the duty of all personnel involved in the installation, operation and maintenance of the equipment on which this device

is used to fully understand the  **DANGER**,  **WARNING**, and  **CAUTION** procedures by which hazards are to be avoided.

## 1.1 Description

- 1.1.1 The Airflex Model DBB brakes were designed for heavy duty industrial applications where spring set (power off) braking is required.
- 1.1.2 All Airflex DBB brakes are supplied with long wearing, NON-ASBESTOS friction material.
- 1.1.3 Airflex DBB brakes are available in five basic sizes and can be supplied as single or dual disc units.

## 1.2 How it Works

- 1.2.1 Referring to Figure 1, the gear (28) is mounted on the shaft which is to be stopped and the brake assembly is attached to the machine frame or a reaction bracket. As air pressure is applied

through the ports in the cylinder (19), the cylinder and pressure plate (14), which are attached to each other with screws (20), flat washers (17) and spacer tubes (27), move away from the mounting flange (2), which is connected to the machine frame or reaction bracket. The pressure plate compresses the springs (22) against the stationary spring housing (16) and the clamp force is removed from the friction disc assembly (7,35,36,37) which rides on the gear. The shaft is then free to rotate. As air pressure is exhausted, the springs force the pressure plate toward the mounting flange, clamping the friction disc assembly between the two members. On dual disc models, an additional friction disc assembly and a reaction plate (31) are clamped between the pressure plate and mounting flange.

# 2.0 INSTALLATION

## 2.1 Preparation

- 2.1.1 Table 1 shows the relationship between the brake mounting surface and the end of the gear (dimension “A” on Figure 1). The gear is bored and keyed for a resulting Class FN2S interference fit for inch shafting and ISO System S7h6 for metric shafting.

TABLE 1		
“A” Dimensions on Figure 1 in. (mm)		
Brake Size	Single Disc	Dual Disc
9DBB	0.50 (13)	0.25 (6)
15DBB	0.38 (10)	0.38 (10)
20DBB	1.00 (25.4)	0.38 (10)
25DBB	0.75 (19)	0.38 (10)
38DBB	1.25 (31.4)	0.00 (0)

- 2.1.2 Figure 2 and Table 2 show the mounting dimensions for the brake to the machine frame or reaction bracket. Note that a male or female register may be used.

TABLE 2		
Brake Mounting Register Diameters in. (mm)		
Brake Size	Female Register*	Male Register
9DBB	8.375 (212.7)	12.125/12.122 (308.0/307.9)
15DBB	14.375 (365.1)	18.375/18.370 (466.7/466.6)
20DBB	18.250 (463.55)	N/A
25DBB	24.375 (619.125)	N/A
38DBB	36.375 (923.9)	N/A

\* +.003 (.08)/-.000  
Registers to be .125" - .250" (3.2 - 6.35 mm) deep.

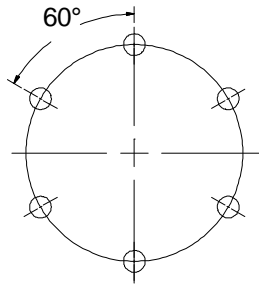

**9 DBB**

(6) 0.531" (13.5)Ø Mounting holes equally spaced, spaced as shown on 11.125" (282.5) bolt circle.

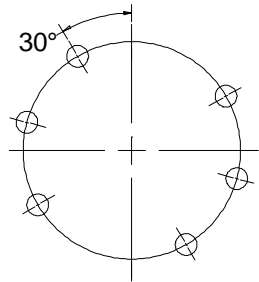

**15 DBB**

(6) 0.656" (16.7)Ø Mounting holes based on 8 equally spaced as shown on 17.500" (444.5) bolt circle.

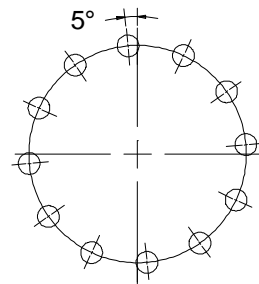

**20 DBB**

(12) 0.656" (16.7)Ø Mounting holes equally spaced as shown on 22.000" (558.8) bolt circle.

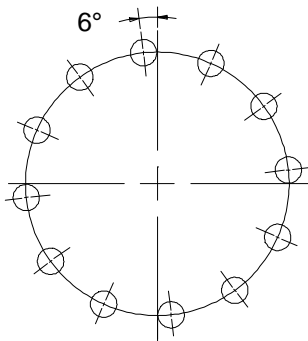

**25 DBB**

(12) 0.656" (16.7)Ø Mounting holes equally spaced as shown on 28.750"(730.3) bolt circle.

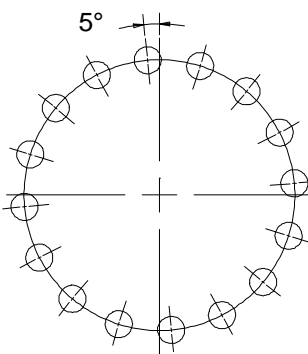

**38 DBB**

(16) 1.062(27.0)Ø Mounting holes equally spaced as shown on 42.000 (1066.8) bolt circle.

**2.1.3 Alignment**

2.1.3.1 For proper operation and service life, the brake reaction member must be aligned to the shaft within the limits shown on Table 3.

Brake Size	Concentricity of Shaft and Brake in. (mm)	Perpendicularity of Mounting Flange (1) to Shaft in. (mm)
9DBB	0.005 (0.13)	0.005 (0.13)
15DBB	0.010 (0.25)	0.007 (0.18)
20DBB	0.010 (0.25)	0.010 (0.25)
25DBB	0.010 (0.25)	0.012 (0.30)
38DBB	0.010 (0.25)	0.019 (.048)

Perpendicularity referenced to outside diameter of mounting flange from shaft center line (TIR).



Proper alignment is necessary to assure the friction discs track properly. Improper alignment will result in excessive wear to the friction material and its mating surfaces, gear and ring gear (37). See Figure 3.

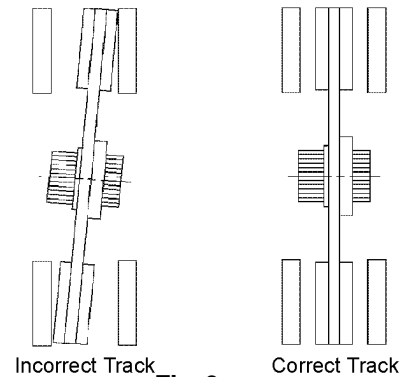

**Fig. 3**

**2.2 Mounting**

- 2.2.1 Ensure the shaft is free of nicks or burrs and the key fits properly in the shaft and gear. Tap the key into the shaft keyway.
- 2.2.2 Apply a light coat of anti-seizing compound to the shaft.
- 2.2.3 Press the gear onto the shaft, making sure the dimension between the gear and the brake mounting surface ("A") is maintained. See Figure 1 and Table 1. Heating the gear uniformly to approximately 200°F will expand the bore and ease assembly.

Note: On dual disc brakes, before installing the gear onto the shaft, slide it into the brake assembly to align the splines on the friction disc assemblies. Air pressure must be applied to the brake to release the friction disc assemblies for alignment. Once the gear passes through both friction disc assemblies, exhaust the air to clamp them into position and remove the gear.



**Warning:**

**Maximum allowable air pressure is 120 psig (8.2 bar). Application of pressure exceeding maximum allowable may result in damage to the brake.**

- 2.2.4 Apply a light coat of Molub-Alloy OG Heavy grease to the gear teeth and slide the brake assembly onto the gear.
- 2.2.5 While supporting the brake, connect an air supply and apply enough pressure to release the brake. Attach the mounting flange (2) to the brake mounting surface using the appropriate fasteners. Torque the fasteners to the specified value. See Table 4.



**Danger:**

**Use only the proper number and grade fasteners shown in Table 4. Use of commercial grade (Grade 2) fasteners where Grade 8 fasteners are specified may result in failure of the fasteners and a sudden and drastic reduction in brake torque.**

Note: On 115DBB and 215DBB brakes, two fasteners are pre-assembled in the mounting flange.

## 2.3 Air Supply System



**Warning:**

**Maximum allowable air pressure is 120 psig (8.2 bar). Operation of the DBB at pressures exceeding 120 psig may result in damage to the brake components.**



**Caution:**

**Minimum releasing pressure for low pressure brakes is 60 psig (4.1 bar). Operation at pressures below minimum will result in brake drag and excessive heat and wear.**

- 2.3.1 Since the air control arrangement will vary from one application to the next, a specific description cannot be presented here. Following are some general guidelines for installing the air control components.
  - 2.3.1.1 Use full-size piping consistent with the solenoid valve size as shown on Table 5.

Brake Size	Pipe Size NPT
9DBB	1/2-14
15DBB	3/4-14
20DBB	3/4-14
25DBB	3/4-14
38DBB	1-11

- 2.3.1.2 Keep the number of elbows to a minimum to ensure consistent brake response.

Fastener		9DBB	15DBB	20DBB	25DBB	38DBB
Item #18	Description	1/2-13NC-3	3/4-10NC-3	3/4-10NC-3	1-1/8-7NC-3	1 3/8-6NC-3
	Torque	60 (81)	150 (203)	150 (203)	500(677)	750 (1015)
Item #20	Description	1/2-13NC-2 Gr. 8	3/4-10NC-2 Gr. 8	3/4-10NC-2 Gr. 8	1 1/8-7NC-2Gr.8	1 3/8-6NC-2Gr. 8
	Torque	60 (81)	150 (203)	150 (203)	500(677)	750 (1015)
Item #36	Description	1/4-20NC-2 Gr. 8	3/8-16NC-2 Gr. 8	3/8-16NC-2 Gr. 8	1/2-13NC-2Gr.8	3/4-10NC-2 Gr. 8
	Torque	12 (16)	40 (54)	40 (54)	70 (95)	200 (271)
Mounting Screw	Description	1/2-13NC-2 Gr. 8	5/8-11NC-2 Gr. 8	5/8-11NC-2 Gr. 8	5/8-11NC-2 Gr. 8	1-8NC-2 Gr. 8
	Torque	70 (95)	138 (187)	138 (187)	138 (187)	500 (677)

- 2.3.1.3 Spool type solenoid valves are not recommended. Use only poppet type valves if possible, and locate the solenoid valve as close as possible to the brake.



**Warning:**

**If the DBB brake is being used on a mechanical power press, special valving may be required.**

- 2.3.1.4 If the DBB brake is being used on a cyclic application, an air receiver tank should be installed in the air supply line and isolated (check valve) from other air consuming equipment.
- 2.3.1.5 The final connection to the brake inlet ports must be made with flexible hose.
- 2.3.1.6 The DBB brake does not require lubricated air however the solenoid valve may. Consult the valve manufacturer.
- 2.3.1.7 A pressure switch should be located in the air, supply line to the brake and interlocked with the equipment electrical controls.

### 3.0 OPERATION

#### 3.1 Pressure and Speed Limits

- 3.1.1 Maximum applied pressure is 120 psig (8.2 bar). Minimum releasing pressure for low pressure brakes is 60 psig (4.1 bar).



**Warning:**

**Maximum applied pressure is 120 psig (8.2 bar). Operation at pressures exceeding maximum may result in damage to the DBB components.**

- 3.1.2 Maximum disc speeds are shown on Table 6.



**Warning:**

**Operation at disc speeds exceeding the maximum allowable, as shown on Table 6, may result in exposure to personal injury or product/equipment damage.**

TABLE 6	
Maximum Disc Speed	
Brake Size	Max. Disc. Speed rpm
9DBB	3000
15DBB	2400
20DBB	1800
25DBB	1400
38DBB	950

### 3.2 Initial Operation

- 3.2.1 The non-asbestos friction material used on DBB brakes may not develop rated torque as a short wear in period is required.
- 3.2.2 If the brake engagement appears harsh, a flow control valve (44) may be installed in the brake air supply line. When using a flow control valve, install so free flow is to the brake and restricted flow is away from the brake. Figure 1 shows the flow control valves and Airflex part numbers for each size DBB brake can be found in the Parts List.



**Caution:**

**Excessive restriction of the brake exhaust air will result in long stopping times and inconsistent stopping position.**

- 3.2.3 If the DBB brake is used in combination with a clutch, clutch/brake overlap may occur which will result in excessive heat generation and motor overload. Overlap may be detected by monitoring the drive motor current at the beginning and end of each machine cycle. A current surge at the beginning of the cycle usually indicates clutch overlap which can be corrected by restricting the air flow to the clutch or increasing the air pressure to the brake. A current surge at the end of the machine cycle usually indicates brake overlap which can be corrected by installing and adjusting a flow control valve in the brake air supply line, as indicated in 3.2.2. Figure 4 illustrates clutch and brake overlap.

### 3.3 Periodic Inspection

- 3.3.1 As the friction material wears, the brake torque will be reduced somewhat and adjustment of the stopping position controls (flow control or limit switch) will be necessary. See the MAINTENANCE section for the friction material wear limit and replacement procedure.

## TYPICAL MOTOR AMPERE CURVE

SOLID LINE - NORMAL CURRENT FLUCTUATIONS DURING COMPLETE CYCLE  
 DOTTED LINE - ABNORMAL CURRENT SURGES INDICATING OVERLAP

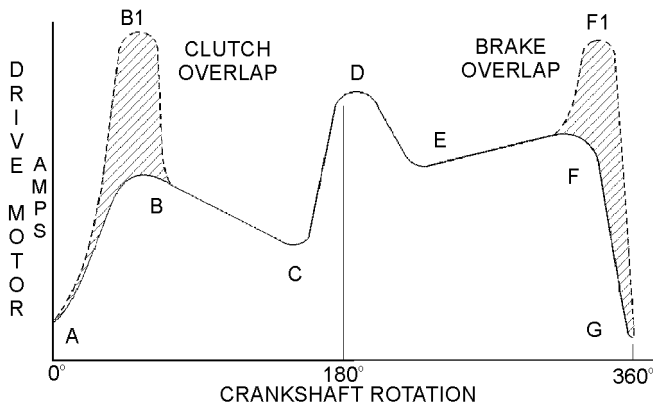

- A-B Normal Motor Amp Surge - During Acceleration
- A-B1 Abnormal Surge Indicates Clutch Overlap
- B-C Ram on Downstroke - Motor Amps Drop
- C-D Ampere Surge as Dies Make Contact
- E-F Ram Moving up Back stroke
- F-G Clutch Release Brake Set - Normal Drop to No Load AMPS

Fig. 4

- 3.3.2 Periodically check for air leakage in the area of the piston seals (21,23). For replacement, refer to the MAINTENANCE section.
- 3.3.3 Periodically observe the friction disc assembly(s) with the brake released. Dragging friction discs may be caused by wear or contamination at the gear/ring gear contact areas.
- 3.3.4 Pneumatic and electrical control interlocks should be periodically checked for correct settings and operation.

## 4.0 MAINTENANCE



**Warning:**

**Prior to performing any maintenance on the DBB brake, make sure the equipment is in, and will remain in, a safe condition.**

### 4.1 Wear Limits

- 4.1.1 Wear limits for the DBB components are shown on Table 8. If any wear limit has been reached or exceeded, that component must be repaired or replaced.

## 4.2 Wear Adjustment

- 4.2.1 On single and dual disc units, the friction material must be replaced when worn to the bottom of the groove on the friction lining. See Figure 5. On dual disc brakes, however, a wear adjustment is required when the friction material is approximately one-half worn. To determine when adjustment is required, measure the gap between the spring housing (16) and the pressure plate (14) with the brake engaged, as shown on Figure 6. When this dimension is X (from Table 7) or greater, AND none of the friction discs are worn to the bottom of the wear groove adjust per the following procedure.

DBB	209	215	220	225	238	
X	in.	.500	.500	.640	.680	.812
	(mm)	(12.7)	(12.7)	(16.26)	(17.27)	(20.62)
New		.120	.120	.140	.150	.312

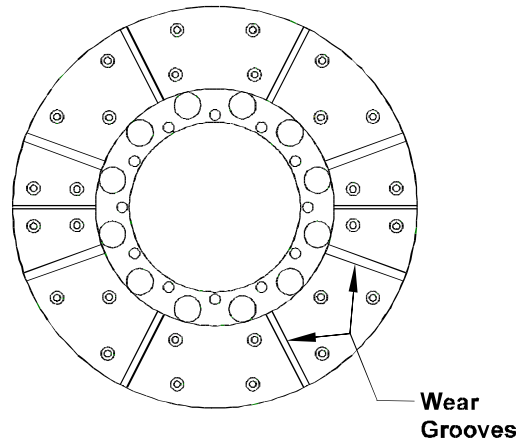

Fig. 5

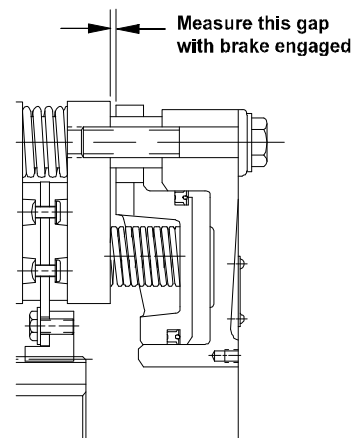

Fig.6

<b>TABLE 8</b>			
<b>Wear Limits for DBB Brake Components</b>			
<b>Item</b>	<b>Description</b>	<b>Wear Limit</b>	<b>Remarks</b>
#7 Friction Disc Assembly	Friction Material	Fully worn at bottom of dust groove. See Figure 5. Friction material must also be replaced when contaminated with oil or grease.	Dual disc brakes have adjustment provision. See 4.2.1.
#1 Mounting Flange	Friction Wear Surface	Maximum wear is .031 in. (.80 mm).	Wear will be in form of circular grooves on iron surface.
#13 Pressure Plate	Friction Wear Surface	Maximum wear is .031 in. (.80 mm).	Wear will be in the form of circular grooves on iron surface.
	Reaction Holes	Maximum wear is .031 in. (.80 mm).	Wear will be in the form of elongation of the holes. Original hole diameters are shown on the table below.
#30 Reaction Plate	Friction Wear Surfaces	Maximum wear (each Side) is .031 in. (.80 mm).	Wear will be in form of circular grooves on iron surface.
	Reaction Holes	Maximum wear is .031 in. (.80 mm).	Wear will be in the form of elongation of the holes. Original hole diameters are shown on the table below.
#12 Clamp Tube	Reaction Area	Maximum wear is .015 in. (.38 mm).	Wear will be in the form of a notch or step on the side of the tube.
#19 Cylinder	Seal Area	Maximum wear is .005 in. (.13 mm).	Wear will be in the form of grooves where the seals contact.
#22 Spring	Spring Free Height	Minimum free height shown on the table below.	Original free height shown on the table below. Springs must be replaced in complete sets.
#28 & #37 Gear and Ring Gear	Gear Backlash	Maximum allowable total backlash is .040 in. (1.0 mm).	Replace ring gear and gear together. If step is worn in gear, gear must be replaced.

<b>Original Reaction Hole Diameters in Pressure Plate and Reaction Plate</b>	
<b>Size</b>	<b>Diameter in. (mm)</b>
9DBB	.938 (23.83)
15DBB	1.312 (33.33)
20DBB	1.343 (34.11)
25DBB	1.688 (42.87)
38DBB	2.063(54.40)

<b>Original Spring Free Height</b>	
<b>Size</b>	<b>Free Height in. (mm)</b>
9DBB	2.50 (63.5)
15DBB	3.00 (76.2)
20DBB	4.44/4.56 (112.77/115.82)
25DBB	5.18 (131.57)
38DBB	6.80(172.7)

<b>Minimum Spring Free Height</b>	
<b>Size</b>	<b>Free Height in. (mm)</b>
9DBB	2.40 (61.0)
15DBB	2.84 (72.0)
20DBB	4.25 (107.95)
25DBB	4.9 (124.46)
38DBB	6.53(165.9)



**Warning:**

**If a wear adjustment is not made, the brake torque may deteriorate to the point where the equipment will not stop properly.**

- 4.2.1.1 Disconnect the air supply lines from the brake.
- 4.2.1.2 While supporting the cylinder, loosen the locknuts (18) ONE TURN AT A TIME and in an alternating (crosswise) pattern until the spring force is relieved.



**Caution:**

**The locknuts (18) must be loosened gradually to prevent damage to the brake components.**

- 4.2.1.3 Remove the locknuts and washers (17) and slide the cylinder, spring housing and pressure plate (14) off of the studs as an assembly. Set aside in a clean area making sure not to damage the friction material wear surface on the pressure plate.

Note: If a stud (6) should happen to come loose, remove it completely, clean the threads on the stud and the threads in the mounting flange. Apply Loctite Primer Grade "T" to the stud threads. After the threads have dried, assemble to the mounting flange using Loctite #262. The end of the stud must not extend past the mounting surface on the mounting flange.



**Caution:**

**Loctite® #262 must be shaken prior to application.**



**Caution:**

**Loctite® #262 may irritate sensitive skin. Refer to product label for safety precautions.**

- 4.2.1.4 Remove the outboard friction disc assembly, the reaction plate (31) and the separator springs (34) and set aside.

- 4.2.1.5 Slide the clamp tubes (12) and wear spacers (29) off of the studs. Reinstall the clamp tubes only.
- 4.2.1.6 Place a separator spring over every other clamp tube and slide the reaction plate onto the clamp tubes.
- 4.2.1.7 Slide the friction disc assembly onto the gear, noting the orientation of the heads of the screws attaching the friction disc to the ring gear (37). On dual disc brakes, the screw head on the friction discs will face each other.
- 4.2.1.8 Place a separator spring onto every other clamp tube and slide the pressure plate/cylinder assembly onto the clamp tubes.
- 4.2.1.9 Lubricate the threads on the ends of the studs with 30 wt. oil or anti-seizing compound and install the locknuts (18), washers (17) and the wear spacers removed in 4.2.1.5. The wear spacers are "stored" under the locknuts for use after replacing friction discs. See Figure 7.

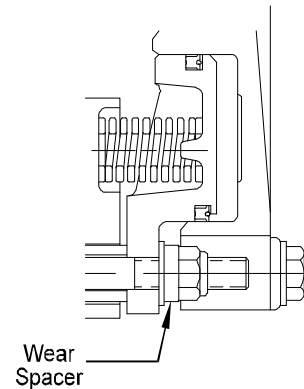

Fig. 7

- 4.2.1.10 While supporting the weight of the cylinder/spring housing/pressure plate assembly, tighten the locknuts, ONE TURN AT A TIME and in a cross-wise pattern, until the spring housing is seated against the clamp tubes. Torque the locknuts to the appropriate value. See Table 4.



**Caution:**

**The locknuts (18) must be tightened gradually to prevent damage to the brake components.**

### 4.3 Friction Material Replacement

- 4.3.1 Disconnect the air supply lines and remove the cylinder/spring housing/pressure plate assembly per 4.2.1.2.
- 4.3.2 Slide the friction disc assembly off of gear and transport to a clean area. On dual disc brakes, the reaction plate, separator springs and remaining friction disc assembly must also be removed.
- 4.3.3 Remove the screws (36) and washers (35) attaching the friction disc subassembly (7) to the ring gear (37) and remove the friction disc subassembly.
- 4.3.4 Thoroughly clean the threaded holes in the ring gear and the threads on the screws (36).
- 4.3.5 Attach a new friction disc subassembly to the ring gear using Loctite #262 on the screw threads. Torque the screws to the value shown on Table 4.

**! Warning:**

**Use only the proper size and grade screws to attach the friction disc subassembly to the ring gear. Use of commercial (Grade 2) screws where Grade 8 screws are specified may result in failure of the screws and a sudden loss of brake torque.**

- 4.3.6 Friction disc cores (9) may be relined with new friction material per the following instructions. Refer to Table 9 for the appropriate friction disc replacement kit part number.

**! Caution:**

**Use on genuine, Airflex friction material. Use of material not of Airflex origin may result in unpredictable brake performance and/or excessive wear of the brake components.**

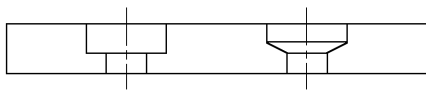

Fig. 8

TABLE 9 Friction Disc Repair Kits		
Brake Size	Kit Part Number	Rivet Setting Tool
9DBB	107742D	000153x1095
15DBB	107743D	000153x1096
200DBB	107744D	000153x1096
25DBB	107745D	000153x1096
38DBB	107746D	000153x1096
Single disc brakes require one kit.		
Dual disc brakes require two kits.		

- 4.3.6.1 Drill out the old rivets using the appropriate size drill as shown below. Remove and discard the old friction discs.
- 4.3.6.2 Refer to Figure 8 and carefully examine the counterbored holes in the new friction disc. One set of counterbored holes is tapered and designed to accept the rivet head, while the other set of counterbored holes is flat-bottomed and designed to accept the clinched end of the rivet.

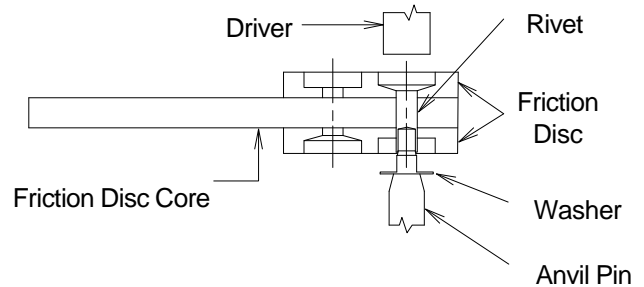

Fig. 9

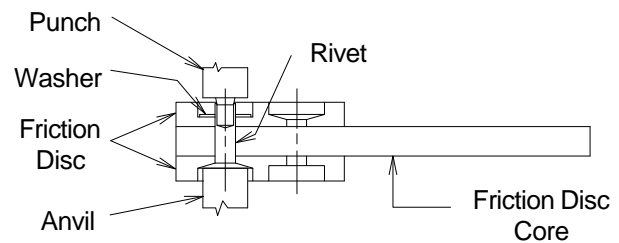

Fig. 10

- 4.6.6.3 Position the friction discs on both sides of the disc core and align the rivet holes. Remember, a tapered counterbored hole on one friction disc will mate with a flat-bottomed counterbored hole on the opposite friction disc.

**! Caution:**

Manual setting of the rivets using a punch very frequently results in splitting of the clinched end of the rivet. When this occurs, the rivet will ultimately fail in service due to fatigue. It is therefore recommended that rivets be set using automatic rivet setting machine.

- 4.3.6.4 Insert a rivet through any hole and set using a washer (11) on the clinched end of the rivet. Be sure to note the type of counterbored hole to determine the position of the rivet head. See Figures 9 and 10. Figure 9 shows machine-setting and Figure 10 shows setting the rivet manually. When setting manually, use an arbor press and keep the setting tool square to avoid splitting the rivet. Rivet setting tool part numbers are shown on Table 9.

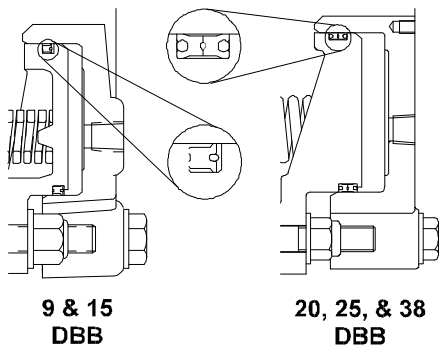

Fig. 11

**! Caution:**

The clinched end of the rivet must have a washer (11) in place prior to clinching. Failure to use the washer will allow the rivet to fracture the friction lining. Also, use of excessive force to clinch the rivet will fracture the friction lining.

- 4.3.6.5 The remaining rivets may be installed in any reasonable sequence following 4.3.6.4.

## 4.4 Cylinder Seal Replacement

- 4.4.1 Disconnect the air supply lines and remove the screws (20), washers (17) and spacer tubes (27) attaching the cylinder (19) to the pressure plate (14).

- 4.4.2 Carefully slide the cylinder off of the spring housing (16).

**! Caution:**

Do not use compressed air to remove the cylinder from the spring housing.

- 4.4.3 Remove the cylinder seals (21,23) from the spring housing and thoroughly clean the seal grooves in the spring housing.
- 4.4.4 Insert new seals into the grooves, noting the orientation of the seals per Figure 11.
- 4.4.5 Carefully examine the seal surfaces in the cylinder. If the surfaces have worn to point as indicated on Table 8, the cylinder must be replaced.
- 4.4.6 Lubricate the seal surfaces in the cylinder with Parker O-Lube and carefully slide the cylinder onto the spring housing. Take special care to avoid damaging the seal lips.
- 4.4.7 Attach the cylinder to the pressure plate with the screws, washers and spacer tubes removed in 4.4.1. Use Loctite Loc-Quic Primer Grade "T" to clean and prepare the screw threads and install with Loctite #262. Using a crosswise pattern, torque the screws to the value shown on Table 4.

## 4.5 Spring Replacement

### 4.5.1 (DBB 9 & 15)

- 4.5.1.1 Disconnect the air supply lines and loosen the locknuts (18), ONE TURN AT A TIME and in a crosswise pattern, until the spring force has been relieved.

**! Caution:**

The locknuts (18) must be loosened gradually to prevent damage to the brake components.

- 4.5.1.2 Remove the locknuts (18) and washers (17) and carefully remove the cylinder/spring housing/pressure plate assembly. Transport to a clean work area.
- 4.5.1.3 Loosen the screws (20) gradually until the remaining spring force is relieved. Remove the screws and washers (17).

4.5.1.4 Carefully lift the cylinder and spring housing off of the pressure plate, exposing the springs (22).



**Before removing the old springs, make note of the number used and the position that they are in so that the new springs may be installed similarly for proper brake functioning.**

4.5.1.5 Remove the springs and check the free height. If the free height of any spring is less than the value shown on Table 8, the entire complement of springs must be replaced.

4.5.1.6 Re-install the springs into the pockets in the pressure plate in reverse order.

4.5.1.7 Place a spacer tube (27) in position over each tapped hole in the pressure plate and carefully lower the spring housing/cylinder assembly onto the springs, making sure the springs engage the bosses in the spring housing.

4.5.1.8 Clean and prepare the threads on the screws (20) with Loctite Loc-Quic Primer Grade "T" and install with Loctite #262, making sure the washers (17) are in place. Using a crosswise pattern, tighten the screws one turn at a time until the spacer tubes are clamped between the cylinder and pressure plate. Torque the screws to the value shown on Table 4.

4.5.1.9 While supporting the weight of the cylinder/spring housing/pressure plate assembly, tighten the locknuts, ONE TURN AT A TIME and in a crosswise pattern, until the spring housing is seated against the clamp tubes. Torque the locknuts to the appropriate value. See Table 4.



**The locknuts (18) must be tightened gradually to prevent damage to the brake components.**

#### 4.5.2 (DBB 20, 25 & 38)

4.5.2.1 Disconnect the air supply lines and loosen the locknuts (18), ONE TURN AT A TIME and in a crosswise pattern, until the spring force has been relieved.

4.5.2.2 Match mark the pressure plate and spring housing to one another.



**The locknuts (18) must be loosened gradually to prevent damage to the brake components.**

4.5.2.3 Remove the locknuts (18) and washers (17) and carefully remove the cylinder/spring housing/pressure plate assembly. Transport to a clean work area.

4.5.2.4 Loosen the screws (20) gradually until the remaining spring force is relieved. Remove the screws and washers (17).

4.5.2.5 Carefully lift the cylinder and spring housing off of the pressure plate, exposing the springs (22).



**Before removing the old springs, make note of the number used and the position that they are in so that the new springs may be installed similarly for proper brake functioning.**

4.5.2.6 Noting their orientation, remove the spring retainer plates (53), exposing the springs.

4.5.2.7 Remove the springs and check the free height. If the free height of any spring is less than the value shown on Table 8, the entire complement of springs must be replaced.

4.5.2.8 Re-install the springs into the pockets in the pressure plate in reverse order.



**No spring retainer plate (53) should cross over the ribs in the spring housing (16).**

4.5.2.9 Arrange the spring retainer plates onto the springs in the reverse order removed.

- 4.5.2.10 Place a spacer tube (27) in position over each tapped hole in the pressure plate, align the match marks and carefully lower the spring housing/cylinder assembly onto the springs, making sure the springs engage the bosses in the spring housing.
- 4.5.2.11 Clean and prepare the threads on the screws (20) with Loctite Loc-Quic Primer Grade "T" and install with Loctite #262, making sure the washers (17) are in place. Using a crosswise pattern, tighten the screws, one turn at a time until the spacer tubes are clamped between the cylinder and pressure plate. Torque the screws to the value shown on Table 4.
- 4.5.2.12 While supporting the weight of the cylinder/spring housing/pressure plate assembly, tighten the locknuts, ONE TURN AT A TIME, and in a crosswise pattern, until the spring housing is seated against the clamp tubes. Torque the locknuts to the appropriate value. See Table 4.



**Caution:**

**The locknuts (18) must be tightened gradually to prevent damage to the brake components.**

## **5.0 ORDERING INFORMATION/ TECHNICAL ASSISTANCE**

### **5.1 Equipment Reference**

- 5.1.1 In any correspondence regarding Airflex Equipment, refer to the information on the product nameplate and call or write.

Eaton Corporation  
Airflex Division  
9919 Clinton Road  
Cleveland, Ohio 44144  
Tel.: (216) 281-2211  
Toll Free: (800) AIRFLEX or (800) 824-1586  
Fax: (216) 281-3890

Loctite and loc-Quic are registered trademarks of Loctite Corporation.  
Molub-Alloy OG Heavy is a registered trademark of Imperial Oil and Grease Co.

## 6.0 PARTS LISTS

ITEM	DESCRIPTION	109 DBB (146333E)		209 DBB (146334E)		309DBB (146380E)	
		Part Number	Qty	Part Number	Qty	Part Number	Qty
2	Mounting Flange	512554	1	512554	1	512554	1
6	Stud	000245X0046	6	000245X0055	6	000245X0102	6
7	Friction Disc Assembly (1)	512567	1	512567	2	512567	3
8	Friction Disc (2)	512565	2	512565	2	512565	2
9	Friction Disc Core (2)	512566	1	512566	1	512566	1
10	Rivet (2)	000130X0093	20	000130X0093	20	000130X0093	20
11	Washer (2)	000067X0036	20	000067X0036	20	000067X0036	20
12	Clamp Tube	307694-03	6	307694-04	6	307694-06	6
14	Pressure Plate	512537	1	512537	1	512537	1
16	Spring Housing	512491	1	512491	1	512491	1
17	Flat Washer	000067X0041	12	000067X0041	12	000067X0041	12
18	Locknut	000110X0024	6	000110X0024	6	000110X0024	6
19	Cylinder	512483	1	512483	1	512483	1
20	Hex Head Screw	000197X0418	6	000197X0418	6	000197X0418	6
21	Inner PolyPac Seal	000402X0001	1	000402X0001	1	000402X0001	1
22	Spring (Outer)	308225	12	308225	12	308225	12
23	Outer PolyPac Seal	000402X0002	1	000402X0002	1	000402X0002	1
27	Spacer Tube	307710-01	6	307710-01	6	307710-01	6
28	Gear (3)	41513-####	1	415314-####	1	416481-####	1
29	Wear Spacer	-	-	307710-02	6	307710-02	12
31	Reaction Plate	-	-	512541	1	512541	2
34	Release Spring	-	-	307709	12	307709	18
35	Flat Washer	000067X0001	12	000067X0001	24	000067X0001	24
36	Hex Head Screw	000197X0005	12	000197X0005	24	000197X0005	24
37	Ring Gear	415309	1	415309	2	415309	3
38	Pipe Nipple	000070X0064	1	000070X0064	1	000070X0064	1
39	Elbow	000078X0002	4	000078X0002	4	000078X0002	4
40	Pipe Nipple	000070X0021	2	000070X0021	2	000070X0021	2
41	Reducing Tee	000161X0010	1	000161X0010	1	000161X0010	1
42	Hose Assembly	000318X0030	2	000318X0030	2	000318X0030	2
43	Pipe Nipple	000070X0020	2	000070X0020	2	000070X0020	2
44	Flow Control Valve	000042X0223	1	000042X0223	1	000042X0223	1
45	45° Street Elbow	-	-	-	-	-	-
46	Pipe Cross	-	-	-	-	-	-
47	Pipe Reducer	-	-	-	-	-	-
48	Hose Assembly	-	-	-	-	-	-
52	Spring (Inner)	-	-	-	-	-	-
53	Spring Retainer	-	-	-	-	-	-
56	Hex Head Cap Screw	-	-	-	-	-	-

(1) Sub-assembly of items 8, 9, 10, & 11.

(2) Quantity listed is number required for one friction disc sub-assembly (7)

(3) Not included with element.

ITEM	DESCRIPTION	115 DBB (146222E)		215 DBB (146337E)		315DBB (146929E)	
		Part Number	Qty	Part Number	Qty	Part Number	Qty
2	Mounting Flange	512462	1	512462	1	512462	1
6	Stud	000245X0059	6	000245X0061	6	000245X0064	6
7	Friction Disc Assembly (1)	512293	1	512293	1	512293	3
8	Friction Disc (2)	512305	2	512305	2	512305	2
9	Friction Disc Core (2)	512303	1	512303	1	512303	1
10	Rivet (2)	000130X0094	28	000130X0094	28	000130X0094	28
11	Washer (2)	000067X0043	28	000067X0043	28	000067X0043	28
12	Clamp Tube	306956-05	6	306956-06	6	306956-31	6
14	Pressure Plate	512449	1	512449	1	512440	1
16	Spring Housing	512295	1	512295	1	512295	1
17	Flat Washer	000067X0040	12	000067X0040	12	000067X0040	12
18	Locknut	000110X0030	6	000110X0030	6	000110X0030	6
19	Cylinder	512296	1	512296	1	512296	1
20	Hex Head Screw	000197X0719	6	000197X0719	6	000197X0719	6
21	Inner PolyPac Seal	000402X0003	1	000402X0003	1	000402X0003	1
22	Spring (Outer)	308224	12	308224	12	308224	12
23	Outer PolyPac Seal	000402X0004	1	000402X0004	1	000402X0004	1
27	Spacer Tube	307636-01	6	307636-01	6	307636-01	6
28	Gear (3)	415454-####	1	415302-####	1	416483-####	1
29	Wear Spacer	-	-	308155-01	6	308155-01	12
31	Reaction Plate	-	-	512340	1	512340	2
34	Release Spring	-	-	307641	6	307641	9
35	Flat Washer	000067X0003	12	000067X0003	24	000067X0003	24
36	Hex Head Screw	000197X0207	12	000197X0207	24	000197X0207	24
37	Ring Gear	415118	1	415118	2	415118	3
38	Pipe Nipple	000070X0147	1	000070X0147	1	000070X 0147	1
39	Elbow	000078X0001	2	000078X0001	2	000078X0001	2
40	Pipe Nipple	-	-	-	-	-	-
41	Reducing Tee	000161X0008	1	000161X0008	1	000161X0008	1
42	Hose Assembly	00318X0029	2	000318X0029	2	000318X0029	2
43	Pipe Nipple	000070X0166	2	000070X00166	2	000070X0166	2
44	Flow Control Valve	000042X0224	1	000042X0224	1	000042X0224	1
45	45° Street Elbow	000081X0001	2	000081X0001	2	000081X0001	2
46	Pipe Cross	-	-	-	-	-	-
47	Pipe Reducer	-	-	-	-	-	-
48	Hose Assembly	000318X0004	1	000318X0004	1	000318 X 0004	1
52	Spring (Inner)	-	-	-	-	-	-
53	Spring Retainer	-	-	-	-	-	-
56	Hex Head Cap Screw	000197X0611	2	-	-	-	-

- (1) Sub-assembly of items 8, 9, 10, & 11.  
(2) Quantity listed is number required for one friction disc sub-assembly (7)  
(3) Not included with element.

ITEM	DESCRIPTION	120 DBB (146299E)		220 DBB (146300E)		320DBB (146378E)		420DBB (146379E)	
		Part Number	Qty	Part Number	Qty	Part Number	Qty	Part Number	Qty
2	Mounting Flange	512752	1	512752	1	512752	1	512752	1
6	Stud	000245X0061	12	000245X0064	12	000245X0063	12	000245X0103	12
7	Friction Disc Assembly (1)	512768	1	512768	2	512768	3	512768	4
8	Friction Disc (2)	512766	2	512766	2	512766	2	512766	2
9	Friction Disc Core (2)	512767	1	512767	1	512767	1	512767	1
10	Rivet (2)	000130X0094	40	000130X0094	40	000130X0094	40	000130X0094	40
11	Washer (2)	000060X0039	40	000060X0039	40	000060X0039	40	000060X0039	40
12	Clamp Tube	306956-09	12	306956-10	12	306956-19	12	306956-30	12
14	Pressure Plate	512637	1	512637	1	512637	1	512637	1
16	Spring Housing	512639	1	512639	1	512639	1	512639	1
17	Flat Washer	000153X0727	24	000153X0727	24	000153X0727	24	000153X0727	24
18	Locknut	000110X0030	12	000110X0030	12	000110X0030	12	000110X0030	12
19	Cylinder	512693	1	512693	1	512693	1	512693	1
20	Hex Head Screw	000197X0723	12	000197X0723	12	000197X0723	12	000197X0723	12
21	Inner PolyPac Seal	000402X0021	2	000402X0021	2	000402X0021	2	000402X0021	2
22	Spring (Outer)	307947	12	307947	12	307947	12	307947	12
23	Outer PolyPac Seal	000402X0022	2	000402X0022	2	000402X0022	2	000402X0022	2
27	Spacer Tube	308155-06	12	308155-06	12	308155-06	12	308155-06	12
28	Gear (3)	415900-####	1	416059-####	1	416304-####	1	416471-####	1
29	Wear Spacer	-	-	308155-02	12	308155-02	24	308155-02	36
31	Reaction Plate	-	-	512763	1	512763	2	512763	3
34	Release Spring	-	-	307996	12	307996	18	307996	24
35	Flat Washer	000067X0003	16	000067X0003	32	000067X0003	32	000067X0003	32
36	Hex Head Screw	000197X0207	16	000197X0207	32	000197X0207	32	000197X0207	32
37	Ring Gear	513193	1	513193	2	513193	3	513193	4
38	Pipe Nipple	000070X0147	1	000070X0147	1	000070X0147	1	000070X0147	1
39	Elbow	000078X0001	3	000078X0001	3	000078X0001	3	000078X0001	3
40	Pipe Nipple	-	-	-	-	-	-	-	-
41	Reducing Tee	-	-	-	-	-	-	-	-
42	Hose Assembly	000318X0032	2	000318X0032	2	000318X0032	2	000318X0032	2
43	Pipe Nipple	000070X0206	4	000070X0247	4	000070X0247	4	000070X0247	4
44	Flow Control Valve	000042X0224	1	000042X0224	1	000042X0224	1	000042X0224	1
45	45° Street Elbow	000081X0001	2	000081X0001	2	000081X0001	2	000081X0001	2
46	Pipe Cross	000185X0001	1	000185X0001	1	000185X0001	1	000185X0001	1
47	Pipe Reducer	000085X0004	3	000085X0004	3	000085X0004	3	000085X0004	3
48	Hose Assembly	000318X0004	1	000318X0004	1	000318X0004	1	000318X0004	1
52	Spring (Inner)	-	-	-	-	-	-	-	-
53	Spring Retainer	415823	6	415823	6	415823	6	415823	6
56	Hex Head Cap Screw	-	-	-	-	-	-	-	-

(1) Sub-assembly of items 8, 9, 10, & 11.

(2) Quantity listed is number required for one friction disc sub-assembly (7)

(3) Not included with element.

ITEM	DESCRIPTION	125 DBB (146315E)		225 DBB (146327E)		325DBB (146370E)		425DBB (146381E)	
		Part Number	Qty	Part Number	Qty	Part Number	Qty	Part Number	Qty
2	Mounting Flange	513276	1	513276	1	514199	1	514199	1
6	Stud	000245X0067	12	000245X0078	12	000245X0100	12	000245X0101	12
7	Friction Disc Assembly (1)	513293	1	513293	2	513293	3	513293	4
8	Friction Dis (2)	513291	2	513291	2	513291	2	513291	2
9	Friction Disc Core (2)	513292	1	513292	1	513292	1	513292	1
10	Rivet (2)	000130X0094	64	000130X0094	64	000130X0094	64	000130X0094	64
11	Washes (2)	000067X0039	64	000067X0039	64	000067X0039	64	000067X0039	64
12	Clamp Tube	306542-15	12	306542-16	12	306542-27	12	306542-35	12
14	Pressure Plate	513271	1	513271	1	513271	1	513271	1
16	Spring Housing	513268	1	513268	1	513268	1	513268	1
17	Flat Washer	000153X0641	24	000153X0641	24	000153X0641	24	000153X0641	24
18	Locknut	000110X0073	12	000110X0073	12	000110X0073	12	000110X0073	12
19	Cylinder	513264	1	513264	1	513264	1	513264	1
20	Hex Head Screw	000197X1035	12	000197X1035	12	000197X1035	12	000197X1035	12
21	Inner PolyPac Seal	000402X0023	2	000402X0023	2	000402X0023	2	000402X0023	2
22	Spring (Outer)	307970	16	307970	16	307970	16	307970	16
23	Outer PolyPac Seal	000402X0024	2	000402X0024	2	000402X0024	2	000402X0024	2
27	Spacer Tube	308170-02	12	308170-02	12	308170-02	12	308170-02	12
28	Gear (3)	416073-####	1	416074-####	1	416233-####	1	416477-####	1
29	Wear Spacer	-	-	308170-01	12	308170-01	24	308170-01	36
31	Reaction Plate	-	-	513319	1	513319	2	513319	3
34	Release Spring	-	-	308037	12	308037	18	308037	24
35	Flat Washer	000067X0005	18	000067X0005	36	000067X0005	54	000067X0005	72
36	Hex Head Screw	000197X0409	18	000197X0409	36	000197X0408	54	000197X0408	72
37	Ring Gear	513278	1	513278	2	513797	3	513797	4
38	Pipe Nipple	000070X0147	1	000070X0147	1	000070X0147	1	000070X0147	1
39	Elbow	000078X0001	3	000078X0001	3	000078X0001	3	000078X0001	3
40	Pipe Nipple	-	-	-	-	000070X0166	1	000070X0166	1
41	Reducing Tee	-	-	-	-	-	-	-	-
42	Hose Assembly	000318X0038	2	000318X0038	2	000318X0018	2	000318X0038	2
43	Pipe Nipple	000070X0247	4	000070X0247	4	000070X0247	3	000070X0247	3
44	Flow Control Valve	000042X0224	1	000042X0224	1	000042X0224	1	000042X0224	1
45	45° Street Elbow	000081X0001	2	000081X0001	2	000081X0001	2	000081X0001	2
46	Pipe Cross	000185X0001	1	000185X0001	1	000185X0001	1	000185X0001	1
47	Pipe Reducer	000085X0004	3	000085X0004	3	000085X0004	3	000085X0004	3
48	Hose Assembly	000318X0004	1	000318X0004	1	000318X0004	1	000318X0004	1
52	Spring (Inner)	307969	16	307969	16	307969	16	307969	16
53	Spring Retainer	307971	8	307971	8	307971	8	307971	8
56	Hex Head Cap Screw	-	-	-	-	-	-	-	-

(1) Sub-assembly of items 8, 9, 10, & 11.

(2) Quantity listed is number required for one friction disc sub-assembly (7)

(3) Not included with element.

ITEM	DESCRIPTION	138 DBB (146295E)		238 DBB (146296E)		338DBB (146386E)		438DBB (146387E)	
		Part Number	Qty	Part Number	Qty	Part Number	Qty	Part Number	Qty
2	Mounting Flange	513137	1	513137	1	513137	1	513137	1
6	Stud	000245X0072	16	000245X0074	16	000245X0107	12	000245X0104	12
7	Friction Disc Assembly(Bonded)	514024	1	514024	2	514024	3	514024	4
8	Friction Disc	-	-	-	-	-	-	-	-
9	Friction Disc Core	-	-	-	-	-	-	-	-
10	Rivet	-	-	-	-	-	-	-	-
11	Washer	-	-	-	-	-	-	-	-
12	Clamp Tube	307941-01	16	307941-02	16	307941-12	12	307941-13	12
14	Pressure Plate	513071	1	513071	1	513071	1	513071	1
16	Spring Housing	513764	1	513764	1	513764	1	513764	1
17	Flat Washer	000067X0042	32	000067X0042	32	000067X0042	24	000067X0042	24
18	Locknut	000110X0075	16	000110X0075	16	000110X0075	12	000110X0075	12
19	Cylinder	513988	1	513988	1	513988	1	513988	1
20	Hex Head Screw	000197X1338	16	000197X1338	16	000197X1338	12	000197X1338	12
21	Inner PolyPac Seal	000402X0005	2	000402X0005	2	000402X0005	2	000402X0005	2
22	Spring (Outer)	30835	32	30835	32	308035	16	308035	16
23	Outer PolyPac Seal	000402X0006	2	000402X0006	2	000402X0006	2	000402X0006	2
27	Spacer Tube	308150-01	16	308150-01	16	308150-01	12	308150-01	12
28	Gear (3)	416068-####	1	416069-####	1	416241-####	1	416469-####	1
29	Wear Spacer	-	-	308150-02	16	308150-05	24	308150-05	36
31	Reaction Plate	-	-	513139	1	513139	2	513139	3
34	Release Spring	-	-	307940	16	307940	18	307940	24
35	Flat Washer	000067X00019	24	000067X0009	48	000067X0009	54	000067X0009	72
36	Hex Head Screw	000197X0709	24	000197X0709	48	000197X0709	54	000197X0709	72
37	Ring Gear	513154	1	513154	2	513811	3	513811	4
38	Pipe Nipple	000070X0244	1	000070X0244	1	000070X0244	1	000070X0244	1
39	Elbow	000078X0009	3	000078X0009	3	000078X0009	3	000078X0009	3
40	Pipe Nipple	-	-	-	-	-	-	-	-
41	Reducing Tee	-	-	-	-	-	-	-	-
42	Hose Assembly	000318X0033	2	000318X0033	2	000318X0033	2	000318X0033	2
43	Pipe Nipple	000070X0138	4	000070X0138	4	000070X0138	3	000070X0138	3
44	Flow Control Valve	000042X0215	1	000042X0215	1	000042X0215	1	000042X0215	1
45	45° Street Elbow	000081X0005	2	000081X0005	2	000081X0005	2	000081X0005	2
46	Pipe Cross	000185X0004	1	000185X0004	1	000185X0004	1	000185X0004	1
47	Pipe Reducer	000085X0005	3	000085X0005	3	000085X0005	3	000085X0005	3
48	Hose Assembly	000318X0023	1	000318X0023	1	000318X0023	1	000318X0023	1
52	Spring (Inner)	308034	32	308034	32	308034	16	308034	16
53	Spring Retainer	415635	16	415635	16	415635	8	415635	8
56	Hex Head Cap Screw	-	-	-	-	-	-	-	-

(1) Sub-assembly of items 8, 9, 10, & 11.

(2) Quantity listed is number required for one friction disc sub-assembly (7)

(3) Not included with element.

## **EATON PRODUCT WARRANTY**

Subject to the conditions stated herein, Eaton Corporation warrants to the Purchaser that each new Airflex Product manufactured by Eaton will be free from failures caused by defects in material and workmanship, and will deliver its rated capacity, for a period of twelve (12) months from the date of shipment to Purchaser, provided such Product is properly installed, properly maintained, operated under normal conditions and with competent supervision. Warranty claims shall be made in writing and the part or parts shall, if requested by Airflex Division, be returned prepaid to the Airflex Division for inspection. Upon a determination that a defect exists, Eaton shall thereupon correct any defect, at its option either by repairing any defective part or parts or by making available at Eaton's plant a repaired or replacement part. This warranty does not extend to normal wear parts or components of the Product, such as friction material and friction surfaces.

## **LIMITATION OF WARRANTY**

THE FOREGOING WARRANTY IS EXCLUSIVE AND IN LIEU OF ALL OTHER WARRANTIES WHETHER WRITTEN, ORAL OR IMPLIED. ANY IMPLIED WARRANTY OF MERCHANTABILITY OR FITNESS FOR A PARTICULAR PURPOSE ARE SPECIFICALLY EXCLUDED.

In no event shall Eaton be liable for special, incidental or consequential damages. Eaton's liability arising out of the supplying of such Product, or its use, whether in warranty, contract or otherwise shall in no case exceed the cost of correcting defects in the Products as herein provided. Upon expiration of the twelve (12) month period, all such liability shall terminate. THE FOREGOING SHALL CONSTITUTE THE SOLE REMEDY OF PURCHASER AND THE SOLE LIABILITY OF EATON.