

DBA 8082



Warning

Forward this **manual** to the person responsible for Installation, Operation and Maintenance of the product described herein. Without access to this information, faulty Installation, Operation or Maintenance may result in personal injury or equipment damage.

Installation, Operation and Maintenance of Airflex[®] 229 DBA Brake Assemblies with the Model “494” Disc Centering Option

For Horizontal 822 and 824 Frame Drag and Hoist Motors

- Ref.: Airflex[®] assemblies 146163EP (drawing 513707)
and 146163ER (drawing 513769)



Caution:

Use Only Genuine Airflex[®] Replacement Parts

The Airflex Division of Eaton Corporation recommends the use of genuine Airflex replacement parts. The use of non-genuine Airflex replacement parts could result in substandard product performance, and may void your Eaton warranty. For optimum performance, contact Airflex:

In the U.S.A. and Canada: (800) 233-5890
Outside the U.S.A. and Canada: (216) 281-2211



December, 1995

204106

© Copyright Eaton Corp., 1995. All rights reserved.

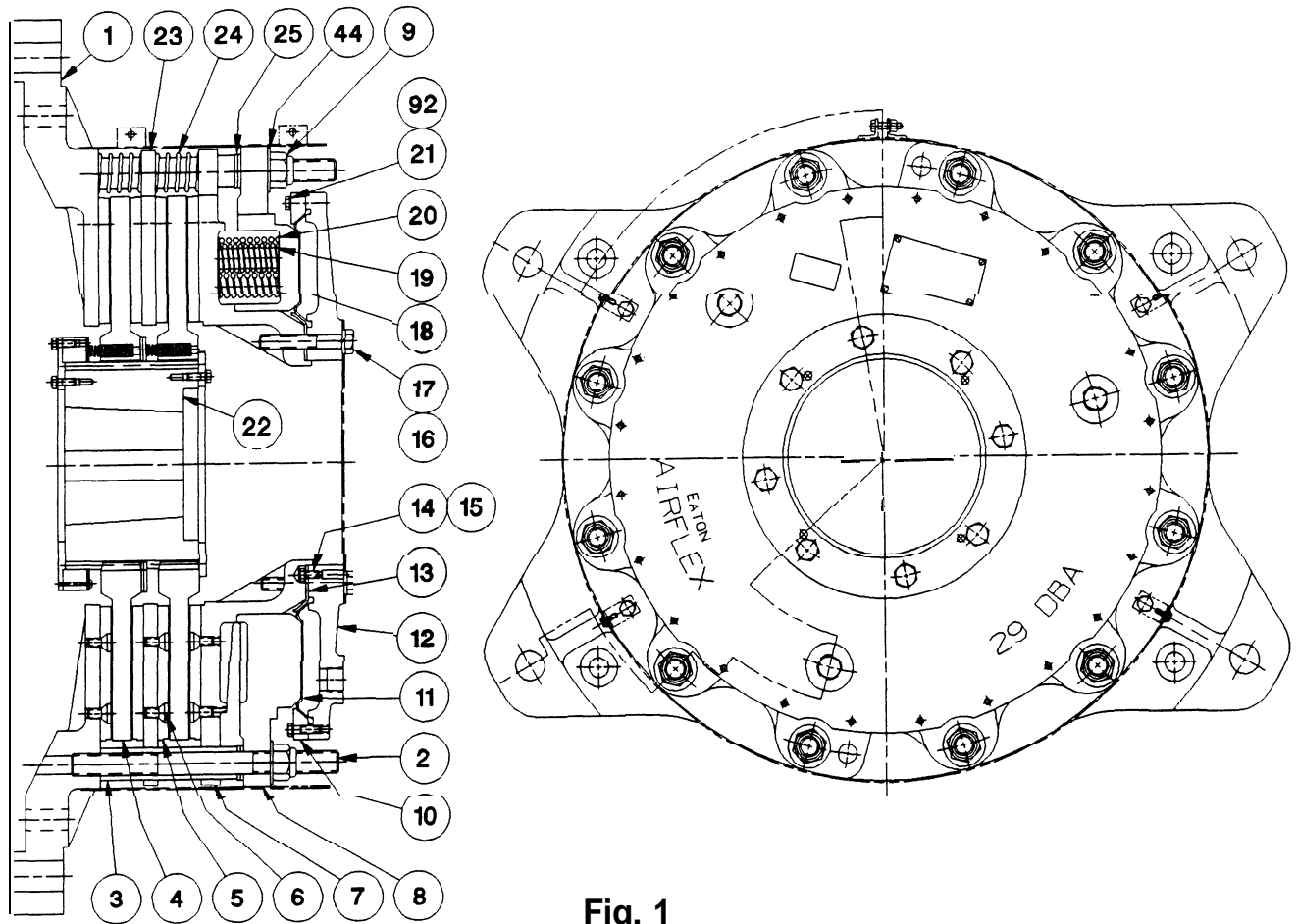

Fig. 1

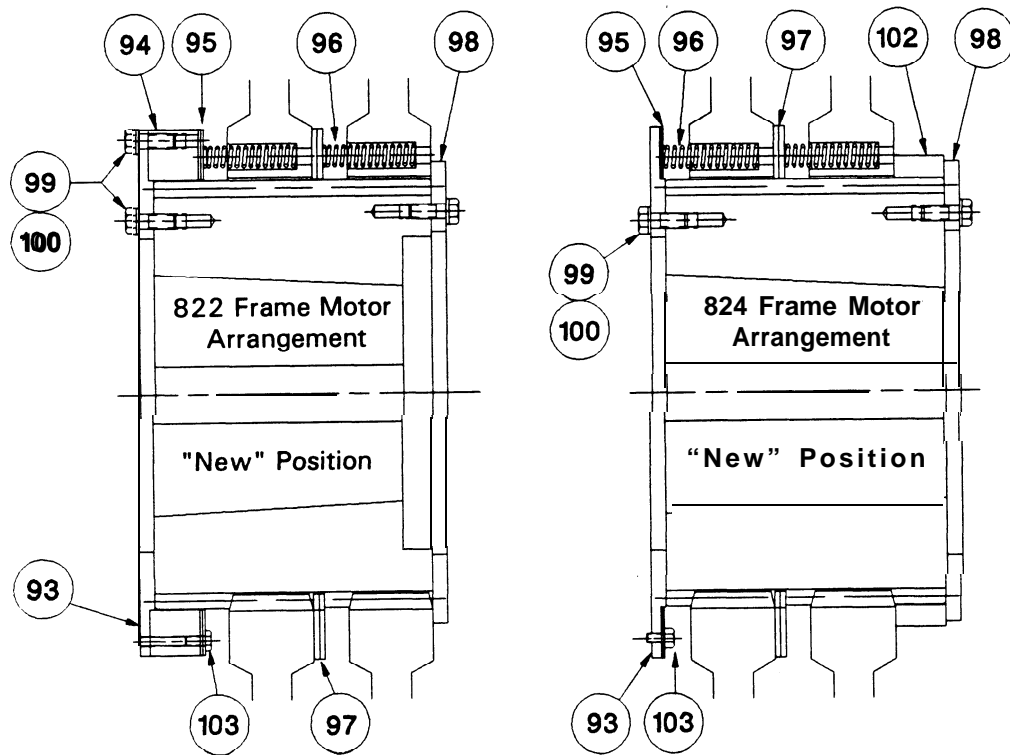



Fig. 2

Item	Description	Part Number & Quantity			
		146163EP (824 Motors)		146163ER (822 Motors)	
	229DBA Brake Assembly				
1	Mounting Flange	414246	1	414245	1
2	Stud	307261-05	12	307261-05	12
3	Clamp Tube	306542-21	12	306542-21	12
4	Disc	413579	2	413579	2
5	Friction Disc	414665	4	414665	4
6	Flat Head Screw	294 x 407	144	294 x 407	144
7	Pressure Plate	510619	1	510619	1
8	Spring Housing	510616	1	510616	1
9	Lock Nut	110 x 73	12	110 x 73	12
10	Outer Clamp Ring	414922	8	414922	8
11	Diaphragm	4075 17-02	1	4075 17-02	1
12	End Plate	413581	1	413581	1
13	inner Clamp Ring	407684-02	1	407684-02	1
14	Hex Head Screw	1 x 205	4	1 x 205	4
15	Lockwasher	68 x 7	4	68 x 7	4
16	Hex Head Screw	203806	8	203806	8
17	Lockwasher	68 x 25	8	68 x 25	8
18	Spring Retainer Plate	413583	24	413583	24
19	Inner Spring	307044	30	307044	30
20	Outer Spring	307045	30	307045	30
21	Hex Head Screw	1 X 209	24	1 x 209	24
22	Gear	413801-08	0	413801-18	①
23	Reaction Plate	413586	1	413586	1
24	Reaction Spring	306909	12	306909	12
25	Wear Spacer	307952	24	307952	24
44	Flat Washer	153 x 641	12	153 x 641	12
92	Flat Washer	67 x 3	24	67 x 3	24
93	Front Plate	416186	1	416186	1
94	Spacer Plate	-----	---	416192	1
95	Spacer Plate	415836	2	415836	2
96	Spring	71 x 118	8	71 x 118	8
97	Spacer Plate	415837	2	415837	2
98	End Plate	415171	1	415171	1
99	Hex Head Screw	197 x 207	8	197 x 207	11
100	Lockwasher	68 x 7	8	68 x 7	11
101	Shim ②	153 x 1020	36	153 x 1020	36
102	Spacer Plate	416189	1	-----	---
103	Hex Head Screw	385 x 3	2	385 x 3	2

① Not included with brake assembly. Order separately.

② Not shown. Note: Entire quantity shown may not be required for installation purposes.

1.0 INTRODUCTION

Throughout this manual there are a number of HAZARD WARNINGS that must be read and adhered to in order to prevent possible personal injury and/or damage to the equipment. Three signal words “DANGER”, “WARNING”, and “CAUTION” are used to indicate the severity of the hazard, and are preceded by the safety alert symbol .

DANGER



Denotes the most serious injury hazard, and is used when serious injury or death WILL result from misuse or failure to follow specific instructions.

WARNING

Used when serious injury or death MAY result from misuse or failure to follow specific instructions.

CAUTION

Used when injury or product/equipment damage may result from misuse or failure to follow specific instructions.

It is the responsibility and the duty of all personnel involved in the installation, operation and maintenance of the equipment on which this device is used to fully understand the  DANGER,  WARNING, and  CAUTION procedures by which hazards are to be avoided.

1.1 Description

- 1.1.1 The Airflex DBA brake is designed to provide braking in heavy-duty industrial applications. The brake is spring applied and air released, thus, stopping the machinery if a loss of air supply occurs.
- 1.1.2 The brakes described in this manual have been modified specifically for use on drag-line applications, for installation on horizontally mounted 822 and 824 frame motors.
- 1.1.3 Included with these brakes is the Airflex® Model 494 Disc Centering Device. The disc centering components have been designed specifically to work with Airflex 229DBA brakes. Disc centering helps to minimize wear of the friction surfaces caused by the

brake discs dragging against the friction material while the brake is in the fully released position. Although a certain amount of disc dragging is acceptable, high cable payout speeds can generate excessive heat at the disc surfaces and accelerate friction material wear.

- 1.1.4 The design of the Model 494 disc centering option allows for wear adjustment of the 229DBA brake by simply rearranging spacer components.
- 1.1.5 Use of these procedures to install 229DBA brakes which are not in as-new condition (full friction disc (5) and disc (4) thickness) may result in improper assembly or setup.

Warning:

Improper installation procedures will result in inferior performance and possible brake failure.

1.2 How it Works

- 1.2.1 Referring to Figure 1, the gear (22) is mounted to the shaft which is to be stopped and the brake assembly is attached to the motor frame.
- 1.2.2 Air pressure is applied through the ports in the end plate (12) into the diaphragm cavity. As the air pressure increases, the end plate and pressure plate (7), which are attached to each other with screws (16) and lockwashers (17), move away from the mounting flange (1). The pressure plate compresses the springs (19)(20) against the stationary spring housing (8) and the clamp force is removed from the discs (4) which ride on the gear. The discs are then free to rotate. As the pressure plate continues to move away from the mounting flange, the reaction plate (23) and discs are relocated by means of spacers and springs.
- 1.2.3 As air pressure is exhausted from the brake, the springs (19)(20) force the pressure plate toward the mounting flange. The spring forces within the brake overcome the spring forces positioning the discs and reaction plate, allowing the discs to slide axially towards the mounting flange and become clamped between the friction discs.

2.0 INSTALLATION



Danger:

Prior to installation or removal of the DBA Brake, make sure that the machinery will remain in a secured position. Failure to do so could result in serious personal injury or possibly death.

2.1 Preparation

- 2.1.1 Inspect the mounting lugs on the motor for broken welds or improper location. All mounting lugs should be flat and within a common perpendicular plane to the motor shaft. With the motor shaft centered between its axial limits, the axial dimension "A" between the motor side of the gear (22) and the mounting lugs should measure 3.09" for 822 frame motors, and 1.96" for 824 frame motors. See Figure 3. Shims can be added if necessary. Correct as required.

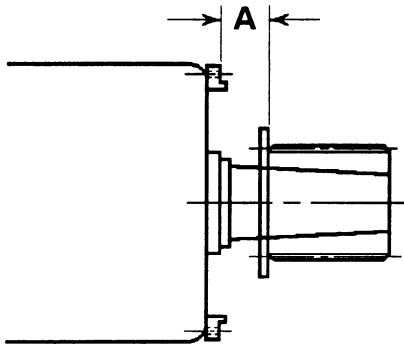

Fig. 3

- 2.1.2 For proper operation and service life, the DBA Brake must be mounted concentrically and at right angles to the shaft. Concentricity of shaft and brake should be held to within .010". Perpendicularity of the mounting flange (1) should be held within .014" TIR, referenced at the machined surface just outside of the friction disc (ref.: 29" diameter).



Caution:

Proper alignment is necessary to assure that the discs (4) will track properly. Improper alignment will result in excessive wear to the friction discs (5), discs (4) and gear (22). See Figure 4.

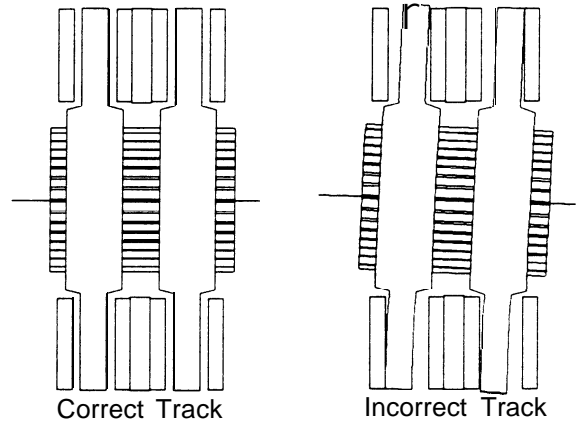

Fig. 4

2.2 Gear Mounting

It may be desirable to verify armature endplay prior to installing the gear onto the motor shaft, in the event that repairs may be required. Refer to 2.4.1 and 2.4.2.



Warning:

Armature endplay in excess of manufacturer's maximum specification of 11/64" may result in premature wear or damage to the brake components.

- 2.2.1 Ensure that the motor shaft is clean and free of nicks or burrs and that the key fits properly in the shaft and gear. Tap the key into the shaft keyway and position the gear (22) on the shaft to check for binding of the key. Correct if necessary.
- 2.2.2 Mount the gear cold by placing it on the shaft and snapping it in position by hand. Measure the cold position of the gear, using a micrometer depth gauge, as on Figure 5. Mark the position of the depth gauge, so that measurements can be taken from the same position after the gear has been mounted.

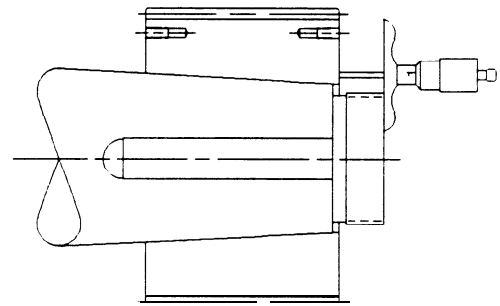

Fig. 5

2. 2. 3 Remove the gear from the shaft and heat it in an oven to a temperature approximately 110°F above that of the temperature of the shaft. For example if the shaft temperature is 70°F, heat the gear to a stable temperature of approximately 180°F for mounting.

Note: This temperature difference is estimated only and can be adjusted to maintain the advance specified in the following procedures,

2. 2. 4 After making sure the bore is clean, mount the heated gear on the shaft. When the gear is nearly engaged with the taper fit, snap it forcibly in place with a quick push.
2. 2. 5 After allowing the gear to cool, check the position of the gear on the shaft with the micrometer depth gauge. Subtract the reading obtained in 2.2.2 from this dimension. The difference between the two readings should be .040" + /- .010". If the advance is not within .030" to .050", the gear should be pulled and remounted.
2. 2. 6 Secure the gear to the shaft with the nut and lockwasher provided with the motor, tightening the nut firmly. Bend the lockwasher against one flat of the nut.

2.3 Disassembly of the DBA Brake

Partial disassembly is required to install DBA brakes utilizing the Model 494 disc centering option.

2. 3. 1 Lay the brake assembly on a clean, flat surface, with the mounting flange (1) facing down.
2. 3. 2 Loosen the locknuts (9) ONE TURN AT A TIME in an alternating (crosswise) pattern until the spring force is relieved.



Caution:

The locknuts must be loosened gradually to prevent damage to the brake components.

2. 3. 3 Remove the locknuts and washers (44) and slide the end plate (12), spring housing (8), and the pressure plate (7) off the studs as an assembly, setting it aside on a clean dry surface. Set aside the wear spacers (25) removed from the assembly.

Note: If a stud (2) should happen to come loose, remove it completely and clean the

threads in the mounting flange. Apply Loctite® Loc-Quic® Primer Grade "T" to the stud threads. After the threads have dried, apply Loctite® #277 and install the stud until it bottoms in the threaded hole in the mounting flange.



Caution:

Loctite® #277 must be shaken prior to application.



Caution:

Loctite® #277 may irritate sensitive skin. Refer to the product label for proper safety precautions.

2. 3. 4 Remove the discs (4) reaction springs (24) and reaction plate (23) from the mounting flange (1) sub-assembly, setting them aside on a clean dry surface.

2.4 Mounting and Assembly of the Brake

The following procedures require that the thickness of all discs (4) and friction discs (15) are in as-new condition. Prior to installation and shimming of the brakes, replace worn components, as required.



Warning:

Improper installation will result in inferior performance and possible brake failure.

2. 4. 1 Mount a magnetic base dial indicator on the motor housing, positioning the tip of the indicator on either the inside end (face) of the gear (brake end) or that of the coupling hub on the driving end of the motor.
2. 4. 2 Determine the total armature endplay by thrusting the motor shaft axially to the mechanical limits. Leave the shaft thrust out (towards the brake end of the motor) and record the total thrust clearance. This value will be used later in the set-up procedures.

Note: If armature endplay is beyond manufacturers maximum specification of 11/64", repairs may be required. Consult the motor manufacturer for corrective procedures.

**Warning:**

Bearing clearances in excess of manufacturer's maximum specification of 11164" may result in premature wear or damage to the brake components.

**Caution:**

Excessive jacking or prying when checking armature endplay may result in damage to bearings, bearing cartridges, or related components.

- 2. 4. 3 Attach the split front plate (93) to the motor side of the gear (22) with four hex head screws (99) and lockwashers (100), noting the orientation of the keyway slots and the step in the plate. See Figure 2. Do not tighten the screws at this time.
- 2. 4. 4 On 822 Frame motors, slide the spacer plate (94) onto the gear, attaching it to the front plate with hex head screws (99) and lockwashers (100). Tighten the screws to 44 ft.-lb., dry.
- 2. 4. 5 Position the two spacer plates (95) on the front plate (93), (or spacer plate (94) on 822 Frame motors). Apply Loctite® #242 (blue), or equivalent, to the threads of the hex head screws (103). Install and torque the screws to 75 lb.-in. Tighten the screws (99) attaching the front plate to the gear to 44 ft.-lb., dry. See Figure 2.
- 2. 4. 6 Assemble the mounting flange (1) to the motor with four 1-1/2-6NC x 5.00" Grade 8 hex head screws (use 4.00" long screws for 822 frame applications) and lockwashers (customer provided). If necessary, shim the mounting flange to correct for soft foot or perpendicularity (angular alignment) between the mounting flange and the motor shaft.

Note: For proper operation and service life, the DBA brake must be mounted concentrically and at right angles to the shaft. Concentricity of the shaft and brake should be held within .010" after final tightening of the mounting fasteners. Perpendicularity of the mounting flange (1) should be held within .014" TIR, referenced at the machined surface just outside the friction disc (ref. ∅: 29" diameter).

**Caution:**

Proper alignment is necessary to assure that the discs will track properly. Improper alignment will result in excessive wear to the friction discs (5), discs (4) and gear (22). See Figure 4.

- 2. 4. 7 Lubricate the gear teeth with a *LIGHT* coat of Molub-Alloy OG Heavy, or equivalent grease.

**Warning:**

Excessive grease application on the driving gear (22) may result in contamination of the friction material. Grease on the discs or the friction discs will significantly reduce the torque capacity of the brake and decrease its ability to hold the machinery in a safe position.

- 2. 4. 8 Slide one of the discs (4) onto the gear, with the spring pocket counterbores facing the motor and located approximately 45 degrees from the hex head screws (103) retaining the spacer plates (95).
- 2.4.9 Insert one spring (96) into each of the four spring pockets in the disc. Slide the disc towards the motor until the springs contact the spacer plate.
- 2. 4. 10 If not already installed, place a reaction spring (24) over every other clamp tube and slide the reaction plate (23) over the clamp tubes. Place the remaining reaction springs over the clamp tubes, positioned in-line with the reaction springs previously installed.

**Caution:**

Reaction plate springs (24) are to be assembled over every other stud (2). The springs on either side of the reaction plate must be assembled on the same stud. Improper assembly will result in cocking of the reaction plate and uneven brake release.

- 2. 4. 11 Install the two internally splined spacers (97) onto the gear and against the disc.
- 2. 4. 12 Noting the orientation of the spring pockets in Figure 2, insert the remaining four springs (96) in the remaining disc (4) and slide the disc onto the gear.

2.4.13 On 824 Motor frame applications, slide the spacer (102) onto the gear. See Figure 2.

2.4.14 Attach the end plate (98) to the gear using two 3/8-1 6NC2 x 1.75" screws, evenly spaced. Draw the end plate towards the gear to compress the springs using the two screws until they bottom in the tapped holes of the gear. Do not tighten the screws after they have bottomed in the holes.

! Caution:

Tightening these fasteners after they have bottomed may damage the threaded holes in the gear.

2.4.15 Install two hex head screws (99) with lockwashers (100) in the remaining two holes in the end plate. Tighten these two screws one turn at a time, in an alternating sequence, until the end plate contacts the end of the gear.

2.4.16 Remove the two 3/8-1 6NC2 x 1.75" screws, replacing them with hex head screws (99) and lockwashers (100). Tighten all four screws to 44 ft.-lb., dry.

2.4.17 Lubricate the exposed threads on the ends of the studs with 30 wt. oil or Never-Seez®.

2.4.18 Noting the position of the air inlets, hoist the end plate, spring housing and pressure plate assembly into position and slide it over the clamp tubes, placing two wear spacers (25) onto each stud between the pressure plate and spring housing. See Figure 6. The wear spacers will not pass through the holes in the pressure plate.

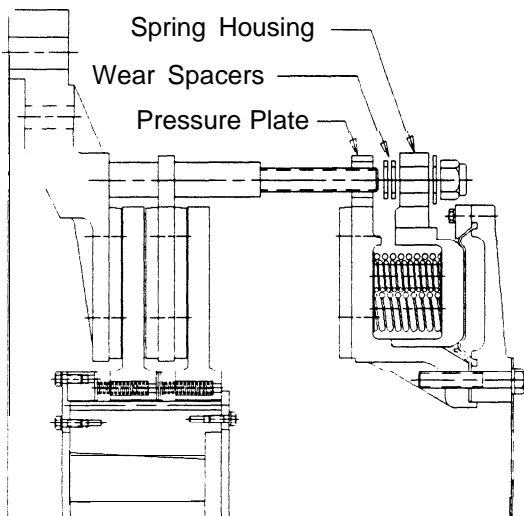

Fig. 6

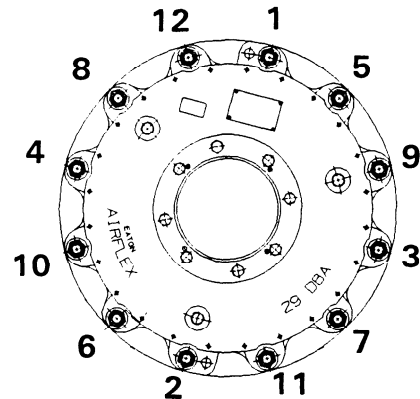

Fig.7

2.4.19 Assemble the washers (44) and locknuts (9) onto the studs. While supporting the weight of the pressure plate, spring housing and end plate assembly, tighten the locknuts ONE TURN AT A TIME and in a crosswise pattern, until the spring housing is seated against the clamp tubes. Torque the locknuts using the sequence shown in Figure 7 to 500 ft.-lb., lubed.

! Caution:

Failure to properly support the weight of the pressure plate sub-assembly while tightening the locknuts may result in binding of the reaction plate when the brake is disengaged, due to deflection of the studs.

! Caution:

The locknuts must be tightened gradually to prevent damage to the brake components.

2.4.20 Prior to putting the brake into service, disc centering set-up is required. Adjust the brake per Section 2.6 after installation of the air supply.

! Warning:

Failure to adjust the brake properly may cause premature wear of the brake components. Excessive heat may be generated from improper adjustment, resulting in damage to the brake and possible loss of torque.

2.5 Air Supply and Control System

Warning:

Maximum allowable air pressure is 120 psig (8.2 bar). Operation of the 229DBA at pressures exceeding 120psig may result in damage to the brake components.

Caution:

Minimum releasing pressure is 1 00psig (6.8 bar). Operation at pressures below minimum will result in brake drag and excessive heat and wear.

Brake response is dependent upon a good air system arrangement. Following are some general guidelines for installing the air control components.

- 2. 5. 1 229 DBA brakes have three 1" 11-1/2NPT ports in the end plate. It is recommended that all three ports be used, connected with air bridge piping.
- 2. 5. 2 Use full size piping consistent with the air inlets. Pneumatic piping should be free of foreign material such as pipe thread sealer, metal chips, etc.
- 2. 5. 3 Pipe length should be kept to a minimum. Excessive piping, pipe elbows, and other restrictions will slow down the response time of the brake.
- 2. 5. 4 The final connection to the brake air bridge piping must be made with a flexible hose.
- 2. 4. 5 Use poppet type solenoid valves and locate as close as possible to the brake. Spool type valves are not recommended.
- 2. 5. 6 The DBA brake does not require lubricated air; however the solenoid valve may. Consult the valve manufacturer.
- 2. 5. 7 Use of an in-line air filter is recommended to help prevent excessive moisture and contamination from entering the solenoid valve and brake.
- 2. 5. 8 Filters and regulators should be located prior to the solenoid valve, to ensure proper brake response.
- 2. 5. 9 A pressure switch should be located in the air supply line to the brake and interlocked with the equipment electrical controls. Locate the pressure switch as close as possible to the brake. Adjust the switch to 1 00psi, falling.
- 2. 5. 10 Installation of limit switches or proximity sensors may be desired to detect full mechanical release of the brake prior to operation of the machinery.

Warning:

Locating filters or regulators between the brake and solenoid valve may result in inadequate brake response.

Caution:

Pressure switches located too far from the brake may not detect air leakage near or within the brake assembly.

2.6 Brake Shimming Procedure

The following shimming procedures are required after initial installation of new brakes, per section 2.4.

Warning:

Improper installation will result in inferior performance and possible brake failure.

The procedures described in this section should be strictly adhered to for proper adjustment of the running clearances between the discs (4) and friction discs (5).

Caution:

Failure to properly shim the brake after installation may result in premature brake wear.

- 2. 6. 1 Ensure that angular alignment, as described in 2.1.2 has been checked and corrected, as necessary.

Table 1 - Gap Calculation	
Description	Result
Outer nominal clearance	0.250"
Total armature endplay from 2.4.2	
Subtract total endplay from 0.250"	
Divide result by 2. This is the Final Outer Gap Value	

- 2.6.2 Calculate the **desired** gap value (outer disc to outer friction disc) by using Table 1.
- 2.6.3 Apply 100psi air pressure to fully release the brake.
- 2.6.4 Using a prying tool, adjust the position of the outer disc (4) to ensure that it is resting against the outer spacer plate (102) on the gear.

Note: It may be necessary to add an equal number of shims (101) at each of the four brake mounting points to create a gap between the outer disc and the outer friction disc. See Figure 8.

- 2.6.5 Measure the gap between the outer disc and friction disc which is mounted on the pressure plate. See Fig. 9. The motor shaft should be thrust out (towards the brake end) to its axial limit when determining this dimension.

! Caution:

Improper motor shaft location will result in improper shimming of the brake, and subsequent brake damage.

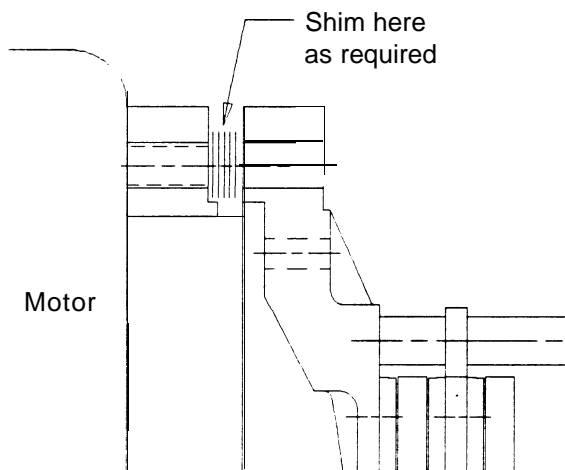

Fig. 8

- 2.6.6 Compare the gap measured in 2.6.5 to that calculated in Table 1. If necessary, add or remove an equal number of shims (101) at each of the four mounting points to adjust the gap to within +/- .010 of the value determined in Table 1.

- 2.6.7 Thrust the motor shaft axially to the mechanical limits while the brake is released. Observe the outer gaps between the discs (4) and adjoining friction disc (5) as the shaft reaches each limit. There **should be clearance at all times**. Leave the shaft thrust out (towards the brake end of the motor) and recheck the gap as in 2.6.5. Adjust per 2.6.6 if necessary.

Note: Lack of clearance between discs and friction discs indicates improper assembly, or excessively worn bearings or related components. Identify and correct prior to operating the machinery.

- 2.6.8 If necessary, shift the position of the brake to adjust the concentricity between the discs and friction discs.

- 2.6.9 Torque the 1-1/2"-6NC Grade 8 mounting fasteners to 800 ft.-lb., dry.

- 2.6.10 Exhaust the air pressure from the brake.

Note: During initial start up, monitor the axial travel of the discs between the mounting flange and the pressure plate. Due to various influences including gearing, couplings, or alignment of the motor to the pinion, the motor may drift axially. If the discs remain in constant contact with the friction material, shim adjustment of the brake or motor bearing repair may be required. The discs should rotate freely, with no contact to the friction material while the brakes are fully disengaged.

! Warning:

Failure to shim the brake properly may cause premature wear of the brake components. Excessive heat may be generated from improper shimming, resulting in damage to the brake and possible loss of torque.

! Caution:

Armature endplay in excess of manufacturers maximum specification of 11/64" may result in premature wear or damage to the brake components.

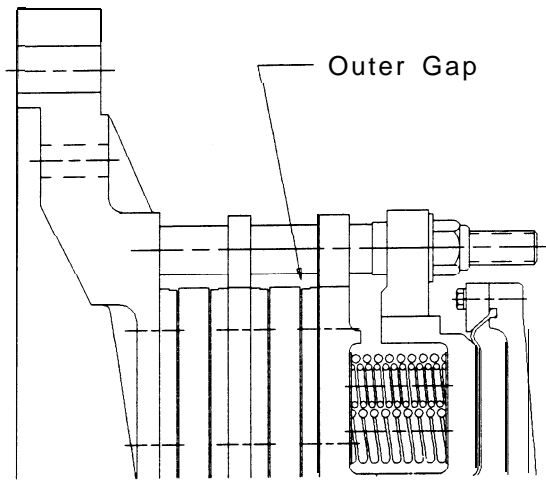

Fig. 9

3.0 OPERATION

3.1 Wear-in Procedures

- 3.1.1 The non-asbestos friction material used on DBA brakes may not develop rated torque, as a short wear-in period is required.



The non-asbestos friction material used on Airflex DBA brakes may not develop rated torque initially, as a short wear in period is required. Machine operation should therefore be monitored closely until the friction material wears in.

- 3.1.2 Burnishing of the friction material may be desired if full torque of the brake is required at initial start-up. Burnishing procedures are as follows:
- 3.1.2.1 Apply 55 psig air pressure (for 100 psig release brakes) to the brake to allow the brake to slip while the motor is running.
- 3.1.2.2 Run the motor at 100 RPM for approximately 1 1/2 to 2 1/2 minutes or until a moderate amount of smoke can be seen. **DO NOT ALLOW THE BRAKE TO SLIP FOR MORE THAN 2 1/2 MINUTES.**



Excessive slipping of the brake will result in damage to the brake components.

- 3.1.2.3 Apply full air pressure to completely disengage the brake. Smoke rising from the brake as it is released should be expected.
- 3.1.2.4 Allow the brake discs to cool to 120 - 150 degrees F. The use of fans or clean, dry compressed air can be used to accelerate the cooling process.



Use proper safety protection when using forced ventilation.

- 3.1.2.5 Repeat steps 3.1.2.1 thru 3.1.2.4 a minimum of two more times.
- 3.1.2.6 Allow the brake to completely cool to ambient temperature prior to testing the torque capacity of the brake or returning it to service.
- 3.1.3 During initial start up, monitor the axial travel of the discs between the mounting flange and the pressure plate. Due to various influences including gearing, couplings, or alignment of the motor to the pinion, the motor may drift axially. If the discs remain in constant contact with the friction material, shim adjustment of the brake or motor bearing repair may be required. The discs should rotate freely, with no contact to the friction material while the brakes are fully disengaged.



Failure to shim the brake properly may cause premature wear of the brake components. Excessive heat may be generated from improper shimming, resulting in damage to the brake and possible loss of torque.



Armature endplay in excess of manufacturers maximum specification of 11/64" may result in premature wear or damage to the brake components.

3.2 Periodic Inspection

- 3.2.1 A wear adjustment is required when the friction material is approximately one-quarter worn. Friction material must be replaced when worn to the step on the O.D. of the friction disc, or the brake has reached the **maximum wear** point. See the MAINTENANCE section for wear limits, wear adjustment and friction material replacement procedures.



Warning:
Failure to correct for brake wear at proper adjustment points will result in severe deterioration of brake torque.

- 3.2.2 Periodically observe the discs with the brake released. Dragging discs may be caused by broken springs, poor adjustment, excessive motor shaft float, or other excessively worn or damaged components. Repair or replace components as required.
- 3.2.3 Periodically check for air leakage of the diaphragm. For replacement, refer to 4.5.
- 3.2.4 Pneumatic and electrical control components and interlocks should be periodically checked for correct settings and operation.

4.0 Brake Maintenance



Danger:
Prior to performing any adjustment procedures on the DBA Brake, make sure that the machinery will remain in a secured position. Failure to do so could result in serious personal injury or possibly death.



Caution:
When replacing components, use only genuine **Airflex** replacement parts. Use of other materials may severely effect performance.



Caution:
Use only genuine **Airflex** friction material. Use of friction material not of **Airflex** origin may result in unpredictable brake performance and/or excessive wear of the brake components.

4.1 Wear Limits

- 4.1.1 Wear limits for DBA components are listed in Table 2. If any wear limit has been reached or exceeded, the component must be repaired or replaced.

Item	Item Description	Wear Description	Wear Limit
3	Clamp Tube	Maximum wear on O. D. Wear will be in the form of grooving from contact with the reaction plate or spring housing.	.030"
4	29 DBA Disc	Minimum thickness. Discs should be flat within .010"	.940"
4/22	Disc Splines / Gear	Maximum total backlash, measured at pitch diameter.	.070"
15	Friction Disc	Minimum thickness.	See Section 4.2.1 for Minimum gap "X" and wear step.
23	Reaction Plate	Maximum elongation of reaction holes.	.060"
19	Inner Spring	Minimum free height.	5.32"
20	Outer Spring		5.32"
24	Reaction Spring		2.37"

Table 3 - Wear Adjustment Positions						
Adjustment Position	Measured Gap "X"	Component:	Disc Centering Spacer Plates (95)(97)		Brake Wear Spacers (25)	
		Location: ①	A,B	C②	D	E
X ₀	Greater than 4.76"	Quantity:	2	0	2	0
X ₁	Less than or equal to 4.76"		1	1	1	1
X ₂	Less than or equal to 4.50"		0	2	0	2
Rebuild	Less than or equal to 4.24"		rebuild brake with new components and re-install per Section 2.0, INSTALLATION			

① See Figures 12 and 13 for spacer locations.
 ② Quantity of each spacer plate (95)(97) required at this location.

4.2 Wear Adjustment Procedure

- 4.2.1 Brake adjustment is required as the friction material wears. To determine when adjustment is required, measure the gap "X" between the pressure plate and the mounting flange with the brake engaged (air released), as shown on Figure 10. Compare the measured gap to the values listed in Table 3. Adjust the brake by re-arranging the wear spacers and spacer plates to the appropriate positions per the following procedures.

Note: Friction discs worn to or beyond the wear indicating step shown on Figure 11 must be replaced. If any of the friction discs are replaced, it is recommended that all four friction discs be replaced as a set, and the brake adjusted to the original position, as described in the INSTALLATION section.

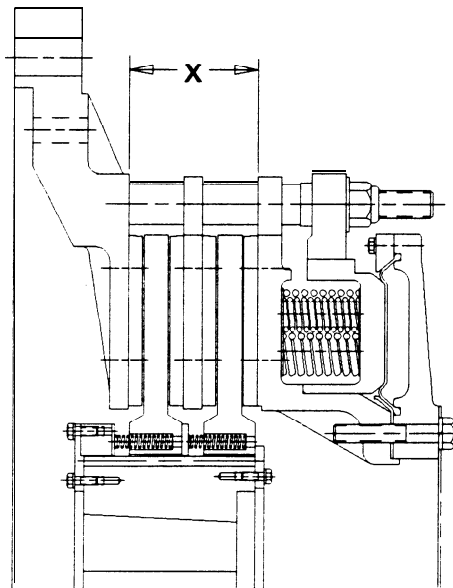

Fig. 10

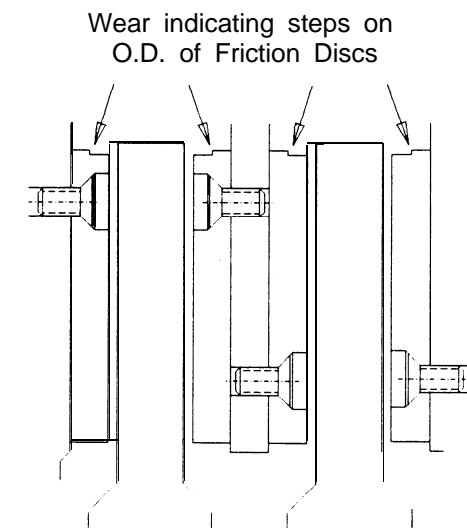

Fig. 11

Warning:

If wear adjustment is not made or brake is not taken out of service when wear limits have been reached, the brake torque may deteriorate to the point where the equipment will not stop properly.

Warning:

Premature adjustment of the brake may result in insufficient running clearances between the discs and the friction discs.

Caution:

Final brake wear limit may be reached prior to friction discs reaching the wear steps shown on Figure 11.

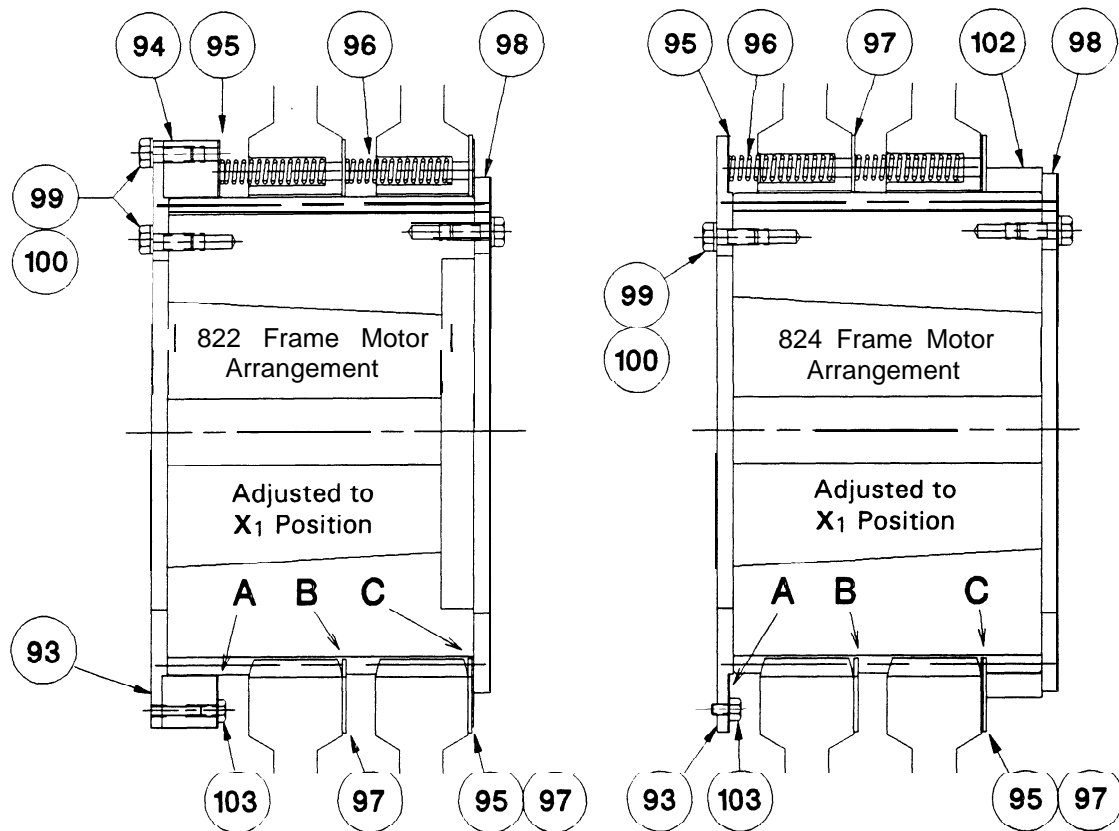

Fig. 12

- 4.2.2 Disconnect the air supply lines from the brake.
- 4.2.3 While supporting the spring housing, loosen the locknuts (9) ONE TURN AT A TIME and in an alternating (crosswise) pattern until the spring force is relieved. Remove the locknuts and flat washers (44).



Caution:
The locknuts must be loosened gradually to prevent damage to the brake components.

- 4.2.4 Slide the end plate, spring housing and pressure plate off of the studs as an assembly, removing the wear spacers (25). See Figure 6. Set the assembly aside on a clean, dry area, making sure not to damage the friction material wear surface on the pressure plate.

Note: If a stud (2) should happen to come loose, remove it completely and clean the threads in the mounting flange. Apply Loctite Loc-Quic Primer Grade "T" to the stud threads. After the threads have dried,

apply Loctite #277 and install the stud until it bottoms in the threaded hole in the mounting flange.



Caution:
Loctite #277 must be shaken prior to application.



Caution:
Loctite 8277 may irritate sensitive skin. Refer to the product label for proper safety precautions.

- 4.2.5 Remove two equally spaced hex head screws and lockwashers attaching the end plate (98) to the gear, replacing them with 3/8-1 6NC2 x 1.75" long screws.
- 4.2.6 Loosen the remaining screws and lockwashers attaching the end plate to the gear one turn at a time in an alternating sequence, until all of the spring force has been relieved.
- 4.2.7 Remove the remaining two screws along with the end plate.

42. 8 Remove the remaining components (discs, springs, spacers, and reaction plate) from the gear, noting the orientation and position of the discs.

4.2.9 Remove the hex head screws (103) attaching the spacer plates (95) to the front plate (93) (or spacer (94) on 822 frame motor applications).

4. 2. 10 Using the value obtained by measuring the gap "X" in 4.2.1, refer to Table 3 and Figure 12 and determine the proper quantity and location of the spacer plates. Install the remaining spacer plate (95) - if applicable - against the front plate (93) (or spacer (94) in 822 motor frame arrangements). See position "A" on Figure 12. Apply **Loctite® #242** to the threads of the screws (103) and reinstall in the front plate or spacer. Torque the screws to 75 lb.-in.

Note: After adjustment, if no spacer plates remain at this location, the screws should be reinstalled as described for later re-use.

4. 2. 1 1 Clean the gear, removing any contamination or old grease. Lubricate the gear teeth with a *LIGHT* coat of Molub-Alloy OG Heavy, or equivalent grease.



Warning:

Excessive grease application on the driving gear may result in contamination of the friction material. Grease on the discs or the friction discs will significantly reduce the torque capacity of the brake and decrease its ability to hold the machinery in a safe position.

4. 2. 12 Noting the position from which it was removed, align the disc so that the spring pockets are not in line with the hex head screws (103) and slide the first disc onto the gear. Insert the springs into the spring pockets in the disc and slide the disc towards the motor.

4. 2. 13 If not already installed, place a reaction spring (24) over every other clamp tube. Noting the orientation from which it was removed, slide the reaction plate over the clamp tubes, and against the disc. Install the remaining reaction springs over the clamp tubes, positioned in-line with the reaction springs previously installed.



Caution:

Reaction plate springs (24) are to be assembled over every other stud (2). The springs on either side of the reaction plate must be assembled on the same stud. Improper assembly will result in cocking of the reaction plate and uneven brake release.

4. 2. 14 Referring to Table 3, install the required number of spacer plates (97) onto the gear and against the disc - if applicable. See position "B" on Figure 12. The number of spacer plates (97) installed at the location described here should be equal to the number of spacer plates (95) that remain installed in 4.2.10.

4. 2. 15 Install the springs into the spring pockets in the second disc and slide the disc onto the gear.

4. 2. 16 Install the remaining spacer plates (95, 97) onto the gear. See position "C" on Figure 12. On 824 Frame motor applications, also install the spacer plate (102) onto the gear.

4. 2. 17 Attach the end plate to the gear using two **3/8-1 6NC2 x 1.75"** screws, evenly spaced. Draw the end plate towards the gear to compress the springs using the two screws until they bottom in the tapped holes of the gear. Do not tighten the screws after they have bottomed in the holes.



Warning:

Excessive tightening of these fasteners may damage the threaded holes in the gear.

4. 2. 18 Install two hex head screws (99) and lockwashers (100) in the remaining two holes in the end plate. Tighten these two screws one turn at a time, in an alternating sequence, until the end plate contacts the end of the gear.

4. 2. 19 Remove the two **3/8-1 6NC2 x 1.75"** screws, replacing them with hex head screws (99) and lockwashers (100). Tighten all four screws to 44 ft.-lb., dry.

4. 2. 20 Lubricate the threads on the ends of the studs (2) with 30 wt. oil or **Never-Seez®**.

- 4. 2. 21 Hoist the pressure plate, spring housing and end plate assembly into position, and slide the assembly over the clamp tubes, placing the required number of wear spacers (25) onto the studs between the pressure plate and spring housing (position "D" on Figure 13). See Table 3 for proper quantity.
- 4. 2. 22 Install the washers (44), remaining wear spacers (25), and locknuts (9) removed in 4.2.4. The wear spacers are stored under the locknuts (position "E") for re-use after replacing the friction discs. See Figure 13.
- 4. 2. 23 While supporting the weight of the pressure plate, spring housing and end plate assembly, tighten the locknuts ONE TURN AT A TIME and in a crosswise pattern, until the spring housing is seated against the clamp tubes. Torque the locknuts to 500 ft.lb., lubed. See Figure 7.



Caution:
The locknuts must be tightened gradually to prevent damage to the brake components.

- 4. 2. 24 Upon returning the brake to service, monitor the operation and clearances of the brake, as in 2.6.10. Adjust if required per the procedures in 2.6.

4.3 Friction Disc Replacement



Caution:
Use only genuine Airflex friction material. Use of friction material not of Airflex origin may result in unpredictable brake performance and/or excessive wear of the brake components.

Friction disc replacement is required when wear gap "X" has reached the minimum allowable gap of 4.24". Friction discs should also be replaced if the friction material has worn to the wear indicating step shown on Figure 11, or oil or grease have contaminated the surface. To ensure proper brake operation, it is recommended that friction discs be replaced as a set, if any require replacement.

- 4. 3. 1 Disconnect the air supply lines from the brake.

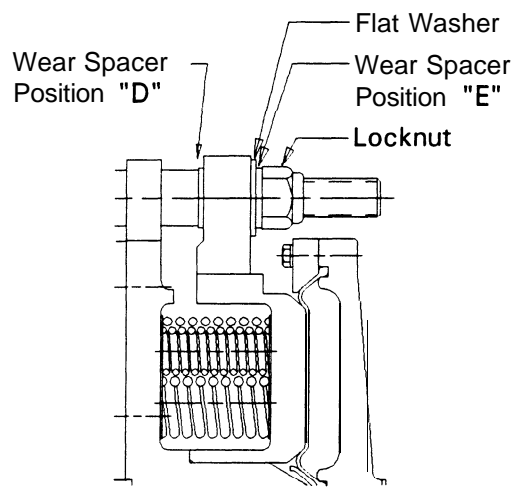

Fig. 13

- 4. 3. 2 Disassemble the brake components from the motor, as described in Sections 4.2.3 through 4.2.9. Remove the remaining disc from the gear, and remove the mounting flange from the motor, noting the quantity and location of shims between the mounting flange and motor frame.
- 4.3.3 Remove the old friction discs (5) from the pressure plate, reaction plate and mounting flange. Check the iron surfaces for burrs, and smooth with a course stone, if necessary. Remove any Loctite® residue from the threaded holes and clean the mounting surfaces.
- 4.3.4 Position the new friction discs on the mating component. Apply Loctite #262 to the threads of screws (6), install and torque the screws to 20 ft.-lb., following a crosswise tightening sequence.



Caution:
Before installing screws, make sure that the screw threads and threaded holes are clean to ensure that the new screws will lock properly.



Caution:
Loctite #262 must be shaken prior to application.



Caution:
Loctite #262 may irritate sensitive skin. Refer to the product label for proper safety precautions.

- 4.3.5 After replacement of friction discs, the procedures described in the Installation and Start-Up sections of this manual should be followed for re-assembly onto the motor.

4.4 Spring Replacement

- 4.4.1 While supporting the spring housing, loosen the locknuts (9) ONE TURN AT A TIME and in an alternating (crosswise) pattern until the spring force is relieved. Remove the locknuts, wear spacers (25) and washers (44).

Note: Wear spacers may be in the original or adjusted position. Make a note of the wear spacer location, so they may be reassembled in the proper position.



Caution:

The locknuts must be loosened gradually to prevent damage to the brake components.

- 4.4.2 Remove the end plate (12), spring housing (8), and the pressure plate (7) as an assembly and place it on a clean working surface with the end plate (12) facing up.
- 4.4.3 Match mark the pressure plate, spring housing and end plate to one another.
- 4.4.4 Remove the hex head screws (16) and lockwashers (17) in a crosswise sequence, ONE TURN AT A TIME. With these removed, the end plate (12), diaphragm (11) and attached components can be removed as an assembly.



Warning:

These screws must be loosened gradually and evenly.

- 4.4.5 Remove the spring housing (8), exposing the springs (19) and (20) and spring retainer plates (18).



Caution:

Before removing the old springs, make note of the number used and the position that they are in so that the new springs may be installed similarly for proper brake functioning.

- 4.4.6 Noting their orientation, remove the spring retainer plates (18), exposing the springs.
- 4.4.7 Remove the springs and check the free height. If the free height of any spring is less than the value shown on Table 2, the entire complement of springs must be replaced.
- 4.4.8 Clean the rubbing surfaces between the spring housing (8) and the pressure plate (7) and the spring housing and the diaphragm (11) and coat with Amsoil® long life, multi-purpose, moly-compound synthetic grease.
- 4.4.9 Place springs (19) and (20) on the bosses of the spring retainer plates that remain in the pressure plate.

Note: Retainer plates overlap one another in pairs, so that five bosses remain in each spring pocket.



Caution:

No spring retainer plates (18) should cross over the ribs in the pressure plate or spring housing (8).

- 4.4.10 Arrange the remaining spring retainer plates onto the springs so that they correspond with the retainer plates in the pressure plate.
- 4.4.11 Align the match marks and carefully lower the spring housing (8) over the pressure plate.
- 4.4.12 Align the match marks and place the end plate/diaphragm assembly in position.
- 4.4.13 Lubricate the threads of the hex head screws (16) with 30 wt. oil or Never Seez® and install, making sure the lockwashers (17) are in place. Tighten the screws one turn at a time using a crosswise pattern. Torque the screws to 150 ft.-lb., lubed.



Warning:

These screws must be tightened gradually and evenly.

- 4.4.14 Noting the position of the air inlets, hoist the end plate, spring housing and pressure plate assembly into position and slide it over the clamp tubes, placing the wear spacers (25) onto the studs in the appropriate position, as noted in 4.4.1.
- 4.4.15 Lubricate stud threads with 30 wt. oil or Never Seez®. Assemble the washers (44) and locknuts (9) onto the studs. While supporting the weight of the pressure plate, spring housing and end plate assembly, tighten the locknuts ONE TURN AT A TIME and in a crosswise pattern, until the spring housing is seated against the clamp tubes. Torque the locknuts using the sequence shown on Figure 7 to 500 ft.-lbs.



Caution:

The locknuts must be tightened gradually to prevent damage to the brake components.

4.5 Diaphragm Replacement

The end plate/diaphragm assembly can be removed without removal or disassembly of the spring housing and pressure plate, provided the locknuts (9) remain secured.



Caution:

Throughout the following procedures, do not loosen the locknuts (9). If spring housing/pressure plate disassembly is desired, refer to section 4.5.

- 4.5.1 While supporting the end plate, remove the hex head screws (16) and lockwashers.
- 4.5.2 Remove the end plate/diaphragm assembly. Place it on a clean working surface with the diaphragm facing up.
- 4.5.3 Remove hex head screws (21) and lockwashers (15) and outer clamp ring segments (10).
- 4.5.4 Remove the hex head screws (14), lockwashers (15) and inner clamp ring (13).
- 4.5.5 Remove the diaphragm (11) and clean the end plate and clamp rings, smoothing any nicks or burrs.
- 4.5.6 Install the new diaphragm on the end plate,

making sure the beaded edges of the diaphragm are seated properly in the grooves.

- 4.5.7 Position the outer clamp ring segments on the end plate.
- 4.5.8 Apply Loctite® #242 to the threads of the hex head screws (21). Attach the clamp ring segments with the screws and washers (92), and torque to 20 ft.-lb.
- 4.5.9 Attach the inner clamp ring (13) with hex head screws (14) and lockwashers (15). Torque the hex head screws to 20 ft.-lb., dry.
- 4.5.10 Clean the rubbing surfaces between the spring housing (8) and the diaphragm (11) and coat with Amsoil® long life, multi-purpose moly-compound synthetic grease.
- 4.5.11 Position the end plate assembly on the pressure plate. Align the match marks, making sure that the heads of the hex head screws (14) will fit into the corresponding counterbores in the pressure plate.
- 4.5.12 Assemble the end plate to the pressure plate with hex head screws (16) and lockwashers (17). Using a crosswise sequence, torque the screws to 150 ft.-lb., lubed.

5.0 ORDERING INFORMATION/ TECHNICAL ASSISTANCE

5.1 Equipment Reference

- 5.1.1 The brakes described in this manual contain some components that are non-standard. When ordering replacement parts, be sure to note the number on the product nameplate. Include any information regarding modification, conversion, or discrepancies of the brake and disc centering components from those described in this manual.
- 5.1.2 In any correspondence regarding Airflex equipment, refer to the information on the product nameplate and call or write:

Eaton Corporation
 Airflex Division
 9919 Clinton Road
 Cleveland, Ohio 44144
 Tel.: (216) 281-2211
 Fax: (216)281-3890

EATON PRODUCT WARRANTY

Subject to the conditions stated herein, Eaton Corporation warrants to the Purchaser that each new Airflex Product manufactured by Eaton will be free from failures caused by defects in material and workmanship, and will deliver its rated capacity, for a period of twelve (12) months from the date of shipment to Purchaser, provided such Product is properly installed, properly maintained, operated under normal conditions and with competent supervision. Warranty claims shall be made in writing and the part or parts shall, if requested by Airflex Division, be returned prepaid to the Airflex Division for inspection. Upon a determination that a defect exists, Eaton shall thereupon correct any defect, at its option either by repairing any defective part or parts or by making available at Eaton's plant a repaired or replacement part. This warranty does not extend to normal wear parts or components of the Product, such as friction material and friction surfaces.

LIMITATION OF WARRANTY

THE FOREGOING WARRANTY IS EXCLUSIVE AND IN LIEU OF ALL OTHER WARRANTIES WHETHER WRITTEN, ORAL OR IMPLIED. ANY IMPLIED WARRANTY OF MERCHANTABILITY OR FITNESS FOR A PARTICULAR PURPOSE ARE SPECIFICALLY EXCLUDED.

In no event shall Eaton be liable for special, incidental or consequential damages. Eaton's liability arising out of the supplying of such Product, or its use, whether in warranty, contract or otherwise, shall in no case exceed the cost of correcting defects in the Products as herein provided. Upon expiration of the twelve (12) month period, all such liability shall terminate. THE FOREGOING SHALL CONSTITUTE THE SOLE REMEDY OF PURCHASER AND THE SOLE LIABILITY OF EATON.